

## **DOUBLE AND TRIPLE LANGMUIR PROBES MEASUREMENTS IN INDUCTIVELY COUPLED NITROGEN PLASMA**

**M. Y. Naz and A. Ghaffar**

Department of Physics  
University of Agriculture Faisalabad, Pakistan

**N. U. Rehman**

Department of Physics  
COMSTS Institute of Information Technology, Islamabad, Pakistan

**S. Naseer**

Departments of Physics  
University of Peshawar, Peshawar 25120, Pakistan

**M. Zakaullah**

Departments of Physics  
Quaid-I-Azam University, Islamabad 45320, Pakistan

**Abstract**—The double and triple Langmuir probe diagnostic systems with their necessary driving circuits are developed successfully for the characterization of laboratory built low pressure inductively coupled nitrogen plasma, generated by 13.56 MHz radio frequency (RF) power supply along with an automatic impedance matching network. Using the DC properties of these two probes, the discharge plasma parameters like ion saturation current ( $I_{io}$ ), electron temperature ( $kT_e$ ) and electron number density ( $n_e$ ) are measured at the input RF power ranging from 250 to 400 W and filling gas pressures ranging from 0.3 to 0.6 mbar. An increasing trend is observed in  $kT_e$  and  $n_e$  with the increase of input RF power at a fixed filling gas pressure of 0.3 mbar, while a decreasing trend is observed in  $kT_e$  and  $n_e$  with the increase of filling gas pressure at a fixed input RF power of 250 W.

---

*Received 3 November 2010, Accepted 21 February 2011, Scheduled 22 February 2011*  
Corresponding author: M. Yasin Naz (yasin603@yahoo.com).

## 1. INTRODUCTION

Low pressure discharge plasmas exhibit the non-local thermodynamic equilibrium (non-LTE) behavior due to the large mean free paths and small electron collision probabilities with the heavy plasma species (ions, atoms, molecules) which leads to a non-uniform energy exchange among all the types of plasma species [1]. In these types of plasmas, the electron temperature ( $kT_e$ ) is much higher than that the other plasma species because they are light in mass and show high mobility under the influence of externally applied fields. The non-LTE behavior of low pressure discharge plasmas is of great importance from industrial point of view because a number of physically and chemically [2] non-equilibrium conditions might be possible by changing the working gas, filling pressure, electrode configuration, externally imposed electromagnetic field structure and discharge plasma volume.

The low pressure discharge plasmas can be excited and sustained by different plasma sources [3] and one such type is inductively coupled plasma (ICP) [4] in which the plasma chemistry is mainly controlled by the electron energies and gas temperatures [1]. It shows that in ICPs, the role of electron temperature and electrons number density ( $n_e$ ) is much important to understand the phenomena of electron impact ionization and excitation processes [9]. In order to fully characterize the ICPs, lot of work has been done in the past and many efforts are under way for the measurement of plasma parameters like  $kT_e$ ,  $n_e$ , ion number density ( $n_i$ ), electron saturation current ( $I_{eo}$ ), ion saturation current ( $I_{io}$ ), plasma potential ( $V_s$ ) and electron energy distribution function (EEDF) in a very precise way [5].

Different tools and techniques [6] can be employed to characterize the discharge plasmas but multi-tip Langmuir probes are considered to be the most powerful and experimentally the simplest technique for plasma characterization over a wide range of plasma densities because they did not require the assumption that plasmas to be in local thermodynamic equilibrium. Irvin Langmuir was the first who measured the volt-ampere characteristics by inserting a single conducting wire into plasma and then using it, he determined the electron temperature and plasma density [7]. This simple device now a days commonly used in plasma measurements, called the single Langmuir probe (SLP). The SLPs have some major drawbacks which are difficult to overcome particularly when the reference electrode is absent or when the plasma potential is not well defined. Moreover, unless the probe area is sufficient small, it may draw large electronic current by disturbing the discharge conditions when operated close to the space potential which shows that the single probe method is not

suitable for decaying plasmas accompanied by the perturbation of the discharge plasmas. In order to overcome these difficulties introduced by the SLP method, the double and triple Langmuir probe methods are developed which have negligible influence on the discharges and yield an accurate data for the measurement of plasma parameters in all types of discharge plasmas [8].

A similar effort has been done in this experiment to find out a consistent relationship between the discharge plasma parameters such as  $kT_e$ ,  $n_e$  [9],  $(I_{io})$  and the input parameters such as RF power (W), filling gas pressure (mbar) and gas flow rate in an inductively coupled nitrogen plasma with the help of locally manufactured and manually operated double and triple Langmuir probe methods [10, 24] along with their necessary driving circuits. Then a comparison is done between the results obtained by the double and triple Langmuir probes which show a good agreement in all measurements and verify the validity of this diagnostics technique.

## 2. EVALUATION OF PLASMA PARAMETERS

### 2.1. Double Probe Method

A double probe method (DPM) consists of two SLPs similar in shape with their exposed tips far enough from each other that the plasma sheaths of the individual probes did not overlap but not so far that the probes sample the different regions of the plasma. The probes are kept isolated from the ground and connected across a variable biasing voltage source ( $V_d$ ) with an associated current ( $i_d$ ) through the probe circuit as shown in the Figure 1.

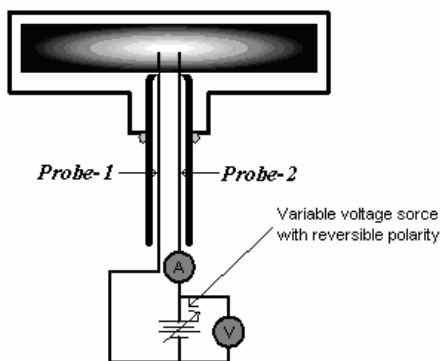

**Figure 1.** The schematic diagram of double Langmuir probe method.

When the electrons in the plasma obey the Maxwellian distribution [9], the plasma parameters can be determined from the  $I$ - $V$  characteristics of the probe as follow [7, 10]:

According to the Kirchoff's current law, at any instant the total current through the probe circuit is the sum of the currents through the probe-1 and probe-2:

$$\sum I_p = I_{p1} + I_{p2} = 0 \quad (1)$$

Then

$$\begin{aligned} I_{io} + I_{eo} \exp\left(-\frac{eV_1}{kT_e}\right) + I_{io} + I_{eo} \exp\left(-\frac{eV_2}{kT_e}\right) &= 0 \\ \left(1 - \exp\left(-\frac{eV_1}{kT_e}\right)\right) + \left(1 - \exp\left(-\frac{eV_2}{kT_e}\right)\right) &= 0 \quad -I_{io} = I_{eo} \end{aligned} \quad (2)$$

Now the current  $I$  in the loop can be written as:

$$\begin{aligned} I &= I_{p1} = I_{p2} \\ I &= I_{io} \left(1 - \exp\left(-\frac{eV_1}{kT_e}\right)\right) = I_{io} \left(1 - \exp\left(-\frac{eV_2}{kT_e}\right)\right) \quad \because -I_{io} = I_{eo} \end{aligned} \quad (3)$$

Since

$$\tanh x = \frac{e^{2x} - 1}{e^{2x} + 1}$$

Then Equation (3) will become as:

$$I = I_{io} \tanh\left(-\frac{eV_d}{2kT_e}\right); \quad \text{where } V_d = V_2 - V_1 \quad (4)$$

Differentiating Equation (4) with respect to  $V_d$  we get:

$$\left(\frac{dI}{dV_d}\right)_{V_d=0} = \frac{eI_{io}}{2kT_e} \quad (5)$$

The slope of the  $I$ - $V$  characteristics at zero relative bias voltage  $V_d$  provides  $kT_e$ . The electron number density can be determined from the ion saturation current and electron temperature by using the following equation:

$$I_{io} = 0.61n_e eA \sqrt{\frac{kT_e}{m_i}} \quad (6)$$

## 2.2. Triple Probe Method

Although the single and double Langmuir probe are very good tools for the plasma characterization but they require the voltage sweep

to obtain the  $I$ - $V$  characteristics which limits the time resolution of the measurements and makes them difficult to characterize the time varying plasmas. This problem can be solved by using a triple Langmuir probe method (TPM) [8] consisting of three metallic tips exposed to the same plasma conditions as shown in the Figure 3. The  $V_{d1-2}$  is the variable biasing voltage applied between the probe-1 and probe-2 and  $I_1$  is the corresponding change in probe current, while  $V_{d1-3}$  is the potential difference between the probe-1 and the floating probe-3. The accurate measurement of the  $kT_e$  requires the condition that  $V_{d1-2} \geq 2kT_e$ . During this experiment it is assumed that the space potential  $V_s$  is uniform in the sampling region and the potential difference of all three probes from  $V_s$  is shown in the Figure 2.

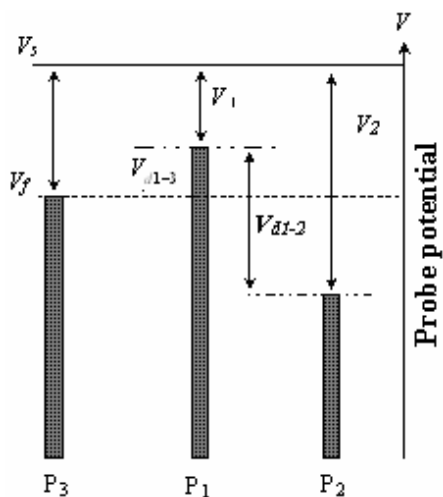

**Figure 2.** Potential of each probe with respect to  $V_s$ .

As the current though each probe can be written as:

$$I_{p1} = I_1 = I_{io} + I_{eo} \exp\left(-\frac{eV_1}{kT_e}\right) \tag{7}$$

$$I_{p2} = I_2 = I_{io} + I_{eo} \exp\left(-\frac{eV_2}{kT_e}\right) \tag{8}$$

$$I_{p3} = 0 = I_{io} + I_{eo} \exp\left(-\frac{eV_3}{kT_e}\right) \tag{9}$$

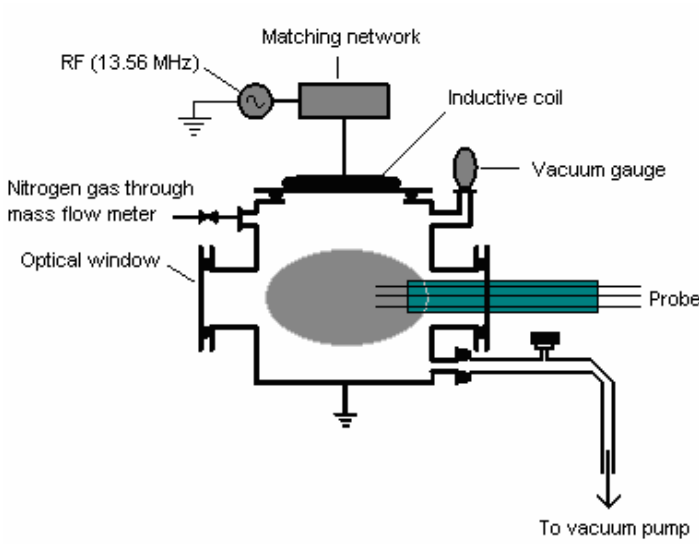

**Figure 3.** A schematic diagram of experimental setup used for generation and characterization of inductively coupled nitrogen plasma.

Dividing Equation (7) by Equation (8) we get.

$$-1 = \frac{1 - \exp\left(-\frac{eV_1}{kT_e}\right)}{1 - \exp\left(-\frac{eV_2}{kT_e}\right)} \quad \therefore -I_{io} = I_{eo}$$

$$\exp\left(-\frac{eV_1}{kT_e}\right) \left(\exp\left(\frac{eV_1}{kT_e}\right) - 1\right) = \exp\left(-\frac{eV_2}{kT_e}\right) - 1$$

$$\left(\exp\left(\frac{eV_1}{kT_e}\right) - 1\right) = \exp\left(-\frac{e(V_2 - V_1)}{kT_e}\right) - \exp\left(\frac{eV_1}{kT_e}\right)$$

$$\left(\exp\left(-\frac{e(V_3 - V_1)}{kT_e}\right) - 1\right) = \exp\left(-\frac{e(V_2 - V_1)}{kT_e}\right) - \exp\left(-\frac{e(V_3 - V_1)}{kT_e}\right)$$

where

$$\exp\left(-\frac{eV_3}{kT_e}\right) = 1$$

$$2 \exp\left(-\frac{eV_{d1-3}}{kT_e}\right) = 1 + \exp\left(-\frac{eV_{d1-2}}{kT_e}\right) \quad (10)$$

In the limit  $eV_{d2} \gg 2kT_e$  the Equation (10) will become as:

$$kT_e = \frac{eV_{d1-3}}{\ln 2} = \frac{e(V_1 - V_f)}{\ln 2} \quad (11)$$

Electron temperature can be calculated by using above Equation (11). Obviously, it is not reasonable to ignore the term  $\exp(-V_{d1-2}/kT_e)$  of Equation (10) in the limit of  $eV_{d2} \gg 2kT_e$  without considering the value of the ratio  $V_{d1-2}/V_{d1-3}$ .

Now the  $n_e$  can be obtained from the Equation (6) [8]:

$$n_e = \frac{1}{0.61Ae\sqrt{\frac{kT_e}{m_i}}} I_{io} \quad (12)$$

where, in the case of triple Langmuir probe, the  $I_{io}$  can be obtained by subtracting the Equation (9) from the Equation (7) and simplifying:

$$I_{eo} = I_1 \frac{\exp\left(-\frac{eV_{d1-3}}{kT_e}\right)}{\left(1 - \exp\left(-\frac{eV_{d1-3}}{kT_e}\right)\right)} \quad (13)$$

Hence the Equation (12) will be modified as:

$$n_e = \frac{-I_1}{0.61Ae\sqrt{\frac{kT_e}{m_i}}} \frac{\exp\left(-\frac{eV_{d1-3}}{kT_e}\right)}{\left(1 - \exp\left(-\frac{eV_{d1-3}}{kT_e}\right)\right)} \quad \because -I_{io} = I_{eo} \quad (14)$$

This Equation (14) gives the electron number density in plasma with the triple Langmuir probe method.

### 3. EXPERIMENTAL SETUP

The schematic diagram of the experiment setup used for the generation and characterization of ICP is shown in the Figure 3. The nitrogen discharge plasma is generated by 13.56 MHz RF [9–11] generator having  $50 \Omega$  resistance, connected across a spiral planar coil shaped electrode of copper having 13 turns and 30 cm diameter placed at the top opening of a grounded cylindrical plasma chamber of stainless steel. The plasma chamber is 31 cm in diameter and 24 cm in height with four main vacuum tight multi role ports of 9.8 cm diameter each. The spiral planar coil is insulated from the chamber by a 1.2 cm thick quartz plate which not only serves as an insulator between the coil and plasma chamber but also helps in maintaining the vacuum inside the chamber. In order to keep the reflected power below 2% and to maximize the power transfer from the RF generator to discharge gas,

an automatic impedance matching network consisting of a tuning unit and a control unit is connected between 13.56 MHz RF generator and spiral planar coil [12, 13]. For the flow mode operation and generation of low pressure discharge plasma, a rotary vane pump is connected across the chamber which has the capability of lowering the pressure up to  $10^{-3}$  mbar. The pressure inside the chamber is monitored by a pirani gauge and the gas flow rate from the main cylinder to the plasma chamber is controlled by the mass flow meter. In this experiment the flow rate of nitrogen gas is kept constant at 50 sccm.

### 3.1. Development of the Double and Triple Langmuir Probes

The careful manufacturing and circuit arrangements for the multi-tip probes are very important for their successful operation. In order to verify that the probe dimensions chosen in this design are proper, the probe theory presented earlier should be applicable for the expected plasma parameters which require that the several conditions should meet which are stemmed from the approximations made in the derivation of probe theory. So keeping these in mind a compatible probe system is developed for the inductively coupled nitrogen plasma characterization as shown in the Figure 4. It consists of three exposed Nickel-Chrome wires of equal length and diameter aligned with the

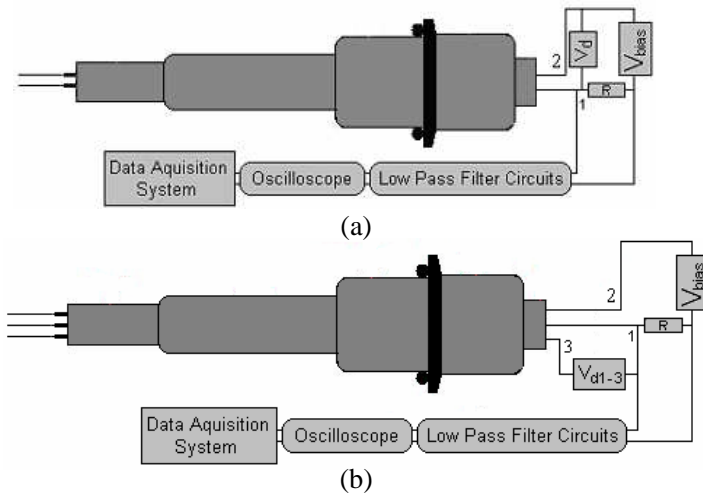

**Figure 4.** (a) The double Langmuir probe with its electrical circuit arrangement. (b) The triple Langmuir probe with its electrical circuit arrangement.



plasma flow. These wires are 0.22 mm in diameter, fed through a 17.5 cm long four bore ertalon tubing with an inner diameter of 6 mm. This vacuum tight ertalon tubing not only insulates the wires from the plasma chamber but also keeps the wires at a fixed separation and aligned with the gas flow. The 11 mm tip of each symmetric wire is exposed to plasma for the collection of charged particles and after passing the wires through ertalon tubing these are connected with the connector pins and insulated with the heat shrink capillary tubes. Then each of these pins is connected to the central connector of a BNC coaxial cable [14,15] which runs along the probe arm and down to an isolated BNC feed through to pass the signals out of the plasma chamber to the digital oscilloscope using the electrical circuit arrangements made for the double and triple Langmuir probes. In order to eliminate the RF noise picked up by the cables, the RC low pass filters [16–19] are used at each input of the oscilloscope. A dc power supply is used for manual scanning of the dc voltage difference applied across the probes from minimum value of  $-26\text{ V}$  to maximum value of  $+26\text{ V}$  and the corresponding change in current is measured across a  $47\text{ k}\Omega$  resistor. A single common ground is used for the entire setup.

### 3.2. Technical Data Table for Probe Designing

Probe material	Nickel-Chrome
Tip length	11 mm
Tip diameter	0.22 mm
Tip area	$7.59\text{ mm}^2$
Insulating material	Ertalon
Ertalon tubing diameter	6 mm
Ertalon tubing length	17.5 cm
DC supply	$+120\text{ V}$ to $-120\text{ V}$

## 4. EXPERIMENTAL MEASUREMENTS

For double Langmuir probe method, the  $kT_e$  and  $I_{i0}$  are obtained from the slope of the  $I$ - $V$  characteristics at zero relative bias voltage ( $V_d$ ) with the help of Equation (5) and then these values are used in the Equation (6) to obtain  $n_e$ . The  $I$ - $V$  characteristics of double Langmuir probe at 250 W input RF power [19, 20] and 0.3, 0.4, 0.5 and 0.6 mbar filling pressures are shown in the Figure 5(a). As the

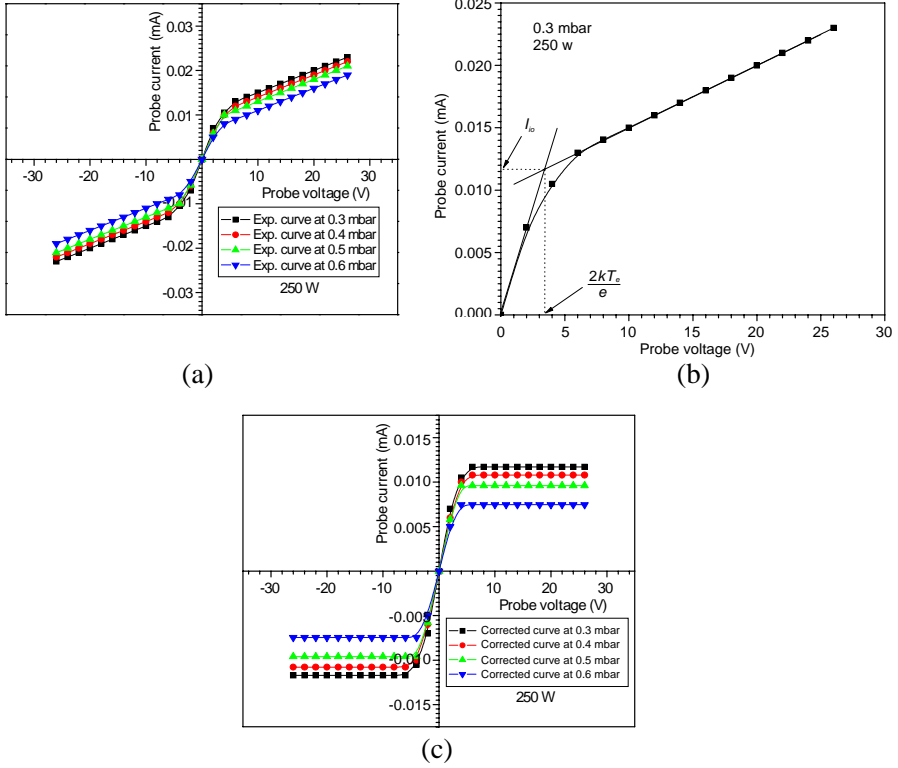

**Figure 5.** (a) The double probe  $I-V$  characteristics at 250 W RF power and 0.3, 0.4, 0.5 and 0.6 mbar filling pressure. (b) The slope of the  $+ve$  portion of double probe  $I-V$  characteristics at zero relative bias voltage  $V_d$ . (c) The corrected  $I-V$  characteristics at 250 W RF power and 0.3, 0.4, 0.5 and 0.6 mbar filling pressures.

currents from plasma to probes may be due to diffusion, convection, high energy electrons [19], ions and the electric field of sheath about the probes [21], which shows that for the accurate measurement of electron temperature and electron number density, the slope of the  $I-V$  characteristics must satisfy the Equation (5). For that a necessary correction in the  $I-V$  characteristics is done by fitting a straight line to the ion saturation current regimes shown in the Figure 5(b), whose intersection with the ordinate gives the ion saturation current and the resulting slope of these  $I-V$  characteristics satisfy the Equation (5). The corrected  $I-V$  characteristics for the double Langmuir probe method are shown in the Figure 5(c).

In triple Langmuir probe method, the electron temperature is

obtained using the Equation (11) under the same conditions of input RF power and filling pressure as provided to the double Langmuir probe method and then these values of electron temperature are used in Equation (14) to obtain the electron number density in the limit of  $eV_{d1-2} \gg 2kT_e$ . Where in Equation (11),  $V_{d1-3}$  is the voltage difference between the probe-1 and the floating probe-3. This voltage difference  $V_{d1-3}$  and the current  $I_1$  through the probe-1 are the functions of biasing voltage difference  $V_{d1-2}$  applied between the probe-1 and probe-2. By the limit  $eV_{d1-2} \gg 2kT_e$ , we mean that the probe currents in this experiment are saturated at maximum voltages of +4.1 V and -4.1 V and hence the plasma potential should be less than 4.1 V because the electrons in the plasma are moved from the plasma to the probes by the electric force of the applied saturation voltages.

### 5. RESULTS AND DISCUSSION

The graphical representation of the results obtained with the double and triple Langmuir probe methods for the electron temperature and electron number density as a function of input RF power and filling pressure is shown in the Figures 6 and 7.

From the results obtained so far with the double and triple Langmuir probe methods, it is observed that with the increase of input RF power from 250 to 400 W at a fixed pressure of 0.3 mbar, not only the electron temperature but the electron number density is

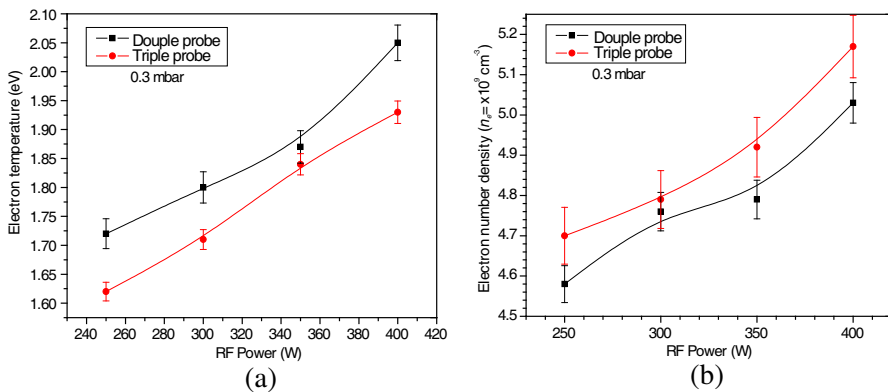
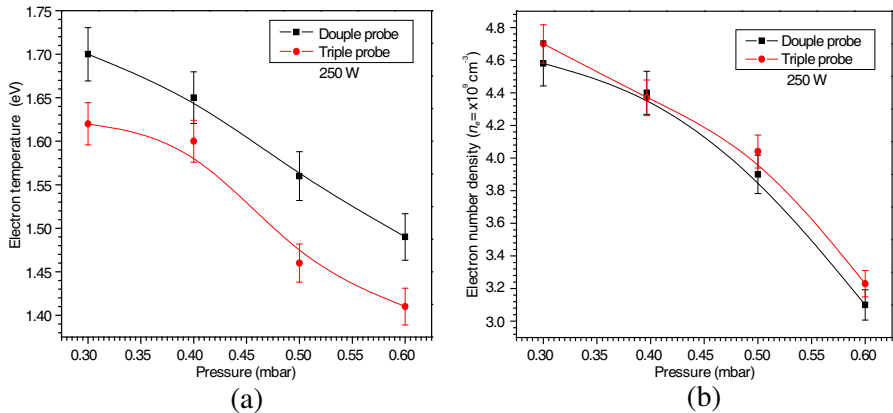

**Figure 6.** (a) The variational trend of electron temperature with double and triple Langmuir probe methods at 0.3 mbar filling pressure and different input RF powers. (b) The variational trend of electron number density with double and triple Langmuir probe methods at 0.3 mbar filling pressure and different input RF powers.

increased as well, shown in the Figure 6 [22]. This increase in electron temperature may be due to an increase in kinetic energy of electrons under the influence of increasing incident RF power. As for as the electron number density is concerned, although it reciprocally depends upon the electron temperature as mentioned in the probe theory but in our case, this increase in electron number density might be due to an increase in ionization events in the discharge plasma at higher powers, which results in an increase of the ion saturation current having the direct relation with the electron number density [22]. The reason behind the increase in ionization events is that the increasing input RF power provides more and more available energy to be transferred to the discharge plasma which results in large ionization probabilities especially at low filling pressures.

The variational trend in electron temperature and the electron number density at different filling pressures and constant input RF power of 250 W is also observed as shown in the Figure 7. It is observed that the electron temperature decreases with the increase of the filling pressure inside the plasma chamber. This decreasing trend in the electron temperature may be due to the following reasons: The increase in filling pressure inside the chamber brings about a high cooling frequency in the plasma chamber which causes a decrease in electron energy and consequently the electron temperature [22].

The filling pressure and input RF power dependence of the average electron energy  $\langle \varepsilon \rangle$  and hence the electron temperature can



**Figure 7.** (a) The variational trend of electron temperature with double and triple Langmuir probe methods at 250 W input RF power and different filling pressures. (b) The variational trend of electron number density with double and triple Langmuir probe methods at 250 W input RF power and different filling pressure.

also be explained by the steady state particle balance equation due to a linear relationship between the average electron energy and the effective electron temperature. When the filling pressure inside the chamber increases, the electron collision frequency with the plasma species also increases and the mean free path between the successive collisions decreases which shows that rather than gain of energy by the electrons, more and more energy transfer from electrons to the plasma species takes place and under this situation the balance between the total ionization events and the total particle losses to the chamber walls [23, 24] results in decrease of the electron temperature and an increase in the neutral gas temperature as we increase the filling pressure inside the chamber.

A similar decreasing trend with the increase of filling pressure at constant input RF power of 250 W is found in electron number density measured by the double and triple Langmuir probe methods. For the double Langmuir probe method these calculations are made in the low current portion of the  $I$ - $V$  characteristics to minimize the effect of radio frequency fluctuations. This decreasing trend in the electron number density may be due to the following reasons: The increase in filling pressure inside the plasma chamber causes a cooling affect in the discharge plasma which results in a decrease of the ion saturation current and consequently the electron number density [17]. At higher pressures and relatively low input powers, the elastic collisions of the electrons with the plasma species can also play a significant role in the reduction of the ionization events. Similarly at higher pressure, the high energy tail of the electron energy distribution function depletes to the low energies and the availability of the highly energetic electrons for the electron impact ionization processes decreases and consequently the electron number density. This depletion in the tail of the electron energy distribution function may be due to the rapid diffusion and recombination of the highly energetic electrons at the chamber walls [23].

Finally, it is observed that although the graphical representation of the results obtained by the double and triple Langmuir probe methods shows the similar variational trend but the electron temperature obtained by the double Langmuir probe method is relatively higher while the electron number density is relative lower than that obtained by the triple Langmuir probe method. It may be due to the following reasons: the double Langmuir probe operates close to the floating potential and measures only the high energy electrons in the tail of the electron energy distribution function. These highly energetic electrons have a little influence of the probe electric field at relatively small dc biasing voltages and cause an inaccuracy in the determination of

the slope of the  $I$ - $V$  characteristics in the retardation region. This inaccuracy in slope determination normally can range from 10% to 25%. In order to overcome this problem a highly sensitive driving circuit is required by the double Langmuir probe method for the voltage sweep to obtain the  $I$ - $V$  characteristics which makes the probe system not only more complicated and susceptible to the disturbances in the plasma but also causes the grounding problem. Moreover, there could be asymmetry in the probe tips and any of the tips can have the dimensions smaller or larger than the others, causing a shift in  $I$ - $V$  characteristics and consequently in measurements.

## 6. CONCLUSIONS

The double and triple Langmuir probes are developed successfully along with their necessary driving circuits to characterize the low pressure inductively coupled nitrogen plasma and their results are compared to check the validity of these methods. First the electron temperature and the electron number density is measured by these two methods at 0.3 mbar filling pressure and 250 to 400 W input RF power. It is observed that at a fixed pressure of 0.3 mbar, both the electron temperature and the electron number density are increased with the increase of the input RF power, and the relative inaccuracy in the measurements made with the double and triple Langmuir probe methods for the electron temperature ranges from 3% to 12% and for the electron number density ranges from 3% to 14%.

Similarly the behavior of the electron temperature and the electron number density is also checked at a fixed input RF power of 250 W and filling pressure ranging from 0.3 to 0.6 mbar and it is found that not only the electron temperature as expected is decreased with the increase in filling pressure but the electron number density also showed the same decreasing trend. The relative inaccuracy in the measurements made with the double and triple Langmuir probe methods for the electron temperature and the electron number density at 250 W RF power and 0.3 to 0.6 mbar filling pressure, shows that the electron temperature varies from 5% to 10% and the electron number density varies from 4% to 14% but overall trend in the measurements shows that the electron temperature measured with the double Langmuir probe method is some what higher and the electron number density is some what lower than that measured with the triple Langmuir probe method. The final outcomes of this experiment shows that the results obtained for the electron temperature and the electron number density by these two methods are very much consistent and a good agreement is found among the measurements which shows that

the multi-tip probes are good tools for the characterization of radio frequency generated discharge plasmas.

## REFERENCES

1. Grill, A., *Cold Plasma in Materials Fabrication*, IEEE Press, New York, 1993.
2. John, P. I., *Plasma Sciences and the Creation of Wealth*, Tata McGraw-Hill Publishing Company Limited, New Delhi, 2005.
3. Franklin, R. N., *Plasma Phenomena in Gas Discharges*, Oxford University Press, Oxford, 1977.
4. Moore, G. L., *Introduction to Inductively Coupled Plasma Atomic Emission Spectroscopy*, Vol. 3, Elsevier, New York, 1989.
5. Jain, R. and M. V. Kartikeyan, "Design of a 60 GHz, 100 kW CW gyrotron for plasma diagnostics: GDS-V.01 simulations," *Progress in Electromagnetics Research B*, Vol. 22, 379–399, 2010.
6. Yamaguchi, S., G. Sawa, and M. Ieda, "Variation of ion current flowing into double probes with coating of organic thin film in RF discharge plasma," *J. Appl. Phys.*, Vol. 26, No. 5, 728, 1987.
7. Chen, F. F., *Plasma Diagnostic Techniques*, Academic Press, New York, 1965.
8. Huddleston, R. H. and S. L. Leonard, *Plasma Diagnostic Technique*, Academic Press, New York, 1965.
9. Pandey, R. S., "Cold plasma injection on VLF wave mode for relativistic magnetoplasma with A.C. electric field," *Progress in Electromagnetics Research C*, Vol. 2, 217–232, 2008.
10. Manory, R. R., U. Carmi, R. Avni, and A. Grill, "A comparative study of silicon deposition from  $\text{SiCl}_4$  in cold plasma using argon,  $\text{H}_2$  or  $\text{Ar} + \text{H}_2$ ," *Thin Solid Films*, Vol. 156, 1988.
11. Sha, W. E. I. and W. C. Chew, "High frequency scattering by an impenetrable sphere," *Progress In Electromagnetics Research*, Vol. 97, 291–325, 2009.
12. Costa, E. M. M., "Parasitic capacitances on planar coil," *Journal of Electromagnetic Waves and Applications*, Vol. 23, No. 17–18, 2339–2350, 2009.
13. Wen, S. and L. Zhu, "Numerical synthesis design of coupled resonator filters," *Progress In Electromagnetics Research*, Vol. 92, 333–346, 2009.
14. Jian, L. and K. T. Chau, "Analytical calculation of magnetic field distribution in coaxial magnetic gears," *Progress In Electromagnetics Research*, Vol. 92, 1–16, 2009.

15. Shiri, A. and A. Shoulaie, "A new methodology for magnetic force calculations between planar spiral coils," *Progress In Electromagnetics Research*, Vol. 95, 39–57, 2009.
16. Wu, H. W. and R. Y. Yang, "Design of a triple-passband microstrip bandpass filter with compact size," *Journal of Electromagnetic Waves and Applications*, Vol. 24, No. 17–18, 2333–2341, 2010.
17. Yin, Q., L. S. Wu, L. Zhou, and W. Y. Yin, "Compact dual-band bandpass filter using asymmetrical dual stub-loaded open loops," *Journal of Electromagnetic Waves and Applications*, Vol. 24, No. 17–18, 2397–2406, 2010.
18. Xia, Q., Z. X. Tang, and B. Zhang, "A Ku-band push-push dielectric resonator oscillator," *Journal of Electromagnetic Waves and Applications*, Vol. 24, No. 14–15, 1859–1866, 2010.
19. Pandey, R. S., "Gradient effect on kelvin helmholtz instability in the presence of inhomogeneous d.c. electric field," *Progress In Electromagnetics Research B*, Vol. 11, 39–53, 2009.
20. Ibrahim, A., C. Dale, W. Tabbara, and J. Wiart, "Analysis of the temperature increase linked to the power induced by RF source," *Progress In Electromagnetics Research*, Vol. 52, 23–46, 2005.
21. Rossnagel, S. M., R. J. Cuomo, and W. D. Westwood, *Handbook of Plasma Processing Technology*, Noyes Publications, Park Ridge, N.J., 1910.
22. Yong-ik, S., H. B. Lim, and R. S. Houk, "Diagnostic studies of low-pressure inductively coupled plasma in argon using a double Langmuir probe," *J. Anal. At. Spectrom.*, Vol. 17, 565–569, 2002.
23. Pu, Y. K., Z. G. Guo, A. U. Rehman, and Z. D. Yu, "Tuning effect of inert gas mixing on electron energy distribution function in inductively coupled discharges," *Ma. J. Plasma Phys. and Control. Fusion*, Vol. 48, 2006.
24. Pandey, R. S. and D. K. Singh, "Study of electromagnetic ion-cyclotron instability in a magnetoplasma," *Progress In Electromagnetics Research M*, Vol. 14, 147–161, 2010.