

## CONTRIBUTION TO THE DEVELOPMENT OF FLAT FRESNEL REFLECTORS IN W BAND FOR NEW IMAGING APPLICATIONS

**Kaoutar Zeljami<sup>1</sup>, Juan Vassal'lo<sup>2</sup>, Antonio Tazon<sup>1</sup>, Tomas Fernandez<sup>1</sup>,\*, Angel Mediavilla<sup>1</sup>, and Angel Vegas<sup>1</sup>**

<sup>1</sup>Department of Communications Engineering, University of Cantabria, Edificio Ingeniería de Telecomunicación-Professor Jose Luis Garcia, Plaza de la Ciencia S/N, Santander 39005, Spain

<sup>2</sup>CSIC — Institute of Security of the Information, Antennas Technology Laboratory, Serrano 144, Madrid 28006, Spain

**Abstract**—This work presents an experimental study in W band about the behavior of a plane Fresnel reflector when the feeder changes its position on the surface of a sphere whose centre is the same of the Fresnel plate zones. For this purpose, an experimental system based on seven Fresnel plate zones and two different levels has been developed. The center frequency of the reflector is 96 GHz, the focal length is 100 mm and height between levels is 0.78 mm. Based on this Fresnel reflector, an experimental set up has been developed. The horn antenna feeder is fixed and situated in far field and the receiver is also a horn antenna located at the Fresnel focal distance. Both the reflector and the receiving antenna have some rotation capability to enable measurements from different angles. The experimental results show a good, stable behavior in gain versus the angular position of the feeder. This special property of Fresnel reflectors is impossible in parabolic reflectors and consequently, Fresnel reflectors could be used in new applications as radar imaging, increasing the radar field of view or improving the resolution by means of several squint feeders working simultaneously on the same lens or reflector. Therefore, the main objective of this paper is to analyze the behavior of this experimental set up for developing new Fresnel reflector-based applications.

---

*Received 27 June 2013, Accepted 30 July 2013, Scheduled 16 August 2013*

\* Corresponding author: Tomas Fernandez (tomas.fernandez@unican.es).

## 1. INTRODUCTION

As is well known, the use of reflectors or lenses based on diffractive Fresnel zones introduces a loss of gain and bandwidth when compared with parabolic reflectors. These drawbacks provoke manufacturer rejection any antenna design using this concept. Therefore, the only possibility to introduce Fresnel diffraction into the microwave reflector antenna market is to study other kinds of applications where parabolic reflectors can not be competitive.

As is also well known, flat reflectors based on the Fresnel diffraction concept have the following characteristics [1]:

- Having the same radiating aperture, the directivity of a Fresnel reflector is lower than a parabolic reflector. This is a logical consequence of the Fresnel reflector definition, and increasing (up to 1 dB using 4 levels) the number of levels (steps in the transversal section of reflector as is defined in the Reference [2]), the difference between Fresnel and parabolic reflector directivities can be reduced. Therefore, parabolic reflectors must be considered the limit and consequently an utopia for Fresnel reflectors.
- When the family of Fresnel zones is based on concentric

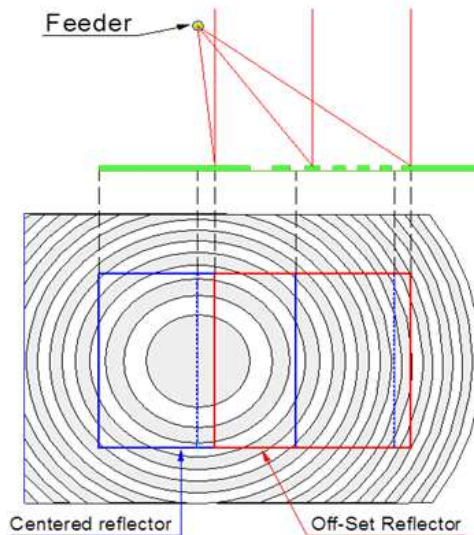

**Figure 1.** Comparison between centred and off-set reflector, in both cases the main beam being in the normal direction to the reflector surface.

circumferences and independently of the illuminated area, the reflecting signal is perpendicular to the Fresnel surface (it is not necessary to illuminate complete zones to focalise the signal). Thus using an off-set configuration (Figure 1), it is possible to avoid the feeder shadow over the reflector's main beam [3].

- Another possible off-set configuration to avoid the feeder shadow is using a tilted beam. In this case, the family of Fresnel zones is based on ellipses [2], but as can be seen in the case of the Fresnel reflector which is shown in Figure 2, with the naked eye it is difficult to appreciate that the ellipses are indeed ellipses or circumferences. The global shape of this reflector is a disc, and only near to the edge is it possible to appreciate the real elliptical edge of the Fresnel zones.

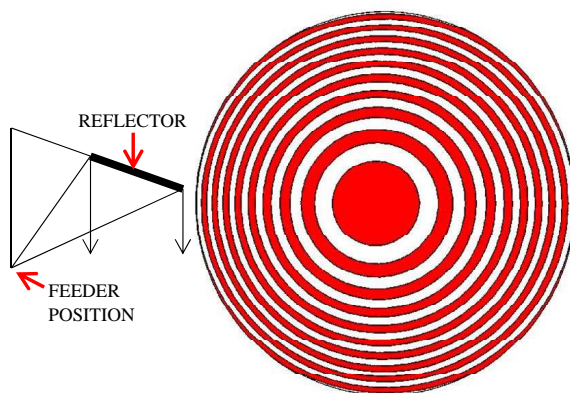

**Figure 2.** Circular Fresnel reflector with elliptical plate zones. X band, 2 m diameter, focal point at 2.4 m from the reflector centre, with a tilted beam at  $15.2^\circ$  measured from the normal to the Fresnel surface.

- In the case of parabolic reflectors, the position of the feeder is critical, and any axial or lateral deviation in the feeder position (away from the focal point), introduces an important reduction in the surface efficiency [4–6].
- In the case of a Fresnel reflector, it is known that at each plate zone, the central radial part provides the main contribution to the total reflected radiation (Figure 3), so from the point of view of the reflected signal, the position of the edge shape of each zone is not relevant because the edge is the zone part with the least contribution to the signal focusing.

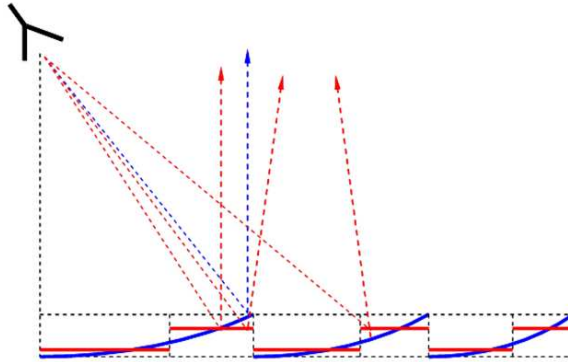

**Figure 3.** Difference of phase at the edge of Fresnel plate zones: only in the zones where the Fresnel reflector is coincident with parabolas is the sum of phase coherent in the vertical direction.

Depending on the size of the required bandwidth, this latter feature enables the use of applications which are impossible with parabolic reflectors. One of them for example, is the active beam scanning capability which is described in Reference [7], in which it was demonstrated that a family of Fresnel zones based on concentric circumferences can focus signals from any angle of incidence. In this case, the reflector surface is formed by a planar structure of small square cells, which can be placed at two different positions in the vertical direction. They provide changes in the Fresnel zones varying the beam pointing of the reflector. Obviously the edges of zones are not perfect circumferences.

The aim of this work is to apply this property, placing several feeders around a single Fresnel lens or reflector, to find an experimental configuration similar to the retina in human eyes, where each feeder can provide information from a different angular direction because each feeder is looking at a different area. Really our idea would be to increase the number of foveas. The human eye has only one, but the falcon eye has two foveas which increase the vision capacity of falcons. This capability can be obtained by using antennas with two separated beams (as the antenna of Reference [8]), or by means of several feeders using the same lens or reflector. Consequently, we think that only a Fresnel configuration, using lens or reflector, can provide this capability.

In the case of the human eye, the crystalline lens focuses the image on the retina, but as there is only one fovea the image is formed with high resolution only in the central part, about  $5^\circ$  around the fovea (depending on the visual acuity), which is located on the crystalline

axis [9, 10]. On the contrary, if the Fresnel lens or reflector works with similar efficiency with respect to different lines of sight, the use of several feeders allows several foveas to be considered and consequently increasing the field of view or improving the image resolution.

To achieve this objective, this paper presents an exhaustive study to evaluate the behaviour of a Fresnel reflector in W band (from 75 to 110 GHz), placing the feeder in different positions, outside the focal point. The idea is to carry out measurements by placing the feeder at different angular positions with respect to the two-level Fresnel reflector (according to the level definition in [2]). In this frequency band, the assembly and positioning of the horn antennas with respect the reflector, and even the environment of the device, are critical in the measurement process, and they must be taken into account in the result analysis. For example, one of the drawbacks in this frequency band is the separation between antennas, which is limited by the length of the cables connecting to the vector analyzer (a separation of 1 m approximately). As a consequence of these problems, the experimental device was designed to minimise these effects. To have a control the measurement quality, we have defined a protocol to confirm the low level of the reflection coefficient at both ports after each change of the horn position, for which we use as reference the behaviour of a flat metal surface of the same size as the Fresnel reflector.

## 2. DESIGN OF THE EXPERIMENTAL SET-UP

As we have seen in the previous section, the objective of the experimental system is to measure the transmission coefficient between two horn antennas in the W band (from 75 to 110 GHz), one of them being the feeder of a Fresnel reflector. The idea is to place both horn antennas at different angular positions with respect to the reflector, so we have separated the design of the system in the following steps: design of the Fresnel reflector, design of the experimental set-up and definition of the measurement process.

### 2.1. Design of the Fresnel Reflector

Following the design guidelines of Fresnel reflectors which are described in References [10, 11], for a reflector with two levels of circular Fresnel plate zones, the structure shown in Figure 4 has been chosen. The reflector has been designed with 6 Fresnel zones on two levels and it is etched on a square aluminium plate. Its operating centre frequency is 96 GHz and it has a focal length of 100 mm. The geometrical parameters can be seen in Table 1.

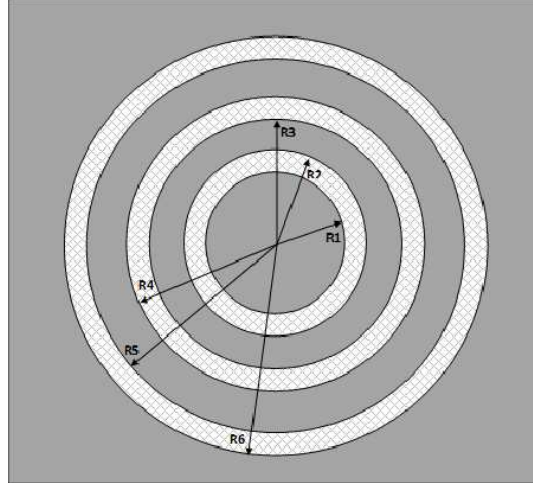

**Figure 4.** Layout of the Fresnel reflector.

**Table 1.** Geometrical parameters of the Fresnel reflector.

DESCRIPTION	PARAMETER	VALUE
1st Fresnel radius	$R_1$	12.6 mm
2nd Fresnel external radius	$R_2$	22 mm
3rd Fresnel external radius	$R_3$	28.3 mm
4th Fresnel external radius	$R_4$	33.9 mm
5th Fresnel external radius	$R_5$	38.2 mm
6th Fresnel external radius	$R_6$	42.8 mm
Fresnel level separation	$h$	0.78 mm
Square reflector side	$L$	145 mm
Thickness of reflector	$W$	10 mm

## 2.2. Design of the Experimental System

In Figure 5, a scheme of the experimental system is shown, where a dielectric arm can be seen to support the reception horn whose mission is to focus the signal reflected by the Fresnel reflector, which arrives from the far-field horn emitter. This dielectric arm has several holes to place the receiver horn antenna at different angular positions with respect to the centre of the plate of the Fresnel circular zones. In order to adequately adjust the feeder, these positions are limited to an angular separation of  $5^\circ$ , so the selected angular positions are:  $50^\circ$ ,

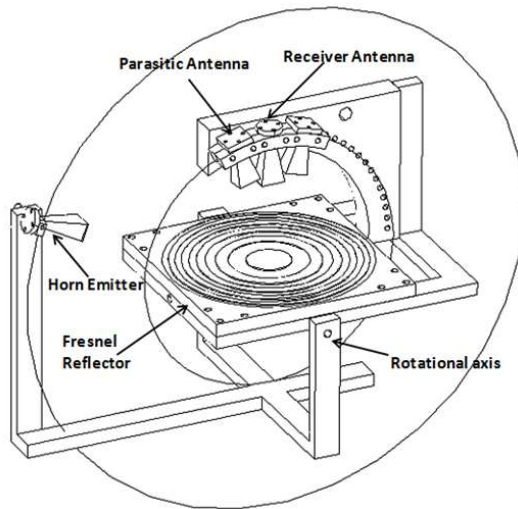

**Figure 5.** Experimental device perspective. Circles show the two directions of rotation on the angular positions of the horn.

45°, 40°, 35° and 30°. These positions are the elevation angles from the reflector surface.

The transmitting antenna is pointed to the centre of the reflector with a known elevation angle relative to the Fresnel plane. This angle is varied by turning together the horn-reflector system on an axis located in the Fresnel centre, as shown in Figure 5. These angle variations can be controlled by an accurate inclinometer placed on the reflector. This rotational movement enables measurements to be made from different angles of the emitter antenna. Figure 6 shows a detail of the measurement system, where it can be seen that the receiving antenna is located between two loaded antennas to simulate the effect of coupling between them. Although in this demonstrator there are only two parasitic antennas, in the case of a full sensor formed by an array spatial of receivers, each receiver would be surrounded by others in the other two directions of space.

### 2.3. Measurement Process

The measurement process consists of the characterization of the transmission coefficient ( $S_{21}$ ) between a couple of similar horns using a vector analyser with extensions for working at W band, as can be seen in Figure 6. As one of the horns (the emitter in Figure 5) is placed at far field with respect to the reflector and the other one is used to focus

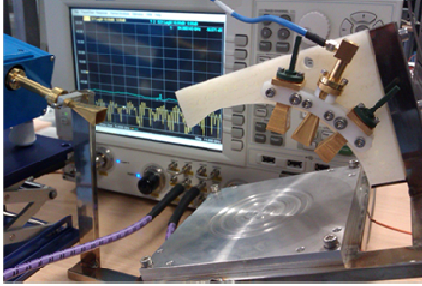

**Figure 6.** Detail of the measurement system.

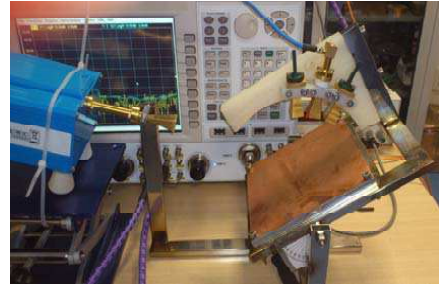

**Figure 7.** Measurement system with the metallic sheet. Both horns are placed at  $50^\circ$  of elevation in specular direction.

the signal reflected over the Fresnel reflector, this  $S_{21}$  parameter can also be used to obtain a measurement of the radiation pattern of the antenna formed by the reflector and its feeder (the horn placed on the focal point).

In order to obtain a reference level, a flat metallic reflector of the same size as the Fresnel reflector has been measured. Flat metallic reflector performance can be determined easily by different ways (measured or calculated). The change between reflectors (Fresnel and flat metallic sheet) can be performed easily without changing the geometrical or electrical conditions. A detail of the measurement system with the metallic sheet can be seen in Figure 7. The measurement repetivity is assured by controlling of the reflection coefficient at both inputs to the horns, which confirms the correct positioning of the waveguides.

There are two different kinds of measurements, in both cases, the transmission coefficient between the two antenna horns has been characterized:

- One of them consists of placing both horns at specular angular positions. These angular positions depend on the holes of the dielectric arm, so they are:  $30^\circ$ ,  $35^\circ$ ,  $40^\circ$ ,  $45^\circ$  and  $50^\circ$  of elevation versus the reflector surface. At each angular position the transmission coefficient is measured from 75 to 110 GHz.
- The second one is carried out by placing the antenna horn at the Fresnel focus on the dielectric arm at position of  $45^\circ$  of elevation and the other one at several degrees of elevation (from  $30^\circ$  to  $47^\circ$ ). At these positions, two different kinds of measurements have been carried out; one of them with the Fresnel reflector and the



other one with the flat metallic surface. This measurement is actually the radiation pattern of the assembly formed by feeder and reflector.

### 3. DISCUSSION OF EXPERIMENTAL RESULTS

Figures 8 to 12 show results of the first set of measurements. In this case, both antennas are placed in specular directions and the aperture surface of the antennas in  $H$  position ( $H-H$ ), the elevation angles vary from  $30^\circ$  to  $50^\circ$ . These graphs show the following properties:

- The  $S_{21}$  parameter value of the Fresnel reflector for low elevation angles ( $30^\circ$  in Figure 8), in the working frequency band, is lower than the value obtained with the metallic plane surface. On the contrary, for high elevation angles ( $45^\circ$  in Figure 11 and  $50^\circ$  in

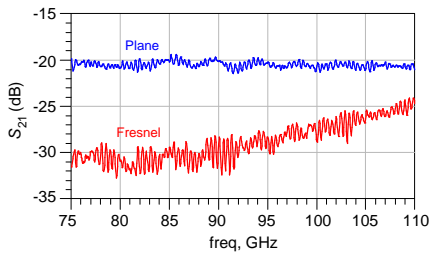

**Figure 8.** Transmission coefficient versus frequency. Both horns placed at specular position ( $H-H$ ) for  $30^\circ$  of elevation.

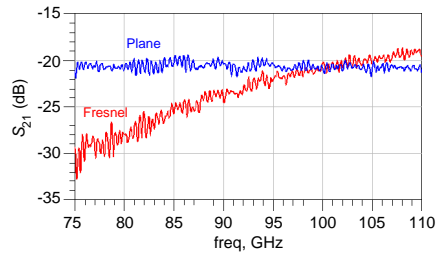

**Figure 9.** Transmission coefficient versus frequency. Both horns placed at specular position ( $H-H$ ) for  $35^\circ$  of elevation.

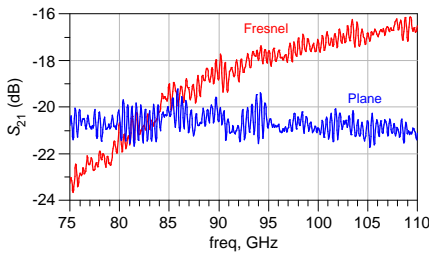

**Figure 10.** Transmission coefficient versus frequency. Both horns placed at specular position ( $H-H$ ) for  $40^\circ$  of elevation.

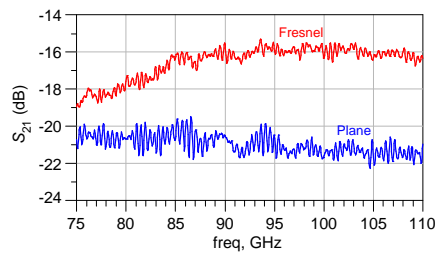
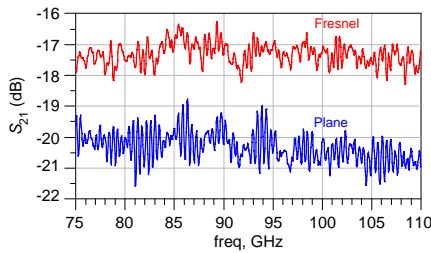

**Figure 11.** Transmission coefficient versus frequency. Both horns placed at specular position ( $H-H$ ) for  $45^\circ$  of elevation.

Figure 12), the Fresnel reflector provides greater  $S_{21}$  value than the metallic plane surface. Considering only specular positions of horns, an increase in the elevation angle results in the Fresnel reflector providing better radiation efficiency than the metallic plane surface. This is a logical consequence of the Fresnel reflector which is designed to focus the reflected signal in the normal direction.

- In Figures 8 to 11 a crossing point can be seen between the behaviour of the metal plane and the Fresnel reflector at different frequencies depending on the angle of elevation. This property is a consequence of the previous one: at elevation angles between  $30^\circ$  and  $50^\circ$ , the change of efficiency will present an intersection point. It can be seen at 100 GHz for  $35^\circ$  in Figure 9, and at 82 GHz for  $40^\circ$  in Figure 10. The crossing is not clear at frequencies above  $50^\circ$ , which may be because the crossing point is outside of the frequency band.
- For a specific frequency (it could be the design frequency for example), when the elevation angle increases, the value of the transmission coefficient between horns also increases up to a value of about 5 dB over the result obtained with the metallic plane surface. This value is found at  $45^\circ$  of elevation (Figure 11), and is stable in a bandwidth of 25 GHz (about 25%). As can be seen in Figure 12, this value is also stable for higher elevation angles. This value of 5 dB demonstrates the efficiency improvement provided by the use of a Fresnel reflector when compared with the behaviour of a metallic plane surface. On the other hand, Figure 12 shows a small problem of ripple for high elevation angles (in the case of  $45^\circ$  and  $50^\circ$ ), which is due to the presence of the dielectric arm in the path of the radiation. A detail of this problem can be seen in Figures 6 and 7.

As is well known, a two-level Fresnel reflector focus the signal because the level separation is designed to be  $\lambda/4$ , so the reflected signals in the even zones are in phase with the reflected signal in the odd zones. However this value of  $\lambda/4$  is only suitable for the normal direction. Obviously, for other elevation angles (different to the normal direction), the electrical path to provide this effect on the reflected signal in the bottom level is greater than the nominal separation between levels. As the length of this path depends on the cosecant of the elevation angle, the bandwidth is not too small. As was mentioned before, Figures 11 and 12 show 25% of bandwidth. This is a good value for many different applications. When the application requires low values of elevation angles, the level separation must be optimised.



**Figure 12.** Transmission coefficient versus frequency. Both horns placed at specular position ( $H-H$ ) for  $50^\circ$  of elevation.

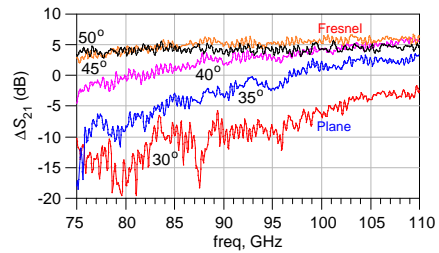

**Figure 13.** Evolution of the magnitude of the  $S_{21}$  parameter of the Fresnel reflector over the  $S_{21}$  parameter of metallic surface, versus the frequency. Position of the horns ( $E-E$ ).

Figure 13 shows the ratio between the Fresnel reflector and the metallic surface, versus frequency. In this case, to test the Fresnel performance in any situation, both antennas are also placed in specular directions but with the aperture surface of the antennas in  $E$  position ( $E-E$ ). In this set of measurements, the behaviour of the metallic surface is used as reference. In Eq. (1) the ratio in dB of the Fresnel transmission coefficient, referred to the ideal metallic plane considered, is calculated.

$$S_{21} \text{ (dB)} = 20 \cdot \log \left( \frac{|S_{21}|_{\text{Fresnel}}}{|S_{21}|_{\text{metallic plane}}} \right) \quad (1)$$

Five angular positions with both horn antennas have been represented in Figure 13. These results demonstrate that the Fresnel performance, in terms of efficiency, is better than the metallic surface for angular positions greater than  $40^\circ$ .

Figure 14 shows the enveloping trace of the difference between gain maxima of the two radiation patterns (Fresnel pattern and metallic surface pattern), defined by Eq. (2), versus the angular position of the feeder, where the working frequency is the parameter represented in the graph. In this case, the traces are not radiation patterns but the envelope of the various radiation patterns, each one at a different angular position of the feeder.

$$\max[\Delta(S_{21})] \text{ (dB)} = 20 \cdot \log \left( \frac{\max(|S_{21}|_{\text{Fresnel}})}{\max(|S_{21}|_{\text{metallic plane}})} \right) \quad (2)$$

These results provide very clear evidence of the better behaviour of the Fresnel reflector compared to a metallic surface. This property depends

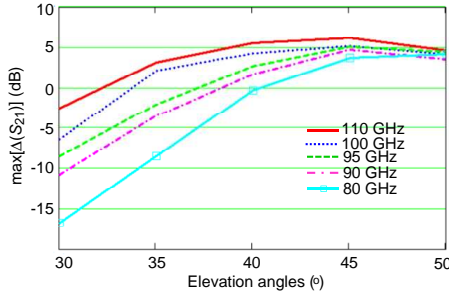

**Figure 14.** Envelope of the relationship between maxima of the radiation patterns [Eq. (2)] versus the angular positions of the feeder for different values of frequency.

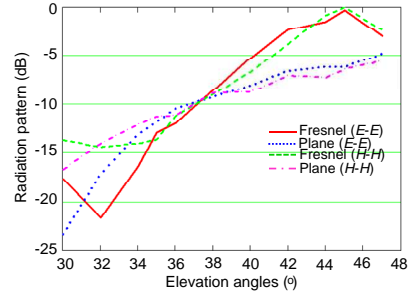

**Figure 15.** Radiation patterns at 95 GHz with the focal feeder at 45° of angular position.

on the frequency and the angular position and not only for elevation angles over 40° as we deduced previously. On the other hand, Figure 14 confirms the stability of the maximum value of about 4 dB (5 dB in some angular positions of the feeder), for the difference between the Fresnel reflector and the metallic surface.

As the results in Figure 14 are obtained from measurements using the Fresnel reflector itself, this figure also demonstrates the evolution with frequency of the limit of the angular coverage, maintaining all geometric characteristics of the reflector. Remembering that the Fresnel reflector was designed for 96 GHz for normal incidence and assuming that a performance of 3 dB over the behavior obtained with a metallic surface is good, Figure 14 shows the position of the limit at 110 GHz that is placed at 35° of elevation angle, at the design frequency (96 GHz) at 40°, and at 80 GHz near to 45°.

In Figure 15 the radiation pattern of the Fresnel reflector and the plane metallic surface is shown for the case when the feeder is placed at 45° of elevation. There are two traces per reflector ( $E-E$  and  $H-H$ ) depending on the position of the feeders with respect to the reflector surface.  $E-E$  implies that both horns have the  $E$  field perpendicular to the reflector surface and in the case of  $H-H$  the  $E$  field is parallel. The angular interval in these figures is 30° to 47°, from measurements made with a non uniform step of 2° and 1°. This Figure is really the meridional cut of the radiation pattern which contains the main beam, and it is a clear evidence of the limits and tolerances of the manufacturing and measurement processes because the maximum of the radiation pattern is obtained at 45° (as was expected), but the traces present a ripple of about 1 dB.

#### 4. CONCLUSIONS

This paper describes an exhaustive study to evaluate the behaviour of a Fresnel reflector in W band. The measurements have been carried out by placing the feeder at different angular positions with respect to a two-level Fresnel reflector. As we have mentioned, at this frequency band the system assembly and positioning of the horn antennas with respect the reflector are critical in the measurement process so an experimental set up has been developed that controls the low level of the reflection coefficient at both ports, after each change of the horn position. As a reference, the behaviour of a flat metal surface of the same size as the Fresnel reflector has been used. The experimental results showed good stable behaviour of the gain versus the angular position of the feeder.

The measurements made in this work have demonstrated that the focal position of a Fresnel reflector is not a single point and it depends on the direction of arrival of the signal. Therefore, several feeders can be placed over the same reflector where each one has a different field of view, and consequently an improvement of the total field of view could be obtained. In the case when the feeders were placed overlapping its field of view, an improvement in the resolution could be obtained by an interferometric process.

These special properties of the Fresnel reflectors, impossible for parabolic reflectors, have demonstrated that the Fresnel reflectors could be used in new applications such as radar imaging, increasing the field of view of the radar, or improving the resolution by means of several feeders working simultaneously on the same lens or reflector, as is the case of vision in the human eye.

#### ACKNOWLEDGMENT

The authors would like to thank the Spanish Ministry of Economy and Competitiveness for the financial support provided through the projects CSD2008-00068 TERASENSE, CSD2008-00066 EMET and the co-finance from FEDER funds TEC2011-29126-C03-01. The authors wish to express their gratitude to Santiago Blanes for his valuable comments and indications on the operation of the human eye.

#### REFERENCES

1. Minin, O. V. and I. V. Minin, *Diffractional Optics of Millimetre Waves*, IoP Publishing Ltd., 2004, ISBN: 07503090775.

2. Gutiérrez-Ríos, J. and J. Vassal'lo, "Technological aspects of Fresnel zone reflectors," *Advances on Antennas, Reflectors and Beam Control*, Chapter 4, 85–114, Research Signpost, 2005, ISBN 81-308-0067-5.
3. Vassal'lo, J., "Recent developments of the INTA/CSIC collaboration on antennas," *7th International Symposium on Recent Advances in Microwaves Technology, ISRAMT' 99*, Málaga, Spain, 1999.
4. Ruiz-Cruz, J. A. and J. L. Masa-Campos, "Antennas and circuits of high frequency," Theme VII, Second Part, Master on Informatics and Telecommunication Engineering, Autonomous University of Madrid, Aug. 2007.
5. Li, B., K. J. Lee, H. T. Chou, and W. Gu, "A polarization compensation approach utilizing a paraboloid photonic-crystal structure for crossed-dipole excited reflector antennas," *Progress In Electromagnetics Research*, Vol. 85, 393–408, 2008.
6. Bolli, P., G. Mazzarella, G. Montisi, and G. Serra, "An alternative solution for the reflector surface retrieval problem," *Progress In Electromagnetics Research*, Vol. 82, 167–188, 2008.
7. Gutiérrez-Ríos, J. and J. Vassal'lo, "New reflector technology with reconfigurable beam pattern," *29th ESA Antenna Workshop on Multiple Beams and Reconfigurable Antennas*, Noordwijk, Netherlands, Apr. 2007.
8. Pedreira, A. and J. Vassal'lo, "Conformed beams using Fresnel's zones flat reflectors," *4th COST 260 Workshop on Smart Antenna Design and Technology, European Action COST 260*, Rennes, France, Oct. 2000.
9. Le Grand, Y., *Form and Space Vision*, Indiana University Press, Bloomington, 1967.
10. Hristov, H. D., *Fresnel Zones in Wireless Links, Zone Plate Lenses and Antennas*, Artech House, 2000, ISBN 0-89006-849-6.
11. Minin, I. V. and O. V. Minin, *Basic Principles of Fresnel Antenna Arrays*, Springer-Verlag, 2008, ISBN 978-3-540-79558-2.