

COUPLING CROSS SECTION AND SHIELDING EFFECTIVENESS MEASUREMENTS ON A COAXIAL CABLE BY BOTH MODE-TUNED REVERBERATION CHAMBER AND GTEM CELL METHODOLOGIES

Y. J. Wang and W. J. Koh

DSO National Laboratories
20 Science Park Drive, Singapore 118230

C. K. Lee

School of EEE
Nanyang Technological University
Nanyang Avenue, Singapore 639798

Abstract—The field-to-cable coupling cross section is proposed to evaluate the coupling performance of a single-braided coaxial cable. In addition, a new definition for the coax shielding effectiveness is suggested. Both the coupling cross section and the shielding effectiveness of a 1.25 m-length RG 58 C/U 50 Ω coax are measured by employing both the mode-tuned reverberation chamber and GTEM cell methodologies. The detailed measurement set-ups and results are presented. The mode-tuned reverberation chamber methodology is proven to be beneficial for assessing the cable shielding and coupling characteristics over a wide frequency range.

1 Introduction

2 Definitions of Coupling Parameters

3 Measurement Methodologies

4 Results and Analyses

4.1 Coupling Cross Section

4.2 Shielding Effectiveness

5 Conclusions

References

1. INTRODUCTION

One major consideration with the design and use of coaxial cables, connectors and accompanying cable assemblies in modern electronic systems is the amount of radio frequency (RF) or microwave leakage coupling into both the systems and subsystems via the connecting cables. To facilitate system and subsystem designs, it is necessary to determine both the coupling performance and shielding effectiveness (SE) characteristics of cables and connectors that interconnect various components, subassemblies, equipment, and subsystems. The methodologies measuring the coupling and SE of cables and connectors have been the subject of a great deal of research and development for some time.

The shielding industry in the area of cables and connectors has proposed a myriad of measurement techniques and procedures, hardware and software designs, literature descriptions, test standards and guidelines, and practices [1]. These are inclusive of an open area test site (OATS), anechoic (or semianechoic) chamber, absorber-lined OATS, TEM cell, gigahertz TEM (GTEM) cell, and other shielding rooms, among which the mode-tuned reverberation chamber (RC) methodology is regarded as the most convenient and promising one [2–4] to measure the SE of cables and connectors over a wide frequency range.

On the other hand, there are various parameters to characterize the performance of the coaxial cables and connectors, like SE and transfer impedance [1, 7]. However, to assess the possible power coupled by coaxial cables connected to the system in the field-to-cable coupling case, the coaxial cables can be regarded as the receiving antennas [8–10]. They will pick up the coupled power from the external electromagnetic interference (EMI) against the operational reliability of both the system and subsystems. The coupling cross section is thus resulted in this paper to evaluate the field-to-cable coupling performance of the coaxial cables. Both the coupling cross section and the shielding effectiveness of a 1.25 m-length RG 58 C/U coaxial cable under test are measured by the use of the mode-tuned RC and GTEM cell ((GC) methodologies.

2. DEFINITIONS OF COUPLING PARAMETERS

The shielding effectiveness data are typically required for various coaxial cables (coax) to facilitate system design. The SE is the capability of a shield, such as a coax and a metallic enclosure, to screen out electromagnetic (EM) fields. Similar to the definition for

the enclosure SE [11], the coax SE in this paper is defined by relative incident powers into the cable with and without the cable shield as follows

$$SE = 10 \log \frac{P_{\text{rec,wire}}}{P_{\text{rec,coax}}} \quad (1)$$

where $P_{\text{rec,coax}}$ is the received power with the shield for a given power illuminating the coax, and $P_{\text{rec,wire}}$ is the received power without the shield for the same power illuminating the stripped center conductor of the coax.

It should be noted that this coax SE definition is slightly different from the conventional SE definition for the coax, where $P_{\text{rec,wire}}$ is normally replaced by the received power, P_{ref} , by a reference antenna for the same power illuminating the coax under test [2, 3]. As P_{ref} and $P_{\text{rec,wire}}$ may not respond identically within the same frequency range of interest, $P_{\text{rec,wire}}$ is preferable to the P_{ref} in the case of evaluating the efficiency of the cable shield (or screen) itself.

Moreover, the awareness of the threat posed by RF or microwave radiation of high intensity against the operational reliability of coaxial cables is increasingly attracting attention. The power picked up by the coax connected to the system is also to be assessed for analyzing the susceptibility of the system. The approach is to regard the coax as a coupling antenna to receive externally illuminated RF or microwave power. Analogous to the definition of the antenna cross section [5], the coupling cross section of the coax, $\sigma_{\text{c,coax}}$, is also defined here to quantify the coupling performance of the coax in the field-to-cable coupling case by

$$\sigma_{\text{c,coax}} = \frac{P_{\text{rec,coax}}}{S_{\text{inc}}} \quad (2)$$

where $P_{\text{rec,coax}}$ is the power received by the coax, and S_{inc} is the scalar power density of the incident field illuminating the coax.

This parameter is useful, as the coupled power to the coax can be easily obtained if the power density surrounding the coax is known.

Within the GC, the received power, $P_{\text{rec,coax}}$, is averaged over the sampling cable layouts, because the electromagnetic pick-up by the cable may be affected by the cable arrangement. The incident scalar power density, S_{inc} , is detected and space-averaged by an isotropic electric-probe. In this study, four horizontal cable layouts with 90-degree orientation are considered, while four space samplings are used to obtain power density average value at individual sampling frequency within the “working volume” of the GC.

When tested in the mode-tuned RC, both the received power, $P_{\text{rec,coax}}$, and the incident scalar power density, S_{inc} , are averaged over

all the tuner positions of interest, which results in

$$\sigma_{c,\text{coax}} = \frac{\langle P_{\text{rec,coax}} \rangle}{\langle S_{\text{inc}} \rangle} \quad (3)$$

In the mode-tuned RC, the incident scalar power density, $\langle S_{\text{inc}} \rangle$, is given by [6]

$$\langle S_{\text{inc}} \rangle = \frac{8\pi}{\lambda^2} \langle P_{\text{rec,cal}} \rangle \quad (4)$$

where $\langle P_{\text{rec,cal}} \rangle$ is the average power received by a field calibration antenna over all the tuner positions, and λ is the wavelength of the sampling frequency in the free-space.

The calibration antenna is assumed to be lossless and well impedance-matched in Equation (4). Thus, Equation (3) in the mode-tuned RC becomes

$$\sigma_{c,\text{coax}} = \frac{\lambda^2}{8\pi} \frac{\langle P_{\text{rec,coax}} \rangle}{\langle P_{\text{rec,cal}} \rangle} \quad (5)$$

Using the similar procedure, the coupling cross section of the stripped center conductor of the coax (without the cable shield) can be expressed as

$$\sigma_{c,\text{wire}} = \frac{\lambda^2}{8\pi} \frac{\langle P_{\text{rec,wire}} \rangle}{\langle P_{\text{rec,cal}} \rangle} \quad (6)$$

where $\langle P_{\text{rec,wire}} \rangle$ is the average power received by the stripped center conductor over all the tuner positions, and $\langle P_{\text{rec,cal}} \rangle$ and λ have the same meanings as above.

If both $\sigma_{c,\text{coax}}$ (with the cable shield) and $\sigma_{c,\text{wire}}$ (without the cable shield) are determined and expressed in the unit of dBsm (dB square meter), the SE of the coax over the same frequency spectra can be readily related to the coupling cross sections by

$$\text{SE} = 10 \log \frac{P_{\text{rec,wire}}}{P_{\text{rec,coax}}} = \sigma_{c,\text{wire}}(\text{dBsm}) - \sigma_{c,\text{coax}}(\text{dBsm}) \quad (7)$$

3. MEASUREMENT METHODOLOGIES

It is desirable, when conducting the field-to-cable coupling cross section and coax SE tests, to isolate the test space from the exterior EM environment. This isolation can be achieved by placing the equipment under test (EUT) in a metallic enclosure or chamber. In order to find the worst possible interference in a screened chamber, it is necessary to rotate the EUT as the chamber contains a well-defined and inhomogeneous EM field. But this rotation is often impossible.

Therefore a “uniform” environment must be reversely created within the chamber, which could decrease the dependence of the EUT on its location and orientation. Such a uniform EM environment can be created by rotating one or more conductive tuners (reflectors or stirrers) in the chamber. This kind of chamber is known as a mode-tuned (stepped rotating) or mode-stirred (continuous rotating) RC.

The mode-tuned RC is per se an electrically large metallic cavity with high quality-factor, whose boundary conditions are continuously and randomly perturbed by the rotating conductive tuners. When sufficient modes are excited, the time-averaged fields (or power density) inside such a chamber are approximately equal in amplitude, spatially, and are formed by uniformly distributed plane waves. The field distribution at each location in the working volume of the RC is assumed to be a composite of statistically isotropic, randomly polarized and uniformly homogenous plane waves.

Measuring the field-to-cable coupling cross section and the coax SE by the use of the mode-tuned RC is a time-efficient and cost-effective methodology over broad frequency spectra. The EUT may be placed at any convenient position or orientation within the working volume of the RC, where the field uniformity is guaranteed.

A block diagram of the mode-tuned RC for the field-to-cable coupling cross section and coax SE measurements is shown in Figure

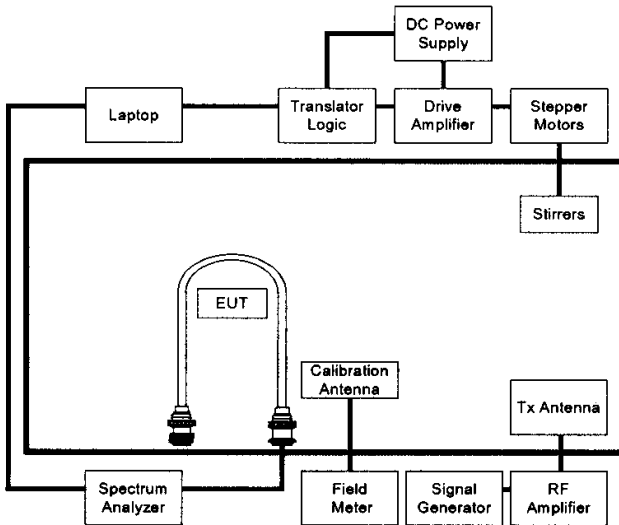

Figure 1. Block diagram of a mode-tuned RC for the field-to-cable coupling cross section and coax SE measurements.

1. The mode-tuned RC, whose dimensions are $113.6 \text{ cm} \times 77.0 \text{ cm} \times 54.5 \text{ cm}$, is essentially a lossless shielded aluminum enclosure that includes an input antenna (small horn antenna), a calibration antenna (isotropic electric-field probe), two orthogonally orientated conductive tuners, and controlling and testing accessories outside the chamber. The antennas are placed in the chamber such a way as to minimize direct coupling from the input antenna to both the calibration antenna and the EUT.

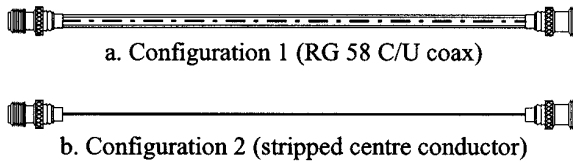

Figure 2. Two different cable configurations under test.

Figure 2 shows two different EUT cable configurations that are used to determine the field-to-cable coupling cross section and coax SE. The EUTs are fabricated from 1.25 m-length single-braided 50Ω RG 58 C/U coax. Configuration 1 is the original coax, and Configuration 2 only consists of the center conductor (stranded and tin-plated copper wires with an overall diameter of 0.90 mm), with its dielectric (PE: polyethylene), jacket (PVC 2: non-migratory polyvinylchloride) and the shield (CuSn with a diameter of 36 mm) removed from the coax. Both cable configurations are equipped with Type-N coaxial connectors. One end of either configuration is connected to a spectrum analyzer through the bulkhead connector on the chamber wall, while its opposite end is terminated with either an 50Ω , open-circuited or short-circuited load. The EUTs when testing are properly bent within the uniform working volume of the chamber and are horizontally laid 20 cm above the RC floor supported by a block of insulation Styrofoam.

Comparatively, the coupling cross section and shielding effectiveness of the EUT can also be tested by employing a GC. Figure 3 shows the measurement set-up by the GC, where the EUT is horizontally put on an insulating table. A short semi-rigid coaxial cable is used to link the EUT and the GC inlet to make sure the EUT is fully saturated within the “working volume” of the GC, where an appropriate plane wave is excited.

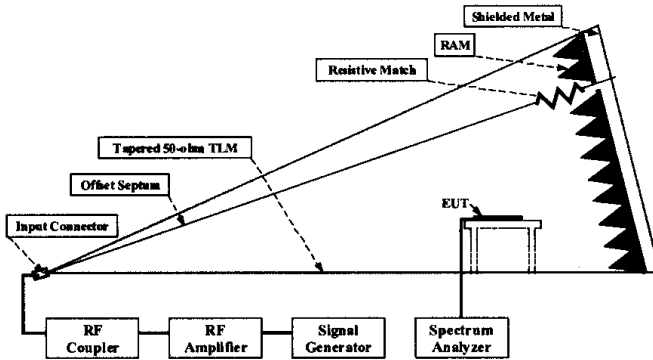

Figure 3. Measurement set-up for field-to-cable coupling cross section and SE tests using a GC.

4. RESULTS AND ANALYSES

To permit measurements of the power received by the calibration antenna or the EUT at a specific frequency, the tuner of the RC are stepped at a uniform increment of 6 degrees, which results in 60 sampling data for a complete tuner rotation. Then all the 60 sampling data of the received power at a specific frequency is averaged to give desirable measurement value. This procedure is repeated at other frequencies for both the calibration power and the coupled power into the EUT.

4.1. Coupling Cross Section

Figure 4 shows the field-to-cable coupling cross sections for both Configuration 1 (coax) and Configuration 2 (wire) within the frequency range between 8 GHz and 18 GHz. The coax is terminated with a 50Ω resistor load. The same input power is injected into the chamber through the transmitting horn antenna for both cable configurations, which will guarantee the same incident power density captured by the calibration antenna.

The coupling cross section varies obviously in either Configuration 1 or 2 over the frequency range, while the coupling cross section of the stripped center conductor (Configuration 2) is significantly larger than that of the coax (Configuration 1) at the same frequency. This logically suggests that a conductive wire be more susceptible to pick up the external electromagnetic interference (EMI) compared to the coax.

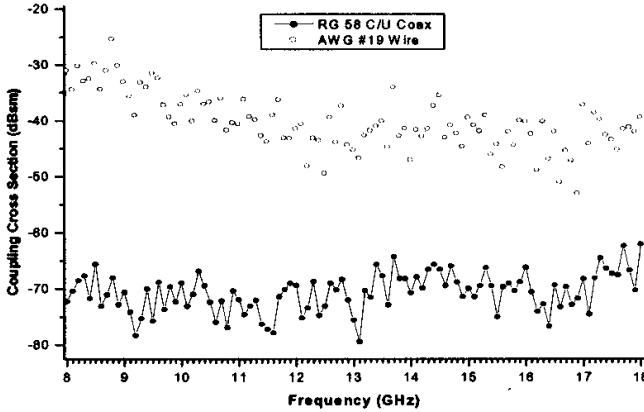

Figure 4. Measured coupling cross sections of both cable configurations.

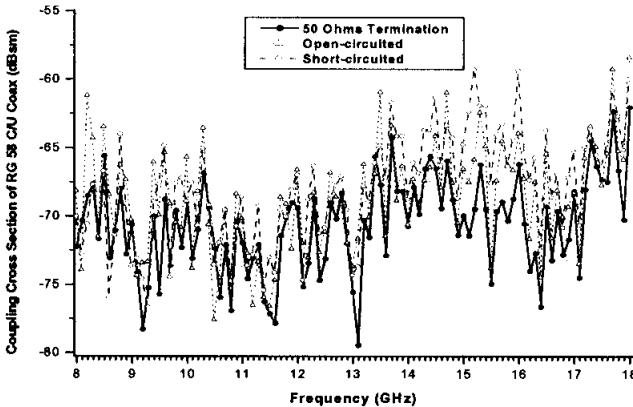

Figure 5. Coupling cross sections of RG 58 C/U coax with different terminations.

To evaluate the load termination effect on the coupling cross-section of the coax under test, three different terminations of 50Ω , open-circuited, and shorted-circuited load have also been investigated. Figure 5 shows the coupling cross section results for these three scenarios. Overall, the coupling cross section with the 50Ω termination exhibits smaller values compared to those with either the open-circuited or shorted-circuited load. This means that the impedance matching is very critical to enhance the cable immunity and reduce

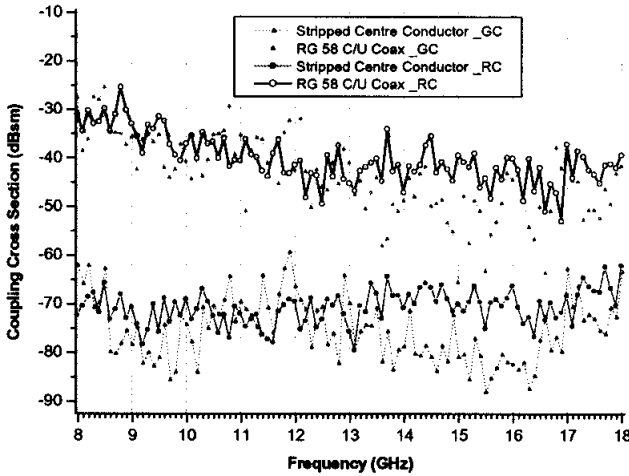

Figure 6. Comparison of coupling cross section between the RC and GC methodologies.

the coupling effect from external interference in practical applications.

Figure 6 presents the measurement comparison for the field-to-cable coupling cross section of the EUT, either the stripped center conductor or the impedance matched (50Ω) RG 58 C/U coax. The coupling cross section results by the GC exhibit more variation compared to those by the reverberation chamber, which is mainly due to the field uniformity inside the reverberation chamber. The GC results are close to the reverberation chamber results except that the GC results at some frequencies are slightly lower than the reverberation chamber results, which is owing to the linear polarization within the GC.

4.2. Shielding Effectiveness

The SE results of the coax are derived by using Equation (7) within the frequency range of interest. The measured SE results of the coax under test are shown in Figure 7, which is inclusive of three different termination cases: 50Ω , open-circuited and short-circuited. The coax with the 50Ω termination exhibits higher shielding effectiveness by several dB compared to that with either the open-circuited or shorted-circuited termination, since the coax with the 50Ω termination offers lower coupling cross section. The variation of the SE data in the 50Ω termination case is around 25 dB over the frequency range of 8–18 GHz.

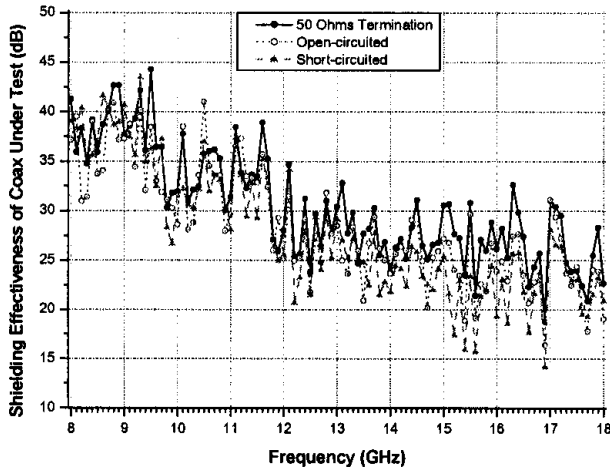

Figure 7. Measured SE of the coax with different terminations.

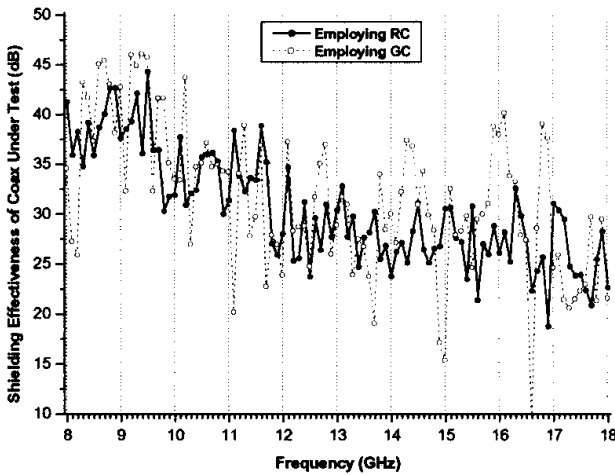

Figure 8. SE measurement comparison by using two different methodologies.

It is also noted that the coax SE is decreased significantly with the increase of frequency.

The measurement comparison by employing the two different methodologies is shown in Figure 8. A lower SE is observed in the RC methodology compared to the GC methodology, which implies the worse scenario for the RC. The reason for this is related to the random

polarization within the RC, where various polarization incidences are able to couple into the EUT. Meanwhile, the SE results by the GC exhibit larger dynamic range compared to those by the RC.

5. CONCLUSIONS

Both the coupling cross section and shielding effectiveness measurements for a 1.25 m-length RG 58 C/U coax were conducted by employing both the RC and GC methodologies.

Both the coupling cross section and shielding effectiveness measurements for the coax under test were conducted with three different terminations. The measured results indicated that the coaxial cable with the impedance-matched (50Ω) termination exhibited smaller coupling cross section and better shielding effectiveness compared to the coax with either the open-circuited or the short-circuited termination.

The coupling cross section and SE results measured by the GC exhibited larger dynamic range compared to those measured by the reverberation chamber. The coupling cross section and SE results by the reverberation chamber were generally smaller than those by the GC, which is mainly due to the random polarization and field uniformity inside the RC.

The use of the mode-tuned RC for evaluating the shielding performance of the coaxial cable is an important test methodology, one of whose advantages is that no rotation of the EUT is required over a wide frequency range. Besides the shielding effectiveness parameter, the coupling cross-section was proven to be another invaluable characteristics to assess the cable susceptibility in the field-to-cable coupling scenario.

REFERENCES

1. Tsaliovich, A., *Electromagnetic Shielding Handbook for Wired and Wireless EMC Applications*, Kluwer Academic Publishers, 2001.
2. Jesch, R. L., "Measurement of shielding effectiveness of cable and shielding configuration by mode-stirred techniques," *IEEE Trans. Electromagn. Compat.*, Vol. 30, No. 3, 222–228, Aug. 1988.
3. Crawford, M. L. and J. M. Ladbury, "Mode-stirred chamber for measuring shielding effectiveness of cable and connectors an assessment of MIL-STD-1344A Method 3008," *Proc. of IEEE International Symposium on EMC*, 30–36, 1988.

4. Johnson, D. M. and M. O. Hatfield, "Mode-stirred chamber shielding effectiveness testing of a multiconductor cable assembly," *Proc. of IEEE International Symposium on EMC*, 396–400, 1995.
5. Lo, Y. T. and S. W. Lee (Eds.), *Antenna Handbook*, Chapman & Hall, New York, 1993.
6. Hill, D. A., "Plane wave integral representation for fields in reverberation chambers," *IEEE Trans. Electromagn. Compat.*, Vol. 40, No. 3, 209–217, Aug. 1998.
7. Harris, J. M., "A comparison on bulk cable current injection and radiated field susceptibility test methods," *Proc. of IEEE International Symposium on EMC*, 67–72, Aug. 1993.
8. Backstrom, M., J. Loren, G. Eriksson, and H. Asander, "Microwave coupling into a generic object: properties of measured angular receiving pattern and its significance for testing," *Proc. of 2001 IEEE International Symposium on EMC*, 1227–1232, Aug. 2001.
9. McMahan, A. T., J. Weber, A. Prothe, and A. Pesta, "Shielding effectiveness measurements for an SHF/EHF field-to-wire coupling model," *Proc. of IEEE 1989 National Symposium on EMC*, 414–417, 1989.
10. Silfverskiold, S., M. Backstrom, and J. Loren, "Microwave fold-to-wire coupling measurements in anechoic and reverberation chambers," *IEEE Trans. Electromagn. Compat.*, Vol. 44, No. 1, 222–232, Feb. 2002.
11. MIL-STD-285, "Method of attenuation measurements for enclosures, electromagnetic shielding, for electronic test purposes," Jun. 25, 1956 (replaced by IEEE-TD-299, Oct. 24, 1997).

Y. J. Wang was born in P. R. China. He received B.Sc. (Best Hons) from Physics Department of Xiamen University, P. R. China in 1992, and M.Eng. (by research) in Electrical and Electronic Engineering from Nanyang Technological University, Singapore in 2000. From 1992 to 1998 he was an electrical engineer/a senior electrical engineer and assistant to General Manager at China Import and Export Commodities Inspection Bureau (CCIB), Fujian, P.R. China. Since November 2000, he has been working with DSO (Defence Science Organisation) National Laboratories, Singapore as a member of technical staff. He is an NARTE-certified (USA) EMC engineer. He is also a committee member of IEEE Singapore EMC chapter for years 2002–2003. Some areas of his interest are devoted to microstrip antennas, mobile antennas, numerical methods, computational

electromagnetics, test chambers, military and commercial EMC, and EMI (electromagnetic interference) troubleshooting.

W. J. Koh was born on May 13, 1957 in Singapore. He received his B.Sc. from UMIST, UK in 1979, M.Sc. from Naval Postgraduate School, California USA in 1987 and Ph.D. from Ohio State University, Ohio USA in 1995, all in electrical engineering. He has been working in DSO National Laboratories since 1981. He worked as an EMC engineer from 1982 to 1985, headed an EMC Group from 1987 to 1991. He was appointed Head of Research in EM in 95 and became Head of EM Centre in 1999. His area of interest is in RCS and EMC.

C. K. Lee was born in Malaysia. He received B.Sc. and Ph.D. degrees from the University of Kent at Canterbury, United Kingdom, in 1982 and 1987 respectively. He was a research fellow in the areas of microwave antenna majoring in frequency selective surface, at the above university between 1988 and 1990. He joined the Electro-Optic Group, Division of Radiophysics (Now renamed as Telecommunications and Industrial Physics), and Commonwealth Scientific Industrial Research Organisation (CSIRO) in Australia as a research scientist from Oct.1990 to Jul.1991 working on near field range. He is currently an associate professor in the school of Electrical and Electronic Engineering, Nanyang Technological University, Singapore. His research interests include frequency selective surface, microstrip antenna and electromagnetic inverse scattering.