

**PERFORMANCE OF A SIX-BEAM SWITCHED
PARASITIC PLANAR ARRAY UNDER ONE PATH
RAYLEIGH FADING ENVIRONMENT**

**A. I. Sotiriou, P. K. Varlamos, P. T. Trakadas
and C. N. Capsalis**

National Technical University of Athens
Department of Electrical and Computer Engineering
Division of Information Transmission Systems
and Material Technology
9, Iroon Polytechniou Str., 15773 Athens Greece

Abstract—The technology of adaptive antennas is rapidly growing during the last years. It is true that switched beam antennas, the simplest type of smart antennas, may provide substantial benefits when implemented in a cellular mobile telephony system. The performance of a six-beam switched parasitic planar array, in terms of bit error rate (BER) measurement, is presented in this paper. The switched parasitic planar array is designed with the aid of genetic algorithms method. The antenna system is evaluated in a radio environment where interfering signals are present. The results obtained from the simulation are compared with respect to the ones when an omni directional antenna is used instead of the switched beam array, revealing that the performance of such a telecommunication system can be improved.

1. INTRODUCTION

It is well known that the demand for capacity and radio coverage is rapidly increasing for third generation mobile communication systems. This is due to the growing number of users, as well as to the development of new services that require higher data rates and improved quality of service (QoS). Extensive use of antenna arrays seems to be the only way to achieve the data rates and capacities expected for those new services [1].

Nowadays, omni directional or sectored antennas, with standard radiation patterns, are employed at the base stations. In recent years, there is an enormous interest in the development and exploitation of smart antenna technology to be used in the future telecommunication systems. Multi-beam arrays and fully adaptive antennas provide important benefits regarding both radio coverage and capacity requirements.

Extended range and gap filling can be dealt with when an adaptive antenna is implemented at the base station. The gain towards the user is increased, resulting in a longer reception range. Furthermore, smart antennas can reduce or even mitigate the impact of imperfect power control since the uplink signals from different users are better isolated (near-far problem). Moreover, the power radiated from conventional base station antennas, irrespective of the user of interest location, acts as interference to all other users within the same area. This results in a degradation of system performance; namely the carrier to interference ratio (C/I) is decreasing. The incorporation of smart antennas in the communication system enables the user and base stations to operate with much lower transmit power. In that way, C/I ratio is improved and frequency reuse can be tighter, providing extra capacity to the system [2, 3].

Switched parasitic planar and linear arrays can be implemented for electronic beam steering. An appropriate N -length (where N denotes the number of antenna elements) digital codeword, consisting of 1s and 0s, is applied to the antenna feeding circuit. Each digital codeword determines a unique radiation pattern among $2^N - 1$ possible ones. The 1s and 0s represent the active and parasitic elements of the array, respectively. Linear arrays have a symmetrical radiation pattern in the azimuth plane. On the contrary, planar arrays cover the whole azimuth plane and therefore offer several main beams every $(360/q)^\circ$, where q denotes the quantity of main beams [4].

2. BASIC CONCEPTS AND THEORY: DESIGN OF A SWITCHED PARASITIC PLANAR ARRAY USING A GENETIC ALGORITHM

2.1. Switched Parasitic Planar Arrays

The mathematical model for the array factor $AF(\theta, \phi)$ of an N -dipole planar array lying in the azimuth plane is given by [4]

$$AF(\theta, \phi) = \sum_{m=1}^N c_m e^{jkr_m \sin \theta \cos(\phi - \phi_m)} \quad (1)$$

where: $c_m = \frac{I_m}{I_1}$ the relative excitation coefficients, I_m stands for the excitation current of the m -th element and I_1 the excitation of element 1.

$k = \frac{2\pi}{\lambda}$, λ being the wavelength.

$r_m = \sqrt{x_m^2 + y_m^2}$, (x_m, y_m) the azimuth coordinates of element m .

$\phi_m = \arctan(y_m/x_m)$, the azimuth angle of element m and θ the elevation angle being equal to 90° for the remainder of this paper.

The radiation pattern in the azimuth plane of a planar array whose elements are considered as dipoles of length L , is given by

$$U(\theta = 90^\circ, \phi) = A \cdot |AF(\theta = 90^\circ, \phi)|^2 \quad (2)$$

where A is a constant value depending on the radiation pattern of a single element $U_o(\theta = 90^\circ, \phi)$.

The elements excitations I_m ($m = 1 \dots N$) are related to the input voltages with equal amplitudes but different phase values, by the impedance matrix \mathbf{Z} :

$$\mathbf{V} = \mathbf{Z} \cdot \mathbf{I} \quad (3)$$

where \mathbf{V} and \mathbf{I} are the voltage and current vectors, respectively

$$\mathbf{V} = [V_1 \quad \dots \quad V_N]^T \quad (4)$$

$$\mathbf{I} = [I_1 \quad \dots \quad I_N]^T \quad (5)$$

$$\mathbf{Z} = \begin{bmatrix} Z_{11} & Z_{12} & \dots & Z_{1N} \\ Z_{21} & Z_{22} & \dots & Z_{2N} \\ \vdots & \vdots & & \vdots \\ \vdots & \vdots & & \vdots \\ Z_{N1} & Z_{N2} & \dots & Z_{NN} \end{bmatrix} \quad (6)$$

Through (3)–(6), the terminal voltage of any one element can be expressed in terms of the currents flowing in the others, mutual impedance and self impedance:

$$V_n = \sum_{m=1}^N Z_{nm} I_m \quad n = 1 \dots N \quad (7)$$

where

Z_{nm} the mutual impedance between elements n, m

Z_{mm} the self impedance of element m

The self impedance (referred to at the input current I_i) of a dipole of length L , is given by [4]

$$Z_i = -\frac{1}{I_i^2} \int_{-L/2}^{L/2} E_z(\rho = a, z) I(z) dz \quad (8)$$

where

$$I(z) = I_m \sin \left[k \left(\frac{L}{2} - |z| \right) \right] \quad (9)$$

the current distribution

E_z the tangential electric field along the surface of the dipole and

a the dipole radius

The mutual impedance (referred to at the input current I_{1i} of dipole 1) between two parallel dipoles at a distance d , is given by [4]

$$Z_{21i} = \frac{V_{21}}{I_{1i}} = -\frac{1}{I_{1i}I_{2i}} \int_{-L_2/2}^{L_2/2} E_{z21}(z) I_2(z) dz \quad (10)$$

where

V_{21} the voltage induced in dipole 2 because of the current flowing in dipole 1

E_{z21} E -field component along the surface of dipole 2 radiated by dipole 1, which is parallel to dipole 2

I_2 current distribution along dipole 2

The equations (8) and (10) can be solved and give the self and mutual impedance as functions of the ratios, and $\frac{L}{\lambda}, \frac{a}{\lambda}$ and $\frac{L_1}{\lambda}, \frac{L_2}{\lambda}, \frac{d}{\lambda}$ respectively [4].

As far as input impedance to each active element of the array is concerned, well known impedance matching techniques may be deployed [4].

2.2. Antenna Design With Genetic Algorithm

The most interesting part of this antenna design, is the use of a genetic algorithm in order to optimize the antenna performance, determining physical characteristics and feeding configuration [5]. Switched beam fully adaptive antenna arrays, have been designed with genetic algorithms that calculated elements positions, applied voltage amplitudes and voltage phase values [6]. Digital beam forming may be also achieved with switched parasitic arrays where additionally to elements positions and voltage characteristics, active and parasitic

Table 1. Directions of maximum gains, 3 dB beam widths, and relative side lobe levels for the 7-element array [7].

Digital codeword	Maximum gain direction ϕ_{\max} ($^{\circ}$)	ϕ_{-3dB}^- ($^{\circ}$)	ϕ_{-3dB}^+ ($^{\circ}$)	ϕ_{-3dB} ($^{\circ}$)	Relative side lobe level S.L.L.(dB)
0110010	31.10	2.03	55.84	53.81	-5.56
0000011	89.18	54.89	114.85	59.96	-12.41
0000001	148.12	109.00	189.49	80.49	-3.32
0101100	211.98	180.71	239.96	59.25	-3.73
1100000	276.42	240.33	310.88	70.55	-8.94
1010000	332.43	305.29	359.16	53.87	-4.14

Table 2. Element coordinates and constant phases for the 7-element array [7].

Element	$x_m(\lambda)$	$y_m(\lambda)$	$\delta_m(\text{rad})$
1	0.68269	0.29063	0.42339
2	0.87479	0.63954	2.61452
3	0.95015	0.74330	0.35733
4	0.43318	0.29939	4.74985
5	0.10149	0.31746	2.69084
6	0.39505	0.64619	4.41774
7	0.32344	0.60335	5.72366

elements are determined for each antenna pattern [7]. The latter case presents less complex configuration and lower manufacturing cost, whereas a fully adaptive antenna requires one dynamic phase shifter per element.

For the design of the antenna used in this paper, roulette wheel selection, simple crossover with $p_{crossover} = 0.8$ and binary mutation with $p_{mutation} = 0.04$ were employed [5]. The objective was to cover the entire azimuth plane with main beams every 60° having relative side lobe levels, lower than -3 dB [7]. The design was feasible by selecting the appropriate digital codeword, among the $2^N - 1$ available, which maximizes the objective function containing the pattern requirements. Each digital codeword implies which of the antenna elements are fed with current (active) and which are short-circuited (parasitic). Tables 1 and 2 provide the directional and geometrical characteristics of the designed 7-dipole array, respectively.

An RF switch is connected to each antenna element. When the

RF switch is “on”, an input voltage, equal to $V_m = A \exp(j\delta_m)$, produced by a voltage generator and a phase shifter, is applied to the element. Otherwise, the RF switch is “off” and a short circuit is applied to the antenna element. In the latter case, the voltage is equal to zero but current is induced to the parasitic element due to the active ones. For instance the digital word “0110010” refers the planar array of three active elements (elements 2, 3 and 6) and four short circuited elements (elements 1, 4, 5 and 7). The normalized voltage vector V for this feed configuration (identical voltage levels but different phase values at the active elements) is the following one $V = [0 \exp(j\delta_2) \exp(j\delta_3) 0 0 \exp(j\delta_6) 0]$.

Each dipole of the array has $\lambda/2$ length, radius $\alpha = 0,001\lambda$, and its axis parallel to the z axis while its feeding point is in the x - y plane. The 7 element array designed here may also be implemented as an array of monopoles having length equal to $\lambda/4$ being above a rectangular ground plane, whose ideal size would be $1.5\lambda \times \lambda$. Simulations at different frequencies prove that the array designed here is a narrowband one and its bandwidth is 2.5% of the carrier frequency. Table 3 provides the calculated impedance matrix Z taking into account the antenna geometry. Figure 1 presents the array configuration in the azimuth plane and Figure 2a to 2f depicts the six possible radiation patterns of the considered array in both the azimuth and elevation plane.

Table 3. Calculated impedance matrix Z .

$$Z = \begin{bmatrix} 73.1+42.2i & 66-37.4i & -16.2-26.7i & 40.9-28.3i & -22.0-18.7i & -5.3-34.2i & -8.7-32.5i \\ 6.6-37.4i & 73.1+42.2i & 63.7-1.0i & -20.2-21.8i & -14.6+15.4i & -9.3-32.1i & -19.3-23.0i \\ -16.2-26.7i & 63.7-1.0i & 73.1+42.2i & -25.2-2.4i & -1.6+19.0i & -20.4-21.4i & -25.0-9.2i \\ 40.9-28.3i & -20.2-21.8i & -25.2-2.4i & 73.1+42.2i & 21.6-36.7i & 16.4-37.5i & 22.5-36.5i \\ -22.0-18.7i & -14.6+15.4i & -1.6+19.0i & 21.6-36.7i & 73.1+42.2i & -2.2-35.4i & 14.7-37.6i \\ -5.3-34.2i & -9.3-32.1i & -20.4-21.4i & 16.4-37.5i & -2.2-35.4i & 73.1+42.2i & 69.0+12.8i \\ -8.7-32.5i & -19.3-23.0i & -25.0-9.2i & 22.5-36.5i & 14.7-37.6i & 69.0+12.8i & 73.1+42.2i \end{bmatrix}$$

It should be clarified that the asymmetrical antenna configuration, was not predetermined from the design rules, but revealed from the genetic algorithm process.

3. SIMULATION MODEL DESCRIPTION

Interference issues are and will remain the most important factors in telecommunication system performance degradation. Mitigating the impact of interfering signals may increase radio coverage and capacity, as well as improve QoS.

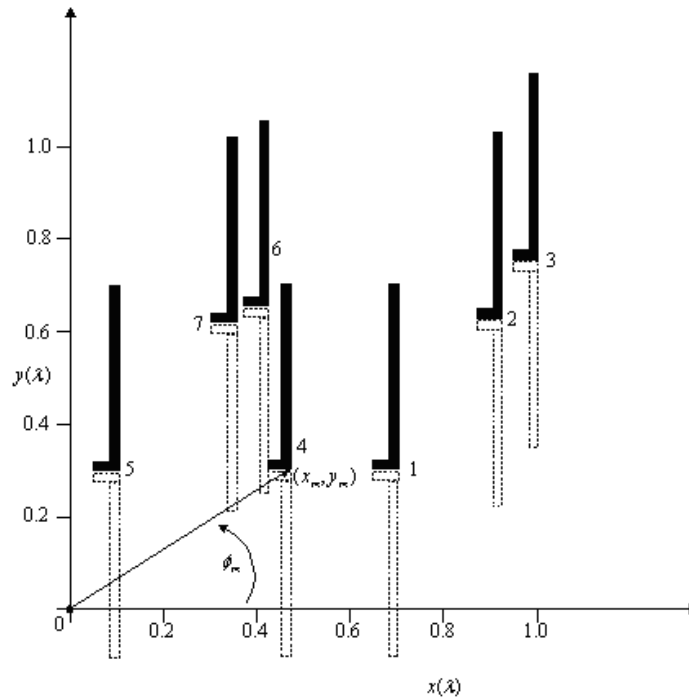

Figure 1. Geometry of the six-sector switched parasitic planar array [7].

The objective of this paper is to demonstrate the main advantages related to the use of the 7-dipole switched beam antenna array at the base station, instead of an omni directional antenna. The BER, in the uplink direction, is the criterion to show the performance improvement when the switched beam antenna is employed. The simulated system model is presented in Figure 3.

The base station is considered to operate with a macro cell while the user of interest as well as other interfering users, are randomly located within the cell range. A BPSK modulation scheme with transmission rates from 256 Kbps up to 2 Mbps is used. The modulated signal, prior to being transmitted, is passed through a root Nyquist pulse shaping filter that has roll-off factor equal to 0.5. At the receiver, the same filter is used before the demodulation process. Moreover, the TDMA frame has 200 bits/frame including a training sequence of 26 bits; hence, the normal GSM training sequences are implemented. In all cases examined hereinafter, the interferer E_b/N_o is simulated equal to 15 dB. The decision for the derived radiation pattern is utilized

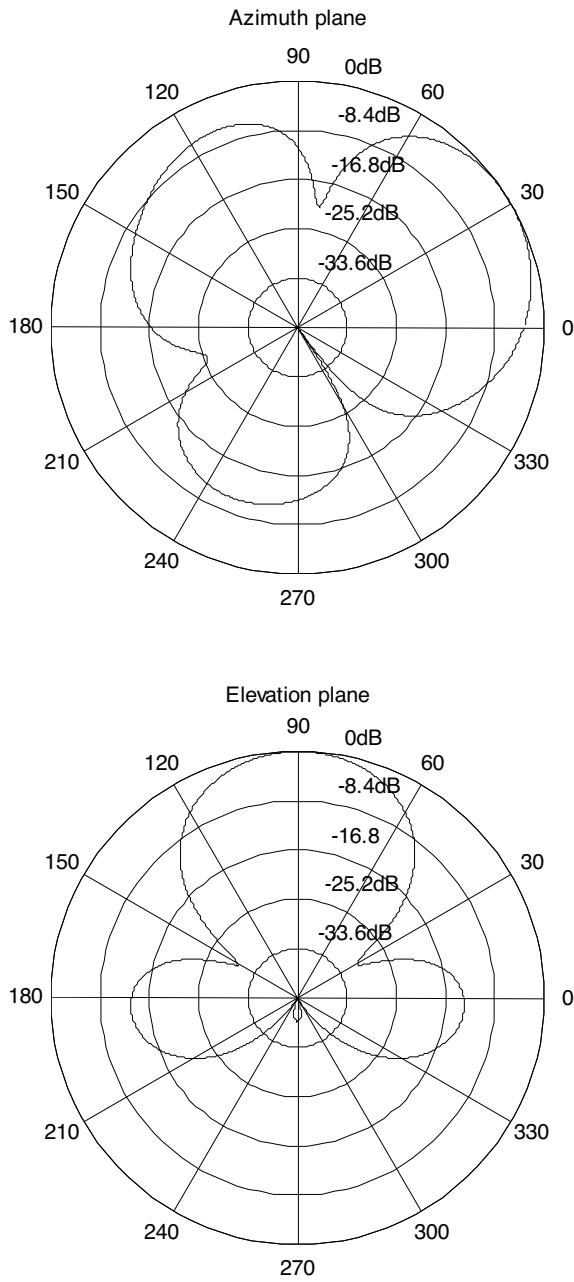

Figure 2a. Normalized radiation patterns no. 1 (in dB) in the azimuth and elevation plane of the 7-dipole planar array [7].

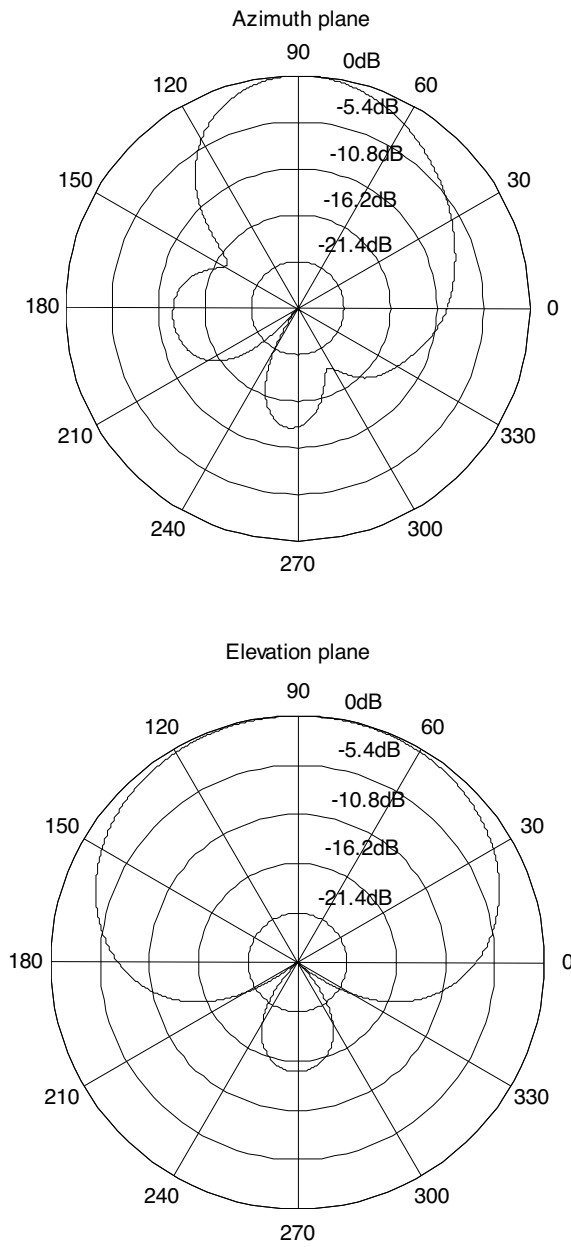

Figure 2b. Normalized radiation patterns no. 2 (in dB) in the azimuth and elevation plane of the 7-dipole planar array [7].

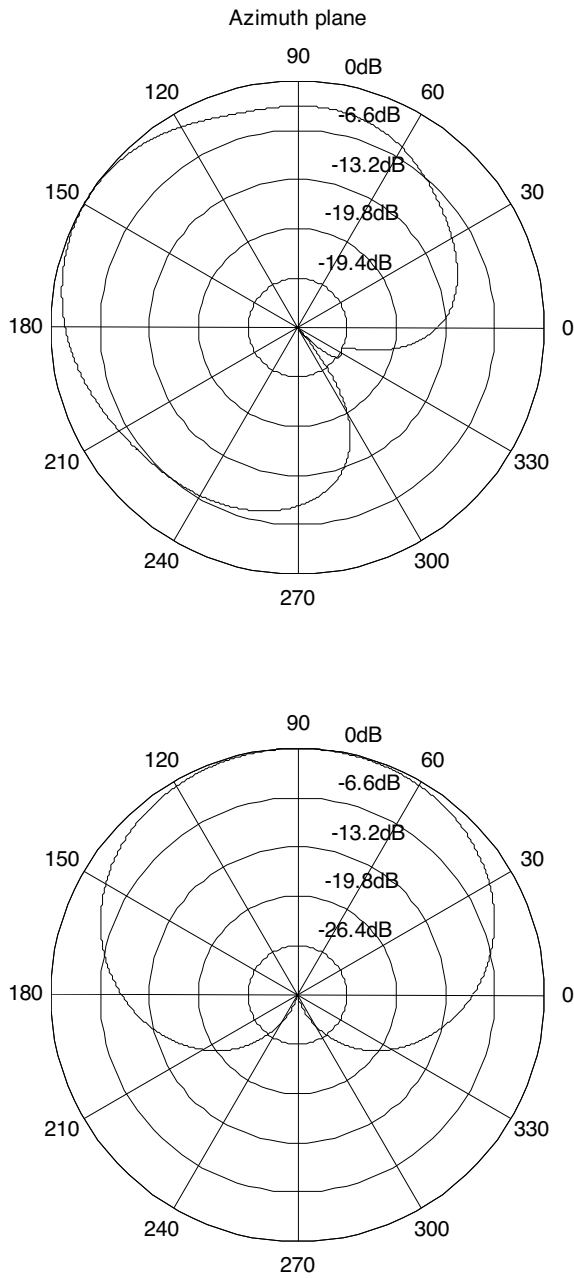

Figure 2c. Normalized radiation patterns no. 3 (in dB) in the azimuth and elevation plane of the 7-dipole planar array [7].

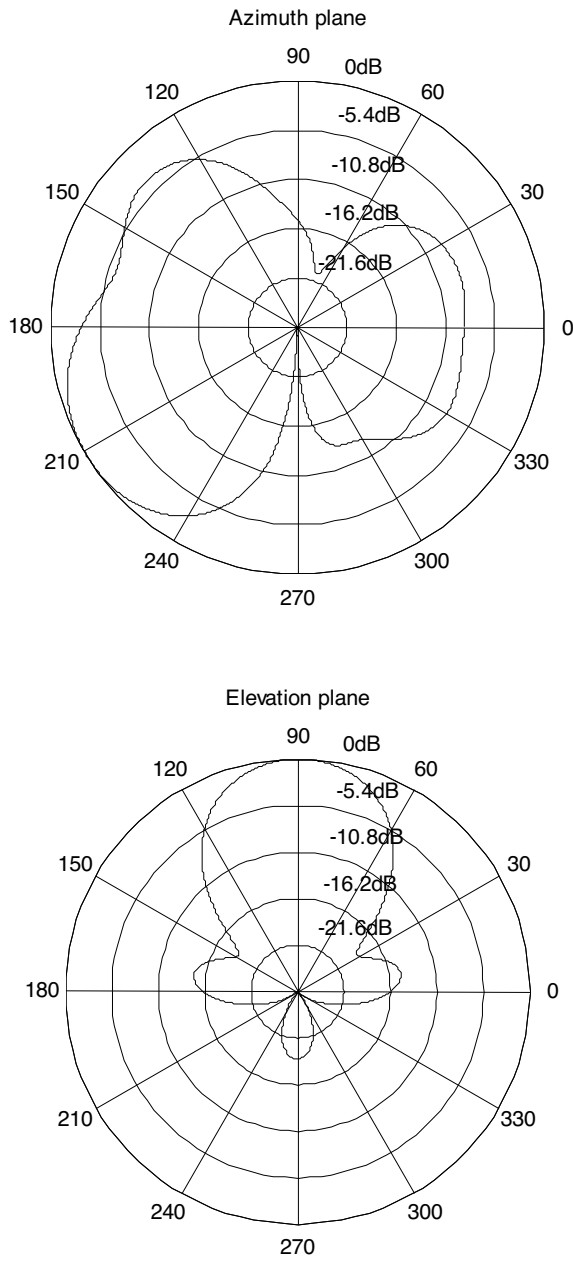

Figure 2d. Normalized radiation patterns no. 4 (in dB) in the azimuth and elevation plane of the 7-dipole planar array [7].

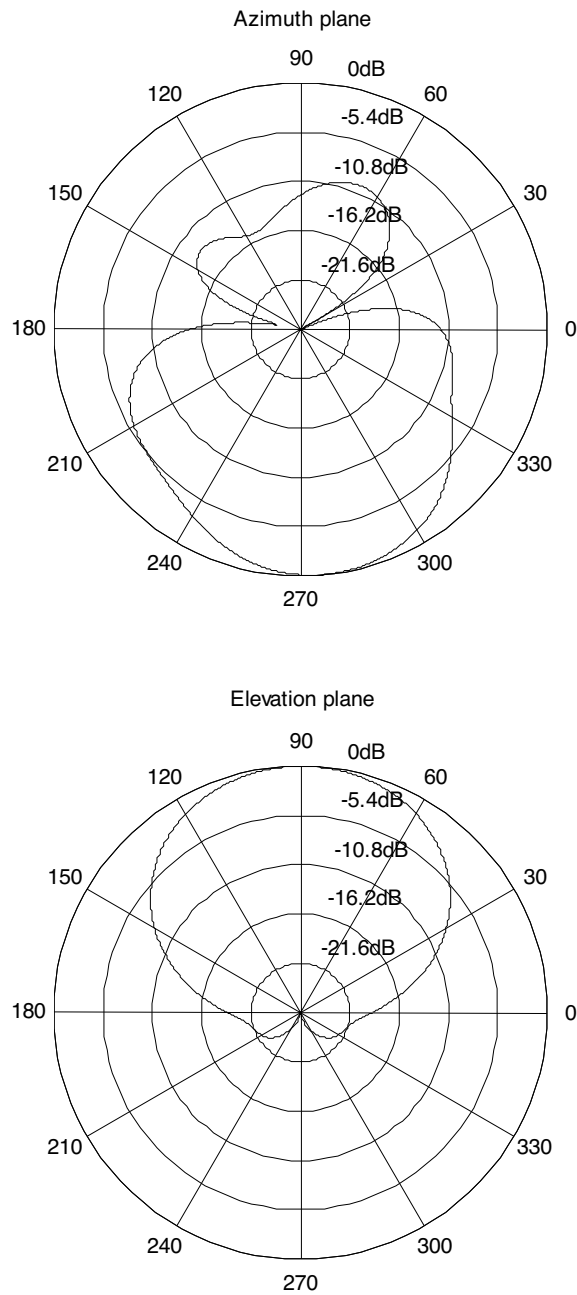

Figure 2e. Normalized radiation patterns no. 5 (in dB) in the azimuth and elevation plane of the 7-dipole planar array [7].

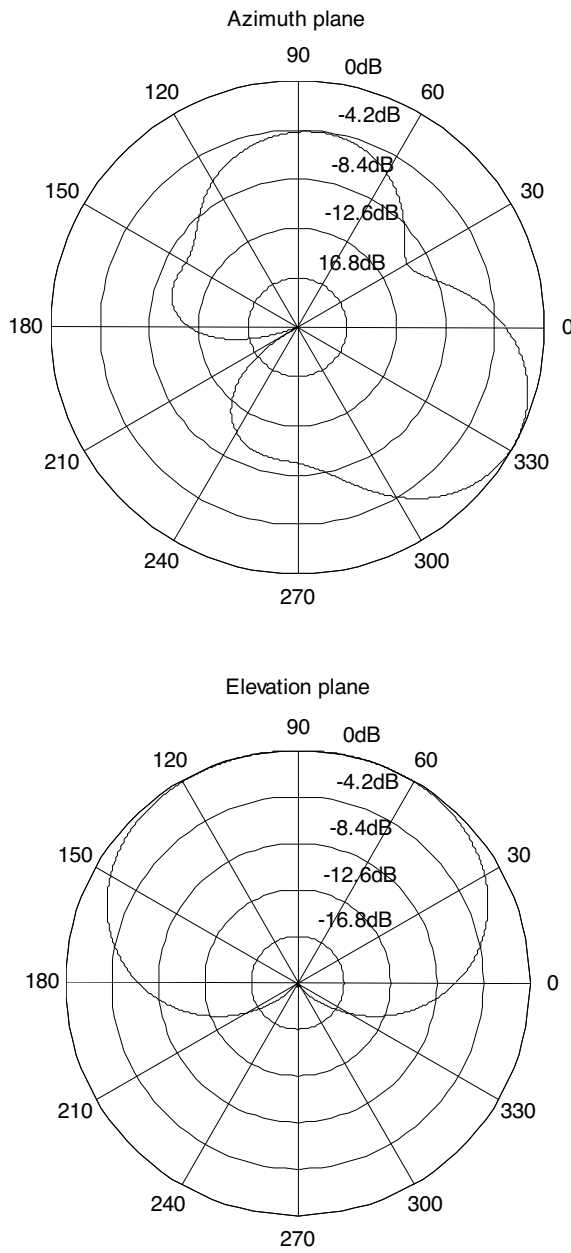

Figure 2f. Normalized radiation patterns no. 6 (in dB) in the azimuth and elevation plane of the 7-dipole planar array [7].

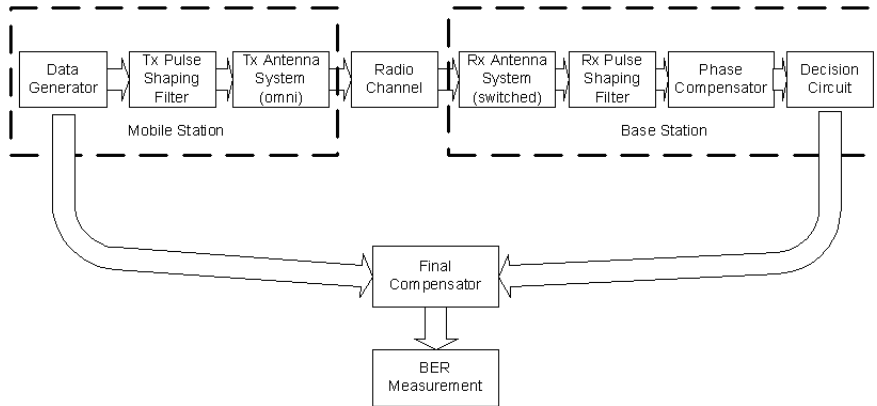

Figure 3. System model under investigation.

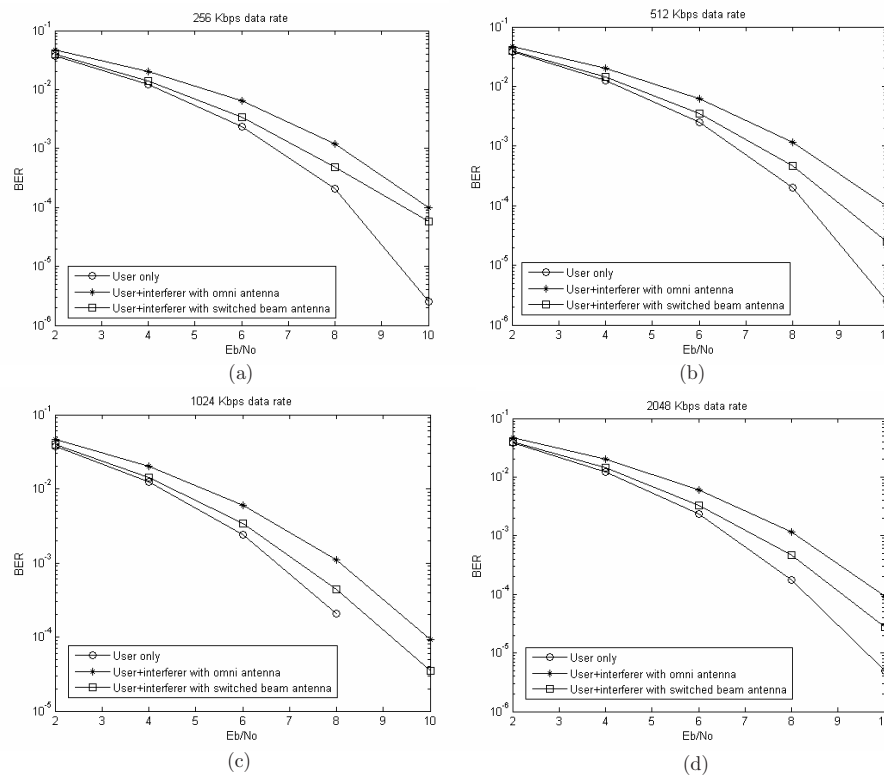

Figure 4. Bit Error Rate measurement with switched parasitic planar array and omni directional antenna system in an AWGN channel.

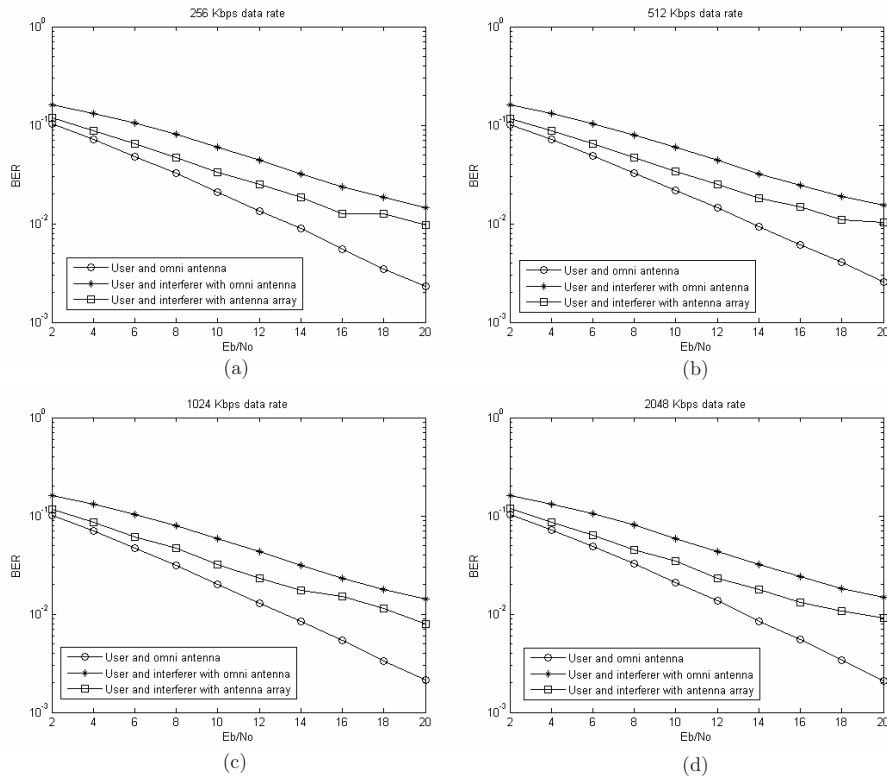

Figure 5. Bit Error Rate measurement with six-sector switched parasitic planar array and omni directional antenna system in a one path Rayleigh channel with AWGN.

according to the following rule: the training sequence bit stream received by all six-antenna patterns is correlated with the already known training sequence of the user. The setting that gives the maximum correlation is chosen.

4. SIMULATION RESULTS

The antenna array performance is tested under two different propagation scenarios: 1) in an AWGN channel and 2) in a one-path Rayleigh flat fading environment with AWGN. It should be noted that the equivalent low pass system was considered for the two above sets of radio channel environments. Concerning the simulation in the AWGN channel, the base station picks up only 20% of the interferer radiated

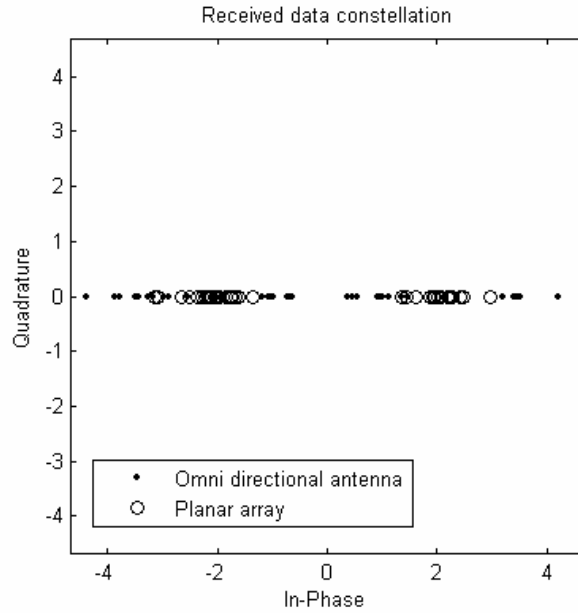

Figure 6. Received data constellation when an omni directional antenna and planar array is used.

power. Thus, the impact on the user of interest data is simulated to be low. Figure 4 illustrates the BER performance of the antenna system in terms of the user of interest E_b/N_0 for data rates from 256 Kbps up to 2 Mbps. It is clear that the obtained BER is drastically reduced for E_b/N_0 values ranging from 2 dB up to 6 dB. In that range, BER is slightly higher than that occurring in the absence of an interfering signal. For E_b/N_0 ratio equal or greater than 8 dB, the BER is more than twice as low as the one obtained in the case of the omni directional antenna.

A similar performance can be noticed in the one path Rayleigh flat fading environment with AWGN present, as shown in Figure 5. In that latter case, the base station picks up 60% of the interfering radiated power. A more complex scenario was chosen this time in order to evaluate the antenna system performance in an environment with strong variations. The users are moving at a velocity simulated equal to 72 Km/h, while the transmitted frequency f_c is considered to be 2.4 GHz. The latter factors lead to a Doppler frequency f_D equal to 160 Hz. Once again, the BER is reduced up to 50% providing a improved performance to the telecommunication system. Furthermore,

when comparing the required E_b/N_0 for a certain BER value, one can easily notice that there is approximately a 4 dB improvement. This is important since a 4 dB extra gain can be incorporated in the power budget between the mobile and base station.

Figure 6 illustrates the received data constellation, for E_b/N_0 equal to 4 dB and data rate 2048 kbps, when an omni directional and planar array is considered. It is clear that the received data in the case of the array, are less scattered around the decision values.

From Figures 4 to 6 it can be concluded that the receiver of a base station equipped with the proposed antenna array can operate efficiently with a sensitivity threshold level better than that when a conventional antenna is used, by a constant value over the whole E_b/N_0 range.

Our simulation results suggest that the error rate experienced during the communication of a mobile user with the base station is reduced. The implementation of a planar switched parasitic array provides an extra gain depending on the propagation channel. The angle discrimination achieved by the antenna system deteriorates any incoming interfering signals, resulting in a better error ratio.

5. CONCLUSIONS

In this paper a modified version of a six-beam switched parasitic planar array structure is proposed in order to mitigate interference effects. The main characteristics of the antenna patterns are selected according to the telecommunication network needs and the design of the antenna configuration is utilized with the aid of a genetic algorithm. By adding a low complexity DSP controller, it is proven that the performance of a telecommunication system, whose base stations are equipped with the proposed antenna array, can be improved.

The switched beam parasitic array provides a substantial spatial separation for desired and undesired signals, discarding interfering signals in an AWGN or one-path Rayleigh flat fading environment. Furthermore, when compared to a conventional omni directional antenna, it presents better BER performance that can be reduced up to 50%. Replacement of conventional omni directional antennas with the proposed system may optimize the communication system characteristics.

REFERENCES

1. Lozano, A., F. R. Farrokhi, and R. A. Valenzuela, "Lifting the limits on high-speed wireless data access using antenna arrays,"

- Communications Magazine*, Vol. 39, Issue 9, 156–162, September 2001.
2. Lehne, P. H. and M. Pettersen, “An overview of smart antenna technology for mobile communication systems,” *IEEE Communications Surveys*, Vol. 2, No. 4, 2–13, Fourth Quarter, 1999.
 3. Liberti, J. C. and T. S. Rappaport, *Smart Antennas for Wireless Communication: IS-95 and Third Generation CDMA Applications*, Prentice Hall, 1999.
 4. Balanis, C. A., *Antenna Theory Analysis and Design*, 3rd edition, John Wiley and Sons, 2005.
 5. Varlamos, P. K. and C. N. Capsalis, “Electronic beam steering using switched parasitic smart antenna arrays,” *Progress in Electromagnetics Research*, PIER 36, 101–109, 2002.
 6. Mitilineos, S. A., C. A. Papagianni, G. I. Verikaki, and C. N. Capsalis, “Design of switched beam planar arrays using the method of genetic algorithms,” *Progress in Electromagnetics Research*, PIER 46, 105–126, 2004.
 7. Varlamos, P. K. and C. N. Capsalis, “Design of a six-sector switched parasitic planar array using the method of genetic algorithms,” *Wireless Personal Communications*, Vol. 26, No. 1, 77–88, August 2003.