

A NOVEL DESIGN OF DUAL CIRCULARLY POLARIZED ANTENNA FED BY L-STRIP

G.-L. Wu, W. Mu, G. Zhao, and Y.-C. Jiao

National Laboratory of Antennas and Microwave Technology
Xidian University
Xi'an, Shaanxi 710071, P. R. China

Abstract—A novel design of dual circularly polarized antenna is proposed. By etching cross slots on the patch, circular polarization (CP) is achieved. The patch is fed by two L-strips which provide wide impedance bandwidth and high isolation level. Polarization diversity between left-hand circular polarization (LHCP) and right-hand circular polarization (RHCP) is provided by switching the two ports and both LHCP and RHCP signals can be received simultaneously. The experimental results show that the 3 dB axial ratio CP bandwidth of the proposed design is increased two times, as compared to a referential CP antenna fed by L-strip. The details of experimental results for the proposed design are presented and discussed.

1. INTRODUCTION

In this modern age of mobile communication and radio-frequency identification (RFID) systems, the need to develop multiband, low-profile, lightweight, and low-cost antennas has accordingly increased. Microstrip antennas have been studied extensively because of their advantages [1–4]. But the bandwidth of microstrip antenna is narrow. To overcome this disadvantage, antennas fed by L-strip [5] are developed. In [6], a single circularly polarized patch antenna fed by L-strip with wide impedance bandwidth is provided. However, the antenna can not realize dual polarization which is widely used in polarization diversity [7]. Reconfigurable patch antennas [8–12], offering polarization diversity, have been paid much attention to realize dual circularly polarization [13–16]. In spite of that, this type of antennas may hardly receive LHCP and RHCP signals simultaneously. In this paper, a novel design of dual circularly polarized antenna which is fed by L-strip is proposed. As shown in measured results, the

proposed antenna can achieve an impedance bandwidth of 9% at port 1 (for $S_{11} < -10$ dB) and 10% at port 2 (for $S_{22} < -10$ dB). In addition, an axial ratio bandwidth of 4.8% (for axial ratio < 3 dB) is obtained. Thus, the antenna can cover the RFID frequency band from 2.4 GHz to 2.485 GHz. Moreover, in the whole band, the isolation (S_{21}) between these two ports is better than -15 dB, which ensure the LHCP and RHCP signals be received simultaneously and the proposed antenna can also be used in polarization diversity systems

2. ANTENNA DESIGN

The geometry of the proposed dual circularly polarised antenna along with its parameters is shown in Fig. 1. The circular patch is printed on a square substrate with a thickness of 1mm and a dielectric constant of 2.65. The patch supported by a foam layer with dielectric constant equals to unity has a diameter of 38mm which is the same as the side length of the square substrate. The longer slot with length 37 mm and the shorter slot with length 4 mm, cross orthogonally at the center of each slot which is the center of the circular patch. Both slots are 3 mm in width and the resonant frequency is determined by slot lengths. As the feeds of the patch, two L-strips are attached to the end of two 50 microstrip lines (2.8 mm in width, 20 mm in length) respectively, which are formed by a substrate with dielectric constant 2.65 and thickness 1mm. Lengths of the vertical and horizontal portions of each L-strip are 18.5 mm and 9.5 mm respectively, and their widths are all 2.8 mm. The distance between the patch and the horizontal section of each L-strip in x -axis or y -axis direction is $d = 0.5$ mm, and the vertical section of each L-strip in z -axis direction is $s = 3.5$ mm. By adjusting s and d , good performance for both return loss and isolation can be achieved. The square ground plane has the same dimensions as the substrate, whose four side lengths are all 100 mm.

3. EXPERIMENTAL RESULTS AND DISCUSSION

The prototype of the proposed antenna with optimal geometrical parameters as shown in Fig. 1 was constructed and tested. The performance of this antenna was simulated with the aid of high frequency structure simulator (HFSS). The measurement was made with a Wiltron 37269A network analyzer. The measured results of return loss at port 1 and port 2 and the isolation between these two ports are shown in Fig. 2. It can be seen that the antenna can be operated from 2.41 to 2.63 GHz at port 1, which corresponds to an impedance bandwidth of 8.7% (for $S_{11} < -10$ dB) and the measured

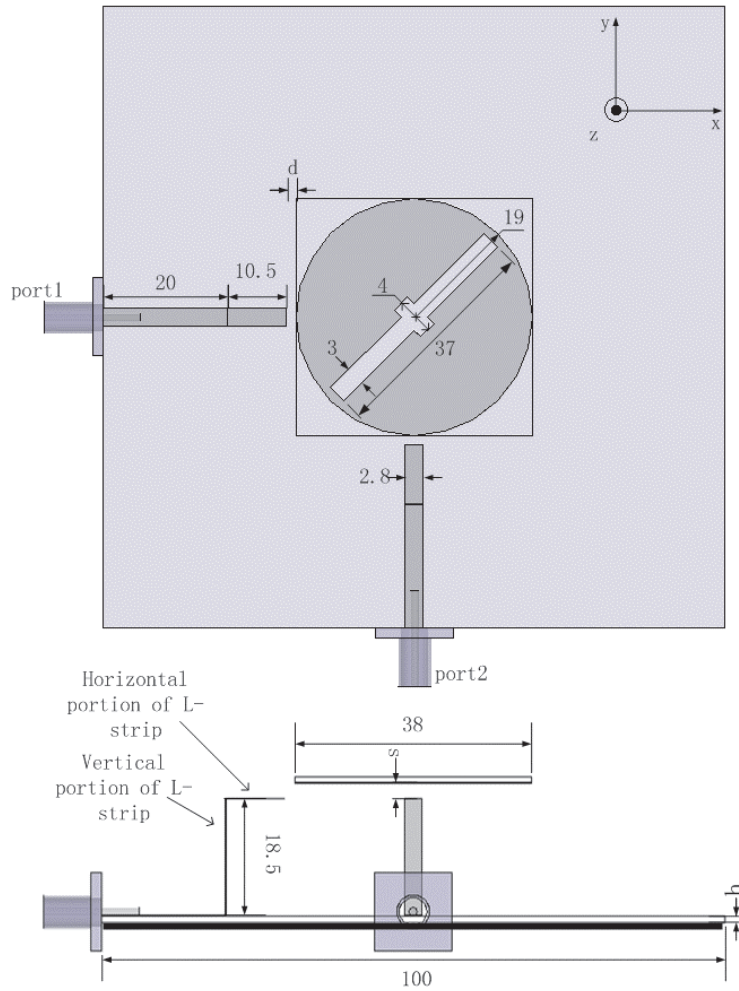

Figure 1. Geometry and dimensions of the proposed antenna (in mm), $s = 3.5$ mm, $d = 0.5$ mm.

return loss achieves a bandwidth of 9.9% (for $S_{22} < -10$ dB) from 2.4 to 2.65 GHz at port 2 with respect to their center frequency, respectively. Throughout the frequency range from 2.19 to 2.51 GHz, the isolation is better than 15 dB. Fig. 3 and Fig. 4 show the effect of the varying horizontally strip length $d = -1, 0.5, 2,$ and 3 mm with a fixed s of 3.5 mm on the impedance matching and isolation between two ports of the proposed antenna. It is found that, when the distance d , which is

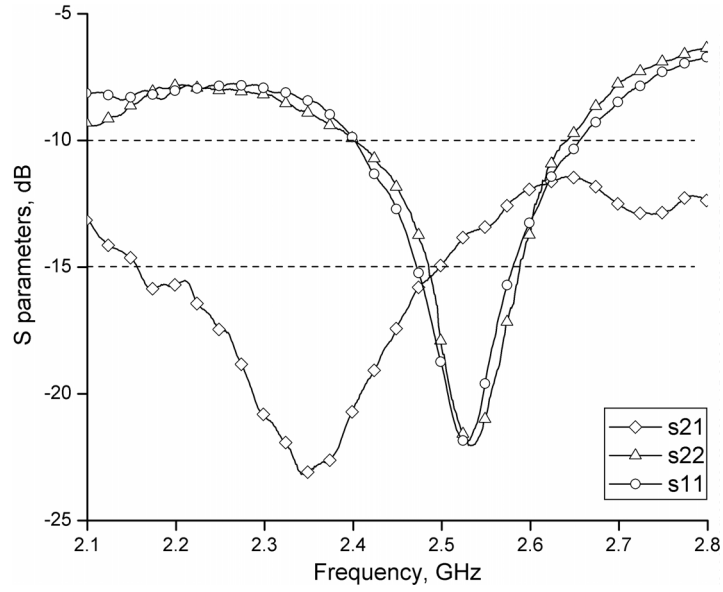

Figure 2. Measured return loss and isolation versus frequency for the proposed antenna studied in Fig. 1.

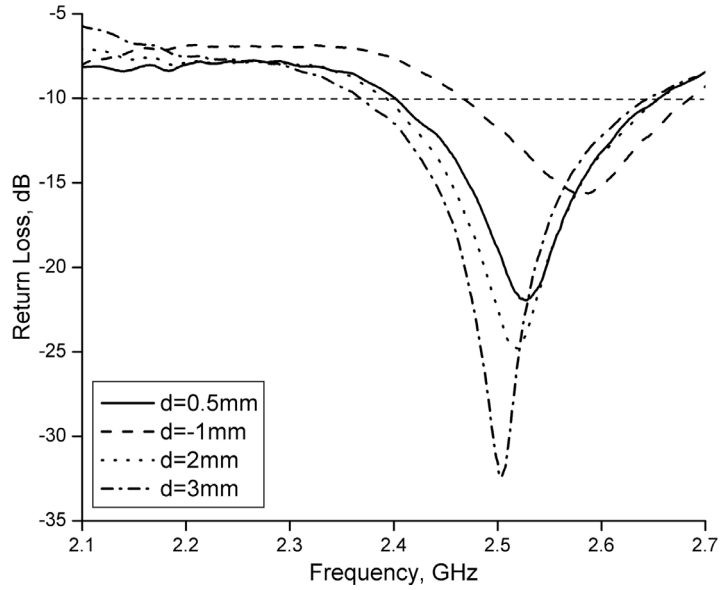

Figure 3. Measured return loss versus frequency for the proposed antenna with various d 's (other parameters are the same as in Fig. 1).

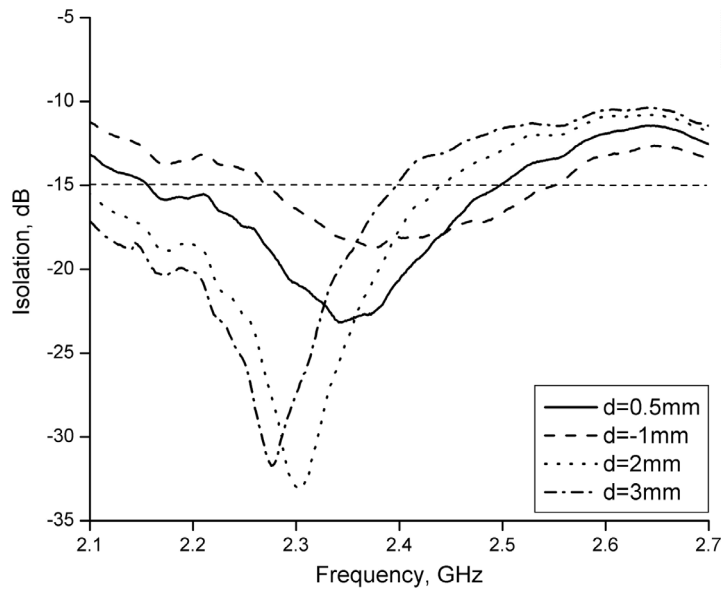

Figure 4. Measured isolation versus frequency for the proposed antenna with various d 's (other parameters are the same as in Fig. 1).

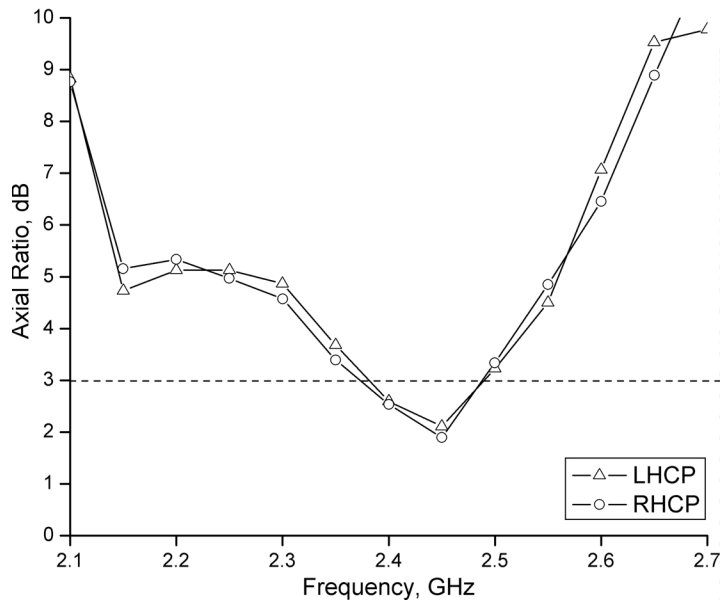

Figure 5. Measured axial ratio versus frequency for the proposed antenna studied in Fig. 1.

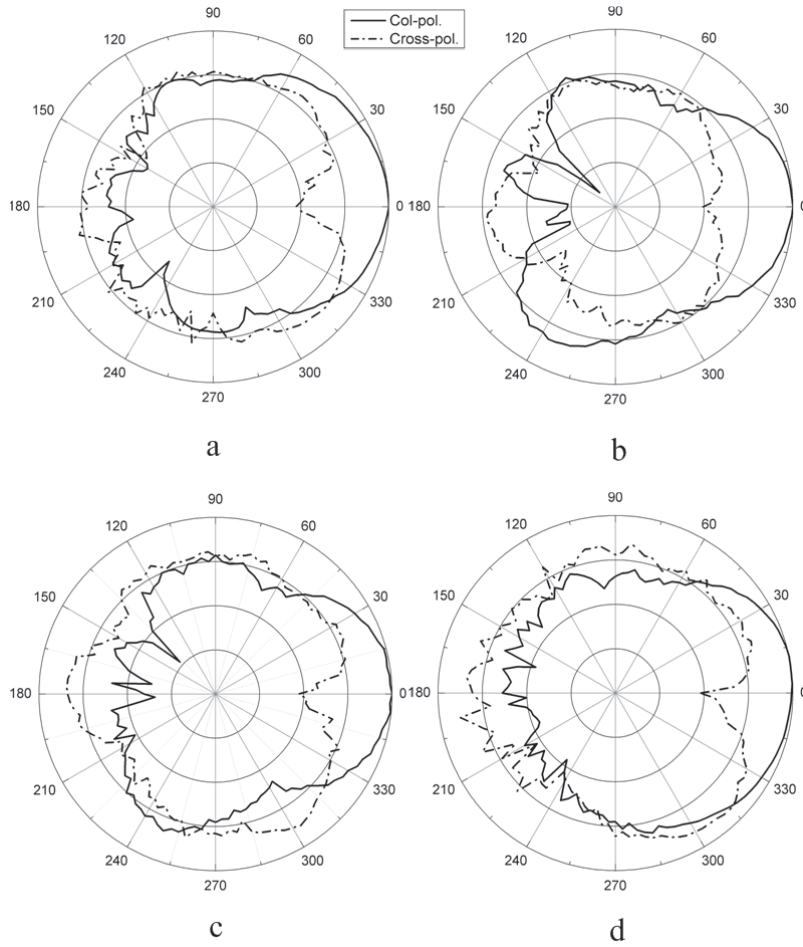

Figure 6. Measured radiation patterns for the proposed antenna studied in Fig. 1. Port 1 is excited: (a) x - z plane, (b) y - z plane. Port 2 is excited: (c) x - z plane, (d) y - z plane.

the horizontal portion of the L-strip into the circular patch, decreases, the impedance matching and the isolation between these two ports become better, however the return loss band and the isolation band does not coincide with each other. Similarly, when the distance s , which is the vertical portion of L-strip away from the circular patch, increases from 0.5 mm to 4 mm with a fixed d of 0.5 mm, the isolation become better, but the return loss band moves to high frequency. Fig. 5 shows the measured curve of the axial ratio of the antenna. From the

obtained results, it is clearly seen that the measured LHCP bandwidth, determined from 3 dB axial ratio, is 4.8% (118 MHz) with respect to the centre frequency 2.45 GHz. Both impedance matching (referred to 10 dB return loss) and low coupling level (referred to 15 dB isolation) are also achieved within the CP operating band.

The radiation characteristics are investigated. Fig. 6 presents the measured far-field radiation patterns of both co-polarization and cross-polarization for the designed antenna at resonant frequency 2.45 GHz. The measured peak gain is about 3.8 dBi for LHCP radiation and 3.6 dBi for RHCP radiation.

4. CONCLUSION

A novel design of dual circularly polarized antenna fed by L-strip for RFID is proposed and experimentally studied. By adjusting the length of the vertical and horizontal portions of the L-strip, an optimal performance in terms of impedance bandwidth, isolation level and axial ratio bandwidth is achieved. The measured return loss exhibits an impedance bandwidth of about 10% and the isolation between two polarization ports is better than 15 dB over the band. Results of radiation patterns and axial ratio are presented and discussed. Both ports can operate simultaneously and the antenna is suitable for RFID systems.

REFERENCES

1. Thakur, J. P. and J.-S. Park, "Frequency variable dual bands microstrip antenna design," *Microwave Opt. Technol. Lett.*, Vol. 48, 1199–1200, 2006.
2. Jan, J.-Y. and K.-L. Wong, "A dual-band circularly polarized stacked elliptic microstrip antenna," *Microwave Opt. Technol. Lett.*, Vol. 24, 354–357, 2000.
3. Abdelaziz, A. A., "Bandwidth enhancement of microstrip antenna," *Progress In Electromagnetics Research*, PIER 63, 311–317, 2006.
4. Pirhadi, A., M. Hakkak, and F. Keshmiri, "Using electromagnetic bandgap superstrate to enhance the bandwidth of probe-FED microstrip antenna," *Progress In Electromagnetics Research*, PIER 61, 215–230, 2006.
5. Luk, K. M., C. H. Lai, and K. F. Lee, "Wideband L-probe feed patch antenna with dual-band operation for GSM/PCS base stations," *Electron. Lett.*, Vol. 35, 1123–1124, 1999.

6. Cliau, W. K., C. H. Lo, and K. M. Luk, "Circularly polarized patch antenna array using proximity-coupled L-strip line feed," *Electron. Lett.*, Vol. 30, 1814–1815, 1994.
7. Tu, T.-C., C.-M. Li, and C.-C. Chiu, "The performance of polarization diversity schemes in outdoor micro cells," *Progress In Electromagnetics Research*, PIER 55, 175–188, 2005.
8. Shynu, S. V., G. Augustin, C. K. Aanandan, P. Mohanan, and K. Vasudevan, "Design of compact reconfigurable dual frequency microstrip antennas using varactor diodes," *Progress In Electromagnetics Research*, PIER 60, 197–205, 2006.
9. Chen, Y. B., Y. C. Jiao, and F. S. Zhang, "Polarization reconfigurable CPW-FED square slot antenna using pin diodes," *Microwave Opt. Technol. Lett.*, Vol. 49, 1233–1235, 2007.
10. Chen, Y.-B., T.-B. Chen, Y.-C. Jiao, and F.-S. Zhang, "A reconfigurable microstrip antenna with switchable polarization," *Journal of Electromagnetic Waves and Applications*, Vol. 20, No. 10, 1391–1398, 2006.
11. Chung, K., Y. Nam, T. Yun, and J. Choi, "Reconfigurable microstrip patch antenna with frequency and polarization diversity functions," *Microwave Opt. Technol. Lett.*, Vol. 47, 96–98, 2002.
12. Yang, F. and Y. Rahmat-Samii, "A reconfigurable patch antenna using switchable slots for circular polarization diversity," *IEEE Microwave Wireless Compon. Lett.*, Vol. 12, 96–98, 2002.
13. Aloni, E. and R. Kastner, "Analysis of a dual circularly polarized microstrip antenna fed by crossed slots," *IEEE Trans. Antennas Propagat.*, Vol. 42, 186, 1994.
14. Zhang, M.-T., Y.-B. Chen, Y.-C. Jiao, and F.-S. Zhang, "Dual circularly polarized antenna of compact structure for RFID application," *Journal of Electromagnetic Waves and Applications*, Vol. 20, No. 14, 1895–190, 2006.
15. Bao, X. L. and M. J. Ammann, "Comparison of several novel annular-ring microstrip path antennas for circular polarization," *Journal of Electromagnetic Waves and Applications*, Vol. 20, No. 11, 1, 1427–1438, 2006.
16. Liu, W. C. and P.-C. Kao, "Design of a probe-fed H-shaped microstrip antenna for circular polarization," *Journal of Electromagnetic Waves and Applications*, Vol. 21, No. 7, 857–864, 2006.