

## **AN OVERVIEW ON DEFECTED GROUND STRUCTURE**

**L. H. Weng, Y. C. Guo, X. W. Shi, and X. Q. Chen**

National Key Laboratory of Antenna and Microwave Technology  
Xidian University  
NO. 2 South Taibai Road, Xi'an, Shaanxi, P. R. China

**Abstract**—This paper focuses on a tutorial overview of defected ground structure (DGS). The basic conceptions and transmission characteristics of DGS are introduced and the equivalent circuit models of varieties of DGS units are also presented. Finally, the main applications of DGS in microwave technology field are summarized and the evolution trend of DGS is given.

### **1. INTRODUCTION**

High performance, compact size and low cost often meet the stringent requirements of modern microwave communication systems. There have been some new technologies such as Low-temperature co-fire ceramic technology (LTCC), Low-temperature co-fire ferrite (LTCCF) and some new structures such as Photonic band gap (PBG), DGS, Substrate integrate wave-guide (SIW) and so on to enhance the whole quality of system. In 1987, Yablonovitch and John proposed PBG [1, 2] which implodes and utilizes metallic ground plane, and breaks traditional microwave circuit confined design to surface components and distributions of the medium circuit plane. Consequently, there has been an increasing interest in microwave and millimeter-wave applications of PBG [3–7]. Similarly, there is another new ground plane aperture (GPA) technique which simply incorporates the microstrip line with a centered slot at the ground plane, and the use of GPA has attractive applications in 3 dB edge coupler for tight coupling and band pass filters for spurious band suppression and enhanced coupling [8, 9, 10].

PBG is a periodic structure which has been known as providing rejection of certain frequency band. However, it is difficult to use a PBG structure for the design of the microwave or millimeter-wave

components due to the difficulties of modeling. There are so many design parameters that effect on the band gap property, such as the number of lattice, lattice shapes, lattice spacing and relative volume fraction. Another problem is caused by the radiation from the periodic etched defects. Furthermore, with the introduction of a GPA below the strip, the line properties could be changed significantly as the characteristic impedance varies with the width of the GPA. Usually the GPA is considered as the basis of equivalent J-inverter circuit theory and its filtering behavior has been characterized by a closed-form equation. As a technique to improve circuit performance, there is more investigations on the applications than the essence of GPA. In order to alleviate these problems Park et al. [11] proposed DGS which is designed by connecting two square PBG cells with a thin slot. DGS which bases on GPA focuses not only on its application but also on its own characteristics. DGS adds an extra degree of freedom in microwave circuit design and opens the door to a wide range of application. In the following years, a great lot of novel DGSs were proposed and they had become one of the most interesting areas of research owing to their extensive applicability in microwave circuits. The parameters of equivalent circuits models of DGSs were also researched and utilized to design planar circuit easily. Many passive and active microwave and millimeter devices have been developed to suppress the harmonics and realize the compact physical dimensions of circuits for the design flow of circuits with DGS comparatively simple.

In this paper, a tutorial overview of DGS is present. The basic conception and transmission characteristics of DGS units are introduced and the equivalent circuit models of varieties of DGS units are also presented. Finally, the main applications of DGS in microwave technology field are summarized and the evolution trend of DGS is given.

## 2. DEFECTED GROUND STRUCTURE

DGS is an etched periodic or non-periodic cascaded configuration defect in ground of a planar transmission line (e.g., microstrip, coplanar and conductor backed coplanar wave guide) which disturbs the shield current distribution in the ground plane cause of the defect in the ground. This disturbance will change characteristics of a transmission line such as line capacitance and inductance. In a word, any defect etched in the ground plane of the microstrip can give rise to increasing effective capacitance and inductance.

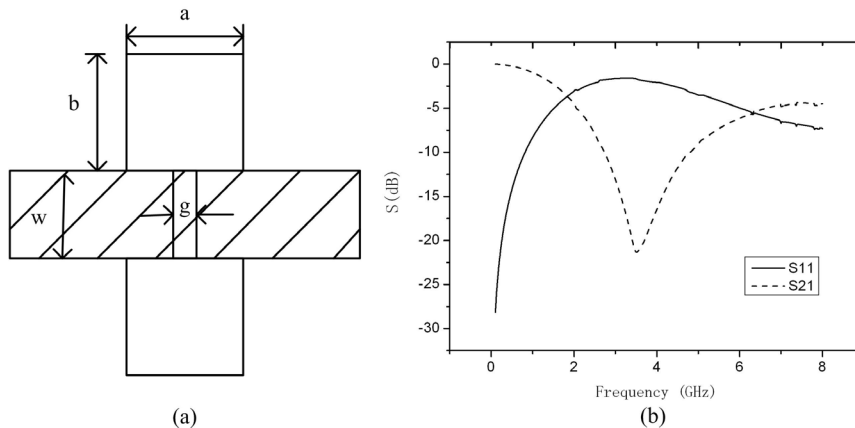

**Figure 1.** The first DGS unit: (a) Dumbbell DGS unit, (b) Simulated  $S$ -parameters for dumbbell DGS unit.

### 2.1. Basic Structure and Transmission Characteristics

The dumbbell DGS are composed of two  $a \times b$  rectangular defected areas,  $g \times w$  gaps and a narrow connecting slot wide etched areas in backside metallic ground plane as shown in Fig. 1(a). This is the first DGS [11]. Fig. 1(b) shows the  $S$ -parameters from an EM simulation of a dumbbell DGS. DGSs have the characteristics of stopband, slow-wave effect and high impedance. DGS has more advantages than PBG as follows: (1) The circuit area becomes relatively small without periodic structures because only a few DGS elements have the similar typical properties as the periodic structure like the stop-band characteristic. (2) The simulated  $S$ -parameters for dumbbell DGS unit can be matched to the one-pole Butterworth-type low-pass response. For the DGS unit, DGS pattern is simply fabricated and its equivalent circuit is easily extracted. (3) DGS needs less circuit sizes for only a unit or a few periodic structures showing slow-wave effect. Compared with PBG, DGS is more easily to be designed and implemented and has higher precision with regular defect structures. Therefore, it is very extensive to extend its practical application to microwave circuits. DGS has more competition than PBG in the microwave circuit with high requirement of dimension under certain craftwork conditions.

### 2.2. DGS Unit

There have been two research aspects for adequately utilizing the unique performance of DGS: DGS unit and periodic DGS. A variety of

slot geometries etched in the microstrip line ground plane have been reported in the literature [12–16]. In Fig. 2, it is shown that a variety of attached area shapes including spiral head, arrowhead-slot and “H” shape slots and so on. There also have been more complex DGSs so as to improve the circuit performance shown in Fig. 2, such as: a square open-loop with a slot in middle section, open-loop dumbbell and interdigital DGS. The new DGS unit could control the two transmission zeros near the passband edges and easily control the frequency of the slot by changing the length of the metal fingers [17, 18].

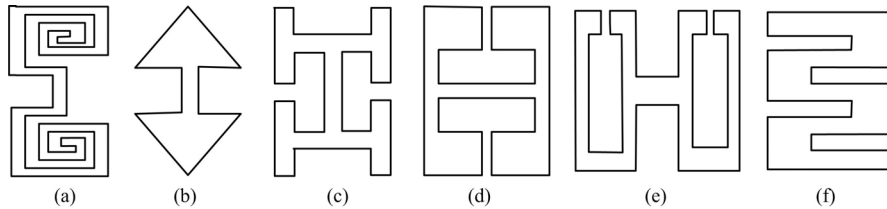

**Figure 2.** Various DGSs: (a) spiral head, (b) arrowhead-slot, (c) “H” shape slots, (d) a square open-loop with a slot in middle section, (e) open-loop dumbbell and (f) interdigital DGS.

The use of a bent microstrip line does not significantly change the frequency behavior that remains as for the straight DGS microstrip line. The bending technique leads to a 2D configuration, in which the microstrip line presents multiple bends, following a similar structure as that of a meander line. This configuration has a broad stopband and allows a large number of periods in a reasonable circuit area. New proposed DGS unit has some advantages than dumbbell DGS:

- (1) A higher slow wave factor and more compact circuit. The circuit area of filter using “H” shape slots is much smaller about 26.3% than using dumbbell DGS [19].
- (2) A narrow width stopband and deeper rejection.
- (3) A slightly larger external Q. To compare the transfer characteristics of the U-slot DGS with that of the conventional DGS, the spiral-shaped DGS and U-slot DGS are designed to provide the same resonance frequency. Q factor of the spiral DGS is 7.478 (3 dB bandwidth of 0.39 GHz), while the U-slot DGS provides a high-Q factor of 36.05 (3 dB bandwidth is 0.081 GHz) [20].

In a word, more and more new DGSs are proposed which bring a great convenience to the design of microwave circuit to realize various passive and active device compact structures and to suppress the harmonics.

### 2.3. Periodic DGS

Periodic structures such as PBG and DGS for planar transmission lines have drawn a wide interest for their extensive applicabilities in antennas and microwave circuits. Transmission lines with a periodic structure have a finite pass and rejection band as low-pass filters. The increased slow-wave effect and the additional equivalent components are important properties of periodic structure that can be realized and the circuit sizes can be reduced using these properties. Periodic means repetition of the physics structure. By cascading DGS resonant cells in the ground plane the depth and bandwidth of the stopband for the proposed DGS circuit are inclined to depend on the number of period. Period DGSs care about parameters including the shape of unit DGS, distance between two DGS units and the distribution of the different DGSs. As shown in Fig. 3, by now there are two types of periodic DGS: one is (a) horizontally periodic DGS(HPDGS), the other is (b)vertically periodic DGS(VPDGS) [21–23].

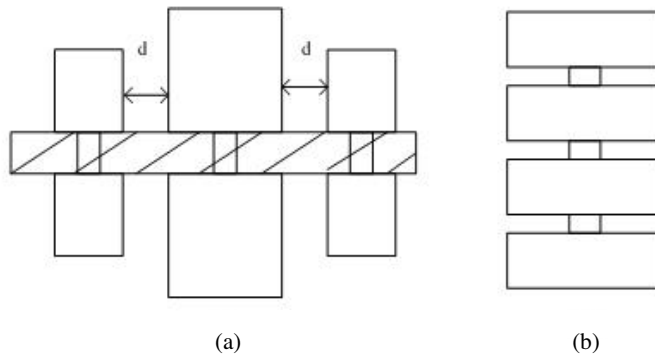

**Figure 3.** Periodic DGS: (a) HPDGS, (b) VPDGS.

The prominent feature of the proposed structure is possible to organize the periodicity along the vertical direction as well as the horizontal direction. It is named as VPDGS. On the other hand, the conventional DGS for planar transmission lines have the only HPDGS with serially cascading structure along the transmission direction. HPDGS initially is produced for enlarging the stopband of frequency response curve. Few uniform square-patterned defects form a periodic DGS for planar circuit, which provides excellent stopband and slow-wave characteristics. They have been reported and used in oscillators and amplifiers [23–26]. Nonuniform circular-patterned DGSs using the function distribution compared with the previous periodic DGSs are proposed. They have a compensated microstrip line and the

dimensions of the square defects are varied proportionally to relative amplitudes distribution of the exponential function  $e^{1/n}$  distribution ( $n$  denotes the positive integer), or Chebyshev,  $[\ln(10)]^{1/n}$  distribution,  $C^{1/n}$  distribution and so on. VPDGS produces much higher slow-wave factor than HPDGS. The increased slow-wave factor means the longer electrical length for the same physical length. As an application example, a size-reduced amplifier was designed by inserting VPDGS into the matching network. Two series microstrip lines in input and output matching networks of the amplifier were reduced to 38.5% and 44.4% of the original lengths, respectively [22].

### 3. EQUIVALENT CIRCUITS OF DGS

Design and analysis are two challenges for DGS. The commercially available EM solvers is the main resource to design and analyze DGS. To apply the proposed DGS section to a practical circuit design example, it is necessary to extract the equivalent circuit parameters. In order to derive the equivalent circuit parameters of DGS unit at the reference plane, the  $S$ -parameters vs. frequency should be calculated by full-wave electromagnetic (EM)-simulation to explain the cutoff and attenuation pole characteristics of the DGS section. The circuit parameters for the derived equivalent circuit can be extracted from the simulation result which can be fit for the one-pole Butterworth-type low-pass response. The full-wave analysis does not give any physical insight of the operating principle of DGS. The follow flow chart in Fig. 4 shows the conventional design and analysis methods of DGSs. The full-wave solver is used to find the  $S$ -parameters vs. frequency behavior of the DGS. The disadvantage of this method is that there is no direct correlation between the physical dimensions of DGS and the equivalent  $LC$  parameters. The derived performance of DGS is not fully predictable until the optimized solutions are achieved through trial and error iterative process. Hence the conventional methods as reported in the open literature [11, 27–31, 36] are time consuming and may not lead to optimum design.

At present, DGS can be equivalent by three types of equivalent circuits: (1)  $LC$  and  $RLC$  equivalent circuits, (2)  $\pi$  shaped equivalent circuit, (3) quasi-static equivalent circuit.

#### 3.1. $LC$ and $RLC$ Equivalent Circuits

The equivalent circuit of the DGS and one-pole Butterworth prototype of the LPF are given in Fig. 5. The rectangular parts of dumbbell DGS increase route length of current and the effective inductance.

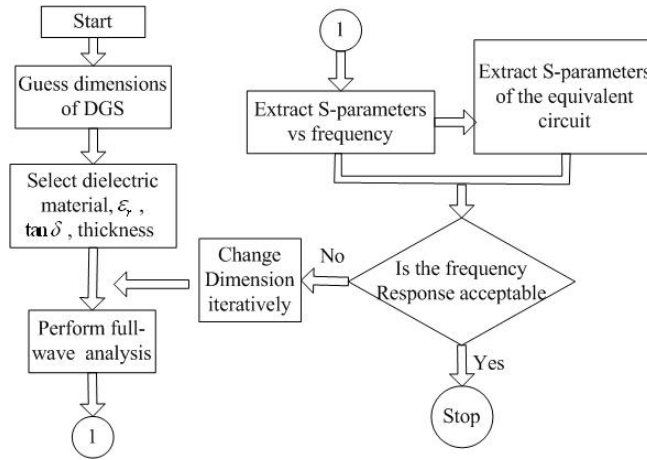

**Figure 4.** Conventional design and analysis method of dumbbell DGS.

The slot part accumulates charge and increases the effective capacitor of the microstrip line. Two rectangular defected areas and one connecting slot correspond to the equivalently added inductance ( $L$ ) and capacitance ( $C$ ), respectively. Accordingly, a resonance occurs at a certain frequency because of the parallel  $L$ - $C$  circuit. Inversely, it is intuitively known that the equivalent circuit includes a pair of parallel inductor-capacitor form the resonant phenomenon in the  $S$ -parameter. As the etched area of the unit lattice increases, the effective series inductance increase and increasing the series inductance gives rise to a lower cutoff frequency. When the etched gap distance increases, the effective capacitance decreases so that the attenuation pole location moves up to higher frequency.

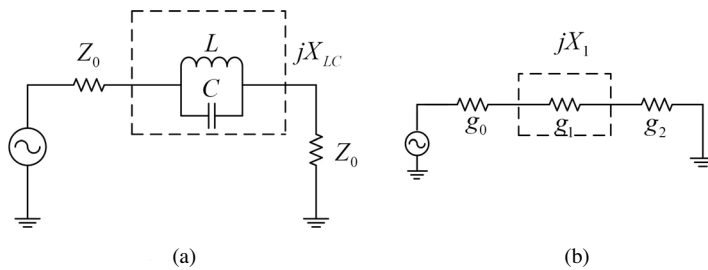

**Figure 5.**  $LC$  equivalent circuit: (a) equivalent circuit of the dumbbell DGS circuit, (b) Butterworth-type one-pole prototype low-pass filter circuit.

In order to match DGS to Butterworth low-pass filter reactance values of both circuits are equal at the cutoff frequency. So  $L$  and  $C$  are derived as follows:

$$X_{LC} = \frac{1}{\omega_0 C} \left( \frac{\omega_0}{\omega} - \frac{\omega}{\omega_0} \right) \quad (1)$$

where,  $\omega_0$  is the resonance angular frequency of the parallel  $LC$  resonator.

$$\begin{cases} C = \frac{\omega_c}{Z_0 g_1} \cdot \frac{1}{\omega_0^2 - \omega_c^2} \\ L = 1/4\pi^2 f_0^2 C \end{cases} \quad (2)$$

where  $f_0$  and  $f_c$  are resonance (attenuation pole) and cutoff frequency which can be obtained from EM simulation results. The characteristics of most of DGS are similar to dumbbell DGS, so they could be discussed by one-pole Butterworth low-pass filter too. Furthermore, radiation effects are more or less neglected. DGS unit can be modeled most efficiently by a parallel  $R$ ,  $L$ , and  $C$  resonant circuit connected to transmission lines at its both sides as shown in Fig. 6. This resistance corresponds to the radiation, conductor and dielectric losses in the defect. From EM simulations or measurements for a given DGS, the equivalent  $R$ ,  $L$ , and  $C$  values are obtained from the expression in [27].

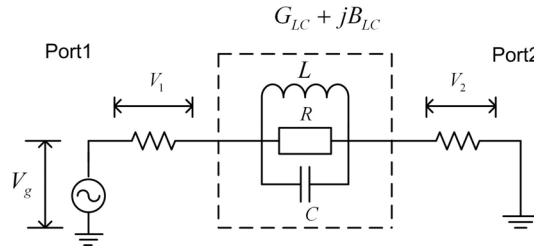

**Figure 6.**  $RLC$  equivalent circuit for unit DGS.

$$\begin{cases} C = \frac{\omega_c}{2Z_0 (\omega_0^2 - \omega_c^2)} \\ L = 1 / (4\pi^2 f_0^2 C) \\ R(\omega) = 2Z_0 / \sqrt{\frac{1}{|S_{11}(\omega)|^2} - \left( 2Z_0 \left( \omega C - \frac{1}{\omega L} \right) \right)^2 - 1} \end{cases} \quad (3)$$



The size of DGS is determined by accurate curve-fitting results for equivalent-circuit elements to correspond exactly to the required inductance.

### 3.2. $\pi$ Shaped Equivalent Circuits

However, it is very difficult to implement the DGS circuits for the purposed of the harmonic termination to satisfy simultaneously the excellent pass band and stop band characteristics. More accurate equivalent circuit models than the  $LC$  and  $RLC$  equivalent circuit were proposed, such as  $\pi$  shaped equivalent circuit shown in Fig. 7.

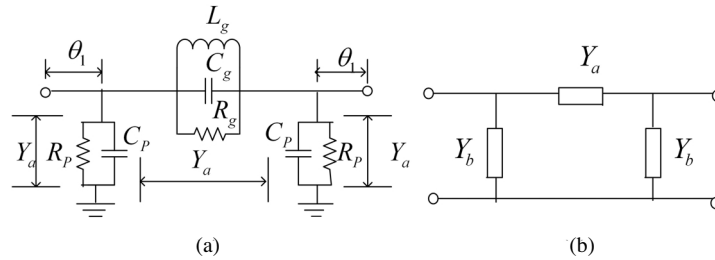

**Figure 7.**  $\pi$  shaped equivalent circuit for unit DGS: (a) equivalent circuit, (b)  $\pi$  shaped circuit.

Considered the phase influence of DGS, Park proposed  $\pi$  shaped equivalent which simulates both amplitude vs. frequency and phase vs. frequency characteristics. The  $S$ -parameters vs. frequency curve of  $\pi$  shaped equivalent is more anatomized than  $LC$  and  $RLC$  equivalents, but its circuit is more complex and the parameters is so many that the equivalent is difficult to extract.  $\pi$  shaped equivalent circuit is much suitable to the exigent precision of circuit design. The ABCD parameters for the unit cell will be obtained using the expression as follows:

$$\begin{bmatrix} A & B \\ C & D \end{bmatrix} = \begin{bmatrix} 1 + Y_b/Y_a & 1/Y_a \\ 2Y_b + Y_b^2/Y_a & 1 + Y_b/Y_a \end{bmatrix} \quad (4)$$

$$\begin{cases} Y_a = 1/R_g + jB_r \\ Y_b = 1/R_p + jB_p \\ C_g = \frac{B_r}{\omega_2 \left( \frac{\omega_1}{\omega_2} - \frac{\omega_2}{\omega_1} \right)}, L_g = \frac{1}{\omega_2^2 C_g}, C_p = \frac{B_p}{\omega_1} \end{cases} \quad (5)$$

The full-wave analysis is very involving and does not give any physical insight of the operating principle of the DGS.

### 3.3. Quasi-static Equivalent Circuit

Different from the two types of equivalent circuits mentioned above, a quasi-static equivalent circuit model of a dumbbell DGS is developed which is directly derived from the physical dimensions of dumbbell DGS is depicted in Fig. 8.

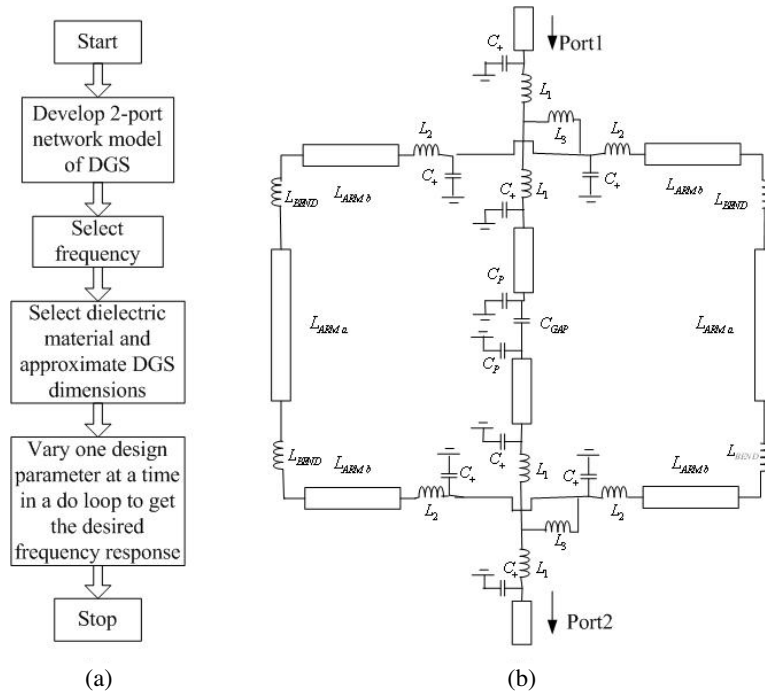

**Figure 8.** New design and analysis method of DGS: (a) analysis method of DGS, (b) equivalent-circuit model of unit cell DGS.

This overcomes the limitation of report full-wave analysis by developing the equivalent circuit model. This approach gives a comprehensive understanding of the physical principle of DGS including how the DGS creates bandstop and bandpass responses and which dimensions play the most vital role to create the distinct performance. At present, the equivalent circuits are mostly concerned about influences of the addition of DGS such as radiation, or an equivalent circuit corresponded to a new DGS. Because different DGS has different characteristic, different equivalent circuits are not formed uniform circuit model and mathematics theory for the moment. Thus, the optimization based on an equivalent circuit network is highly desirable to design and evolve this kind of circuit configuration.

#### 4. APPLICATION IN MICROWAVE CIRCUIT

There are widely applications in active and passive devices useful for compact design. Since each DGS provides its own distinctive characteristics depending on the geometries, such circuit functionalities as filtering unwanted signals and tuning high-order harmonics can easily be accomplished by means of placing required DGS patterns, which correspond to the desired circuit operations without increasing circuit complexity.

##### 4.1. Stopband Effects

DGS, which is realized by etching off a defected pattern or periodic structures from the backside metallic ground plane, has been known as providing rejection of certain frequency band, namely, bandgap effects. The stopband is useful to suppress the unwanted surface waves, spurious and leakage transmission. Therefore, a direct application of such frequency selective characteristics in microwave filters is becoming a hotspot research recently. As Fig. 9 shown, the Hilbert curve ring (HCR) DGS lowpass filter achieves a quite steep rejection property, a low in-band insertion loss less of below 0.5 dB and a high outband suppression of more than 33 dB in a wide frequency rang [33].

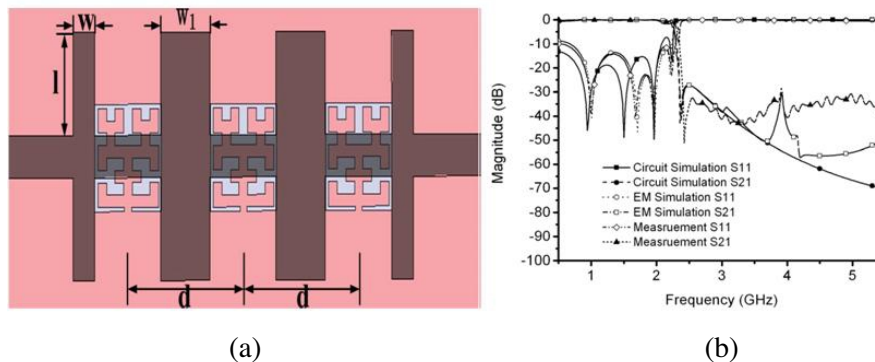

**Figure 9.** HCR DGS lowpass filter (a) layout of the HCR DGS lowpass filter (3-cell), (b) simulation and measurement results.

DGS provides excellent performances in terms of ripples in the passband, sharp-selectivity at the cut-off frequency and spurious free wide stopband. There have two types of filter design using DGS: one is directly using the frequency-selectivity characteristic of DGS to design filters [31–34], the other is using DGS on the conventional microstrip

filters so as to improve performance [35–39]. The second search concerns exploitation both on the conductor plane of the microstrip and the ground plane which is the most investigation hotspot in recent years. Several improvements are obtained using DGS in the metallic ground plane for the response of filter. These improvements summarize as follows: (1) More transition sharpness, (2) Suppressing higher harmonic, (3) Achieving broader stopband responses, (4) Improving the stopband and passband characteristics. Some DGS also tries to combine new material and new technology to design filters. For example, a filter is designed based on DGS and LTCC [40]. There also adopts SIW combined with the concept of DGS [41].

#### 4.2. Slow-Wave Effect

One of the most important advantages of DGS is the slow-wave effect which is caused by the equivalent  $LC$  components. The transmission lines with DGS have much higher impedance and increased slow-wave factor than conventional lines. So the circuit size can be reduced with these properties, such as microwave amplifiers and Rat-race hybrid couplers [42]. Furthermore, DGS could be used in broadband couplers. In Fig. 10, DGS Doherty power amplifier (DDA) could reduce the circuit size effectively by the negligible insertion loss, excellent harmonic termination characteristic and slow-wave effect [43]. Compared with the conventional Doherty power amplifier (CDA), the radii of the reduced lengths to CDA are 71% at the carrier amplifier output and 62% at the peaking amplifier output. Another attractive application of the DGSs is in the beam steering of a phased array antenna. DGS also can improve the performance of the antenna, restrain harmonious and reduce the mutual coupling of antenna array by suppressing the surface waves [44, 45].

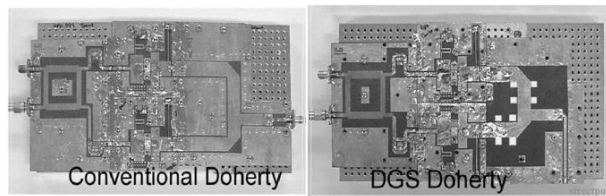

**Figure 10.** Comparison of the whole circuit size of CDA and DDA.

#### 4.3. High Characteristic Impedance

It is a serious problem for conventional microstrip line case that the generally accepted impedance is limited to realize is around  $100 \sim$

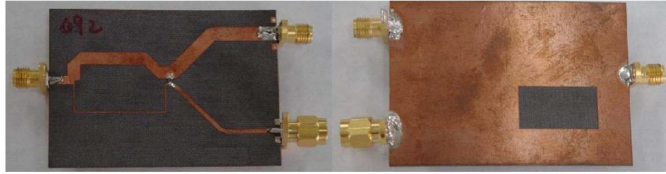

**Figure 11.** Photo of the fabricated 1:6 Wilkinson divider with DGS.

130  $\Omega$ . By adopting DGS on the ground plane is possible to increase the equivalent inductance  $L$  highly, and to decrease the equivalent  $C$  at the same time, and finally to raise the impedance of the microstrip line more than 200  $\Omega$ . For example, Fig. 11 shows layout of the proposed 1:6 unequal Wilkinson power divider that has been designed adopting DGS and a microstrip line with 208  $\Omega$  of characteristic impedance has been realized using a simple rectangular-shaped DGS [46]. The high characteristic impedance of DGS may also be used in digital systems (interconnects).

## 5. CONCLUSIONS

In this paper, the evolutions of DGS from conventional PBGs are reported. The basic conceptions and transmission characteristics of DGS are introduced and the equivalent circuit models of varieties of DGS units are also presented. DGS has simple structure, equivalent  $LC$  circuit model, and potentially great applicability to design RF circuit. Various designs in HMIC and MMIC have been investigated to yield better performance in terms of passband width, ripple free transmission and wider stopband.

## REFERENCES

1. John, S., "Strong localization of photons in certain disordered dielectric superlattices," *Physical Review Letters*, Vol. 58, No. 23, 2486–2489, 1987.
2. Yablonovitch, E., "Inhibited spontaneous emission in solid-state physics and electronics," *Physical Review Letters*, Vol. 58, No. 20, 2059–2062, 1987.
3. Tarot, A. C., S. Collardey, and K. Mahdjoubi, "Numerical studies of metallic pbg structures," *Progress In Electromagnetics Research*, PIER 41, 133–157, 2003.
4. Guida, G., A. de Lustrac, and A. Priou, "An introduction to pho-

- tonic band gap (PBG) materials,” *Progress In Electromagnetics Research*, PIER 41, 1–20, 2003.
5. Zheng, L. G. and W. X. Zhang, “Analysis of bi-anisotropic pbg structure using plane wave expansion method,” *Progress Electromagnetics In Research*, PIER 42, 233–246, 2003.
  6. Zheng, L. G. and W. X. Zhang, “Study on bandwidth of 2-d dielectric PBG material,” *Progress In Electromagnetics Research*, PIER 41, 83–106, 2003.
  7. Yuan, H. W., S.-X. Gong, X. Wang, and W.-T. Wang, “Scattering analysis of a printed dipole antenna using PBG structures,” *Progress In Electromagnetics Research B*, Vol. 1, 189–195, 2008.
  8. Daeyoung, O. and P. Ikmo, “Two-arm microstrip spiral antenna with a circular aperture on the ground plane for generating a circularly polarized conical beam,” *IEEE Antennas Propag. Soc. Int. Symp.*, Vol. 3, 866–869, 2003.
  9. Velazquez-Ahumada, M. C., J. Martel, and F. Medina, “Parallel coupled microstrip filters with ground-plane aperture for spurious band suppression and enhanced coupling,” *IEEE Trans. Microwave Theory Tech.*, Vol. 52, 1082–1086, 2004.
  10. Sharma, R., T. Chakravarty, S. Bhooshan, et al., “Characteristic impedance of a microstrip-like interconnect line in presence of ground plane aperture,” *International Journal of Microwave Science and Technology*, Vol. 1, 1–5, 2007.
  11. Park, J.-I., C.-S. Kim, et al., “Modeling of a photonic bandgap and its application for the low-pass filter design,” *Asia Pacific Microwave Conf. Proc. APMC*, Vol. 2, 331–334, 1999.
  12. Lim, J.-S., C.-S. Kim, Y.-T. Lee, et al., “A spiral-shaped defected ground structure for coplanar waveguide,” *IEEE Microwave Compon. Lett.*, Vol. 12, No. 9, 330–332, 2002.
  13. Boutejdar, A., G. Nadim, S. Amari, et al., “Control of bandstop response of cascaded microstrip low-pass-bandstop filters using arrowhead slots in backside metallic ground plane,” *IEEE Antennas Propag. Soc. Int. Symp.*, Vol. 1B, 574–577, 2005.
  14. Chen, H.-J., T.-H. Huang, C.-S. Chang, et al., “A novel cross-shape DGS applied to design ultra-wide stopband low-pass filters,” *IEEE Microwave Compon. Lett.*, Vol. 16, No. 5, 252–254, 2006.
  15. Li, J. L., J. X. Chen, Q. Xue, et al., “Compact microstrip lowpass filter based on defected ground structure and compensated microstrip line,” *IEEE MTT-S Int. Microwave Symp. Digest*, 1483–1486, 2005.
  16. Chen, J. X., J. L. Li, K. C. Wan, et al., “Compact quasi-elliptic

- function filter based on defected ground structure,” *IEE Proc. Microwaves Antennas Propag.*, Vol. 153, No. 4, 320–324, 2006.
17. Liu, H., Z. Li, and X. Sun, “Compact defected ground structure in microstrip technology,” *Electron. Lett.*, Vol. 41, No. 3, 132–134, 2005.
  18. Ting, S.-W., K.-W. Tam, and R. P. Martins, “Compact microstrip quasi-elliptic bandpass filter using open-loop dumbbell shaped defected ground structure,” *IEEE MTT-S Int. Microwave Symp. Digest*, 527–530, 2006.
  19. Mandal, M. K. and S. Sanyal, “A novel defected ground structure for planar circuits,” *IEEE Microwave Compon. Lett.*, Vol. 16, No. 2, 93–95, 2006.
  20. Woo, D.-J., T.-K. Lee, J.-W. Lee, et al., “Novel u-slot and v-slot dgs for bandstop filter with improved Q factor,” *IEEE Trans. Microwave Theory Tech.*, Vol. 54, No. 6, 2840–2846, 2006.
  21. Lim, J.-S., Y.-T. Lee, C.-S. Kim, et al., “A vertically periodic defected ground structure and its application in reducing the size of microwave circuits,” *IEEE Microwave Compon. Lett.*, Vol. 12, No. 12, 479–481, 2002.
  22. Lim, J.-S., Y.-T. Lee, C.-S. Kim, et al., “A vertically periodic defected ground structure and its application in reducing the size of microwave circuits,” *IEEE Microwave Compon. Lett.*, Vol. 12, No. 12, 479–481, 2002.
  23. Oskouei, H. D., K. Forooghi, and M. Hakkak, “Guided and leaky wave characteristics of periodic defected ground structures,” *Progress In Electromagnetics Research*, PIER 73, 15–27, 2007.
  24. Xue, Q., K. M. Shum, and C. H. Chan, “Novel 1-d microstrip PBG cells,” *IEEE Microwave Guided Wave Lett.*, Vol. 10, No. 10, 403–405, 2000.
  25. Liu, H.-W., Z.-F. Li, X.-W. Sun, et al., “An improved 1d periodic defected ground structure for microstrip line,” *IEEE Microwave Compon. Lett.*, Vol. 14, No. 4, 180–182, 2004.
  26. Mollah, M. N. and N. C. Karmakar, “A novel hybrid defected ground structure as low pass filter,” *IEEE Antennas Propag. Soc. Int. Symp.*, Vol. 4, 3581–3584, 2004.
  27. Insik, C. and L. Bomson, “Design of defected ground structures for harmonic control of active microstrip antenna,” *IEEE Antennas Propag. Soc. Int. Symp.*, Vol. 2, 852–855, 2002.
  28. Park, J.-S., J.-H. Kim, J.-H. Lee, et al., “A novel equivalent circuit and modeling method for defected ground structure and its application to optimization of a DGS lowpass filter,” *IEEE*

- MTT-S Int. Microwave Symp. Digest*, Vol. 1, 417–420, 2002.
29. Karmakar, N. C., “Hi-Z, low-Z defected ground structure,” *Microwave Opt. Tech. Lett.*, Vol. 48, No. 10, 1909–1912, 2006.
  30. Wu, B., B. Li, T. Su, et al., “Equivalent-circuit analysis and lowpass filter design of split-ring resonator DGS,” *Journal of Electromagnetic Waves and Applications*, Vol. 20, 1943–1953, 2006.
  31. Balalem, A., A. R. Ali, J. Machac, et al., “Quasi-elliptic microstrip low-pass filters using an interdigital DGS slot,” *IEEE Microwave Compon. Lett.*, Vol. 17, No. 8, 586–588, 2007.
  32. Xiao, J. K. and Y. Li, “Novel compact microstrip square ring bandpass filters,” *Journal of Electromagnetic Waves and Applications*, Vol. 20, 1817–1826, 2006.
  33. Chen, J., Z.-B. Weng, Y.-C. Jiao, et al., “Lowpass filter design of hilbert curve ring defected ground structure,” *Progress In Electromagnetics Research*, PIER 70, 269–280, 2007.
  34. Xiao, J. K., S. W. Ma, and S. L. Zhang, “Novel compact split ring stepped-impedance resonator (SIR) bandpass filters with transmission zeros,” *Progress In Electromagnetics Research*, PIER 21, 329–339, 2007.
  35. Parui, S. K. and S. Das, “Performance enhancement of microstrip open loop resonator band pass filter by defected ground structures,” *Conf. Proc. IEEE Int. Workshop Antenna Technol. Small Smart Antennas Metamater. Applic.*, 483–486, 2007.
  36. Yang, G. M., R. Jin, et al., “Ultra-wideband bandpass filter with hybrid quasi-lumped elements and defected ground structure,” *IET Microwaves Antennas Propag.*, Vol. 1, No. 3, 733–736, 2007.
  37. Wang, C.-J., S.-Y. Chen, and Y.-C. Lin, “Improvements of microstrip loop filters,” *IEEE Int. Workshop Anti-counterfeiting Secur. Identif.*, 40–43, 2007.
  38. Wu, G.-L., W. M., X.-W. Dai, et al., “Design of novel dual-band bandpass filter with microstrip meander-loop resonator and csrr DGS,” *Progress In Electromagnetics Research*, PIER 78, 17–24, 2008.
  39. Naghshvarian-Jahromi, M. and M. Tayarani, “Miniature planar uwb bandpass filters with circular slots in ground,” *Progress In Electromagnetics Research Letters*, Vol. 3, 87–93, 2008.
  40. Zhenhai, S. and M. Fujise, “Bandpass filter design based on LTCC and DGS,” *Asia Pacific Microwave Conf. Proc. APMC*, Vol. 1, 2–3, 2005.
  41. Zhang, Y. L., W. Hong, K. Wu, et al., “Novel substrate integrated



- waveguide cavity filter with defected ground structure,” *IEEE Trans. Microwave Theory Tech.*, Vol. 53, No. 4, 1280–1287, 2005.
42. Sharma, R., T. Chakravarty, S. Bhooshan, and A. B. Bhattacharyya, “Design of a novel 3 db microstrip backward wave coupler using defected ground structure,” *Progress In Electromagnetics Research*, PIER 65, 261–273, 2006.
  43. Choi, H.-J., J.-S. Lim, Y.-C. Jeong, et al., “Doherty amplifier using load modulation and phase compensation DGS microstrip line,” *36th European Microwave Conf.*, 352–355, 2006.
  44. Hosseini, S. A., Z. Atlasbaf, and K. Forooghi, “Two new loaded compact palnar ultra-wideband antennas using defected ground structures,” *Progress In Electromagnetics Research B*, Vol. 2, 165–176, 2008.
  45. Zainud-Deen, S. H., M. E. S. Badr, E. El-Deen, et al., “Microstrip antenna with defected ground plane structure as a sensor for landmines detection,” *Progress In Electromagnetics Research B*, Vol. 4, 27–39, 2008.
  46. Lim, J.-S., G.-Y. Lee, Y.-C. Jeong, et al., “A 1:6 unequal wilkinson power divider,” *36th Microwave Conf.*, 200–203, 2006.