

## **BANDWIDTH ANALYSIS BY INTRODUCING SLOTS IN MICROSTRIP ANTENNA DESIGN USING ANN**

**V. V. Thakare**

Department of Electronics and Instrumentation  
Anand Engineering College  
Keetham, Agra 282007, India

**P. K. Singhal**

Department of Electronics Engineering  
Madhav Institute of Technology & Science  
Near Gola Ka Mandir, Gwalior 474005, India

**Abstract**—Many applications of microstrip antenna are rendered by their inherent narrow bandwidth. In this paper, a new approach is proposed to design inset feed microstrip antenna with slots in it to improve the antenna bandwidth. This paper deals with the design of slotted microstrip antenna on a substrate of thickness 1.588 mm that gives wideband characteristics using ANN. The illustrated patch antenna gives enhanced bandwidth as compared to antenna with out slots of the same physical dimensions. In the present work an Artificial Neural Network (ANN) model is developed to analyse the bandwidth of the example antenna. The Method of Moments (MOM) based IE3D software has been used to generate training and test data for the ANN. The example antenna is also designed physically with glass epoxy substrate with  $\epsilon_r = 4.7$  for few results for testing the artificial neural network model. The different variants of training algorithm of MLPFFB-ANN (Multilayer Perceptron feed forward back propagation Artificial Neural Network) and RBF-ANN (Radial basis function Artificial Neural Network) has been used to implement the network model. The results obtained from artificial neural network when compared with experimental and simulation results, found satisfactory and also it is concluded that RBF network is more accurate and fast as compared to different variants of backpropagation training algorithms of MLPFFBP.

## 1. INTRODUCTION

Artificial Neural Networks (ANNs) are suitable models for microwave circuit optimization and statistical design. Neuro models are computationally much more efficient than EM models. Once they are trained with reliable learning data obtained from a “fine” model by either EM simulation or measurement, the Neuro models can be used for efficient and accurate optimization and design within the region of training. The Artificial neural networks (ANNs) provide fast and accurate models for microwave modeling, simulation, and optimization. The past decades has seen a phenomenon growth in the development of new tools for microwave CAD. ANNs are computational tools that learn from experience (training), generalize from previous examples to new ones, and abstract essential characteristics from input containing irrelevant data. ANN application to the field of microwaves is very recent. A number of papers [1–10, 12] indicates how ANNs can be used efficiently in analysing and synthesizing various microwave circuits.

The modern trends in wireless communication systems require wide bandwidth antennas, by which the voice, data, and video information can be transmitted. Some of these wireless communication system applications include fixed broadband local multipoint communication services, small mobile units such as cellular phones or other hand held units, laptops and various remote-sensing devices. Most of these applications require miniaturized antennas. The need for increasing the information transfer rate also demands bandwidth enhancement, without sacrificing the performance. These requirements, put together, provide a challenging list of specifications that demand innovation in antenna design beyond known conventional techniques]. As such, the antenna miniaturization for mobile handsets, PC cards, and wireless Personal Digital Assistants has received much attention. For these applications, a slot antenna is of major importance because of its simple structure. When a microstrip slot antenna is fed using a microstrip line it does not add weight and size to the system and is a suitable design for such applications.

Due to many desirable characteristics, microstrip antennas [13–16] are used widely in UHF, microwave, and millimetre-wave applications. However, utilization of these antennas in many applications is hampered by certain inherent disadvantages. Among the most serious of these limitations are low gain and narrow bandwidth. Significant research work has been reported on the enhancement of the bandwidth of microstrip antenna which is otherwise inherently narrowband. Many techniques has been suggested for achieving wide bandwidth [17–23]. Stacked patches, parasitic loading and U shaped microstrip antennas

have been used to enhance the bandwidth. Additional dielectric layers can be used to achieve frequency agility and gain enhancement, and for beam forming. But additional layers increase the weight of the antenna which is again undesirable in wireless environment. The present trend of wireless handheld devices multiple functionality presents challenges for the antenna designer to design multi-frequency antenna in a simple manner and for easy fabrication. Complexities in the design are not in the interest of the rapid growing wireless industries. In this paper, an attempt has been made to design wideband antenna without any complexity.

In microstrip antenna, some parts of radiating surface or ground plane can be removed without any significant changes in antenna performance in terms of radiations patterns as the current distribution remains relatively intact [24]. It is also known that the frequency of a patch antenna can be increased by a capacitive or inductive load. In this paper, a two slot microstrip antenna has been designed implementing the above facts to achieve a wide bandwidth. The proposed ANN model calculates the cut off frequencies  $f_1$  and  $f_2$  and hence the bandwidths  $(f_2 - f_1)$  of the example antenna for different coordinates of the slots i.e.,  $X_1, Y_1$  and  $X_2, Y_2$ . The patch dimensions of the antenna as well as that slot are kept constant for this specific model. The paper presents a simple and novel design for achieving wide bandwidth in microstrip antenna, and it is analysed using MLPFFBP with five different variants of backpropagation training algorithms and RBF ANN.

## 2. DESIGN AND DATA GENERATION

The rectangular microstrip antennas are made up of a rectangular patch with dimensions width ( $W$ ) and length ( $L$ ) over a ground plane with a substrate thickness  $h$  having dielectric constant  $\epsilon_r$ . There are numerous substrates that can be used for the design of microstrip antennas, and their dielectric constants are usually in the range of  $2.2 < \epsilon_r < 12$ . Thin substrates with higher dielectric constants are desirable for microwave circuitry because they require tightly bound fields to minimize undesired radiation and coupling, and lead to smaller element.

The software used to model and simulate the proposed microstrip patch antenna is Zeland Inc's IE3D software. IE3D is a fullwave electromagnetic simulator based on the method of moments. It analyses 3D and multilayer structures of general shapes. It has been widely used in the design of MICs, RFICs, patch antennas, wire antennas, and other RF/wireless antennas. It can be used to calculate

and plot the  $S_{11}$  parameters, VSWR, current distributions as well as the radiation patterns.

As an example an inset feed microstrip antennas is designed to resonate at 10 GHz frequency with dielectric constant ( $\epsilon_r$ ) = 4.7, substrate thickness  $h = 1.588$  mm,  $L = 6$  mm,  $W = 8.88$  mm on a ground plane. All dimensions of the antenna is in mm. The length and the width of the patch are calculated initially by the relationships (1)–(6) given in [25, 26].

$$W = \frac{v_o}{2f_r} \sqrt{\frac{2}{\epsilon_r + 1}} \quad (1)$$

where  $v_o$  is the free space velocity of the light.

$$L = \frac{v_o}{2f_r \sqrt{\epsilon_{reff}}} - 2\Delta L \quad (2)$$

$$\frac{\Delta L}{h} = 0.412 \frac{(\epsilon_{reff} + 0.3) \left(\frac{W}{h} + 0.264\right)}{(\epsilon_{reff} - 0.258) \left(\frac{W}{h} + 0.8\right)} \quad (3)$$

where  $\Delta L$  is extension in length due to fringing effects and effective dielectric constant is given by

$$\epsilon_{reff} = \frac{\epsilon_r + 1}{2} + \frac{\epsilon_r - 1}{2} \left[ 1 + 12 \frac{h}{W} \right]^{-1/2} \quad (4)$$

The transmission line model is applicable to infinite ground planes only. However, for practical considerations, it is essential to have a finite ground plane. It is known that similar results for finite and infinite ground plane can be obtained if the size of the ground plane is greater than the patch dimensions by approximately six times the substrate thickness all around the periphery. Hence, for this design, the ground plane dimensions would be given as:

$$L_g = 6(h) + L = 6(1.588) + 6 = 15.528 \text{ mm} \quad (5)$$

$$W_g = 6(h) + W = 6(1.588) + 8.88 = 18.40 \text{ mm} \quad (6)$$

Figure 1 shows the geometry of inset feed microstrip antenna with two slots in the patch. The patch is energized electromagnetically using 50 ohm microstrip feed line. The length of the current path is increased due to the slot which leads to additional inductance in series. Hence wide bandwidth is generated as the resonant circuits become coupled. The slots aggregate the currents, which give additional inductance controlled by the patch width. IE3D software has been used to calculate the return loss ( $S_{11}$ ) & hence the cut off frequencies  $f_1$  and  $f_2$  of the antenna. Firstly the example antenna is designed without slots in IE3D EM Simulator with patch dimensions  $L = 6$ ,  $W = 8.88$  for resonating frequency of 10 GHz. The bandwidth for the antenna

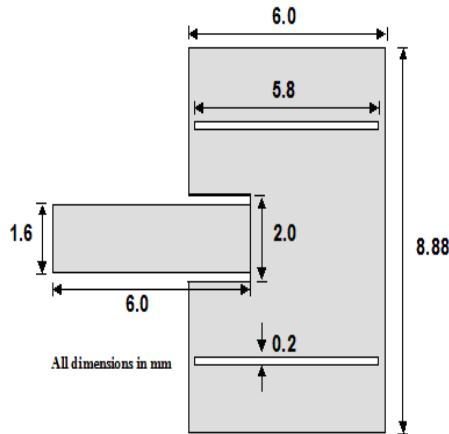

**Figure 1.** Inset feed microstrip antenna with two slots. All dimensions are in mm.

is around 450 MHz. The present work signifies that by introduction of two slots in the same design, the bandwidth gets enhanced about 25%–45%, i.e., from 450 to 650 MHz. The same antenna is designed in IE3D Simulator for different coordinate values of both the slots  $X_1$ ,  $Y_1$  and  $X_2$ ,  $Y_2$  in the specified range ( $X_1 = 0$ ,  $0.5 < Y_1 < 4$  mm,  $X_2 = 0$ ,  $-0.5 < Y_2 < -4$  mm) keeping patch dimensions, slot dimensions,  $\epsilon_r$  and  $h$  constant and the corresponding cut off frequencies are recorded and this data has been used as a training data and test data for MLPFFBP and RBF ANN.

Figure 2 and Figure 3 show the return loss ( $S_{11}$ ) vs. frequency curve for the proposed inset feed microstrip patch antenna without slot and with two slots of same physical patch dimensions. The positions of the slots were varied to see the effect on the microstrip antenna bandwidth. It was observed that antenna performance could be controlled by introducing slots to a large extent in terms of increased bandwidth, improved VSWR, Return loss and radiation properties. As the slots move in  $Y$  direction the bandwidth gets increases for the proposed design. From the present work it can be inferred that as the slots are moving along the  $Y$  axis in both the directions, of course in specified range the bandwidth and other performance parameters are also improving significantly.

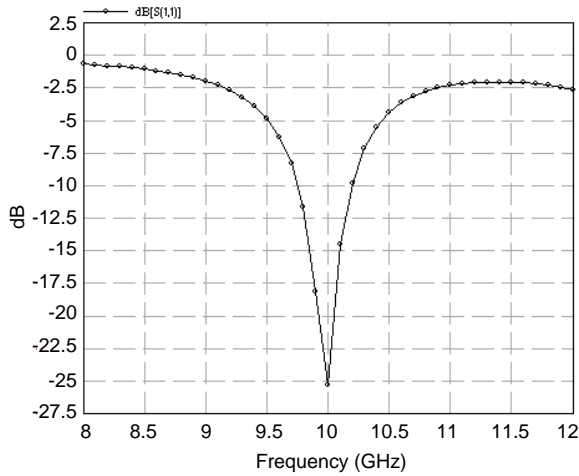

**Figure 2.** The return loss ( $S_{11}$ ) in dB versus resonating frequency of the microstrip patch antenna without slots.

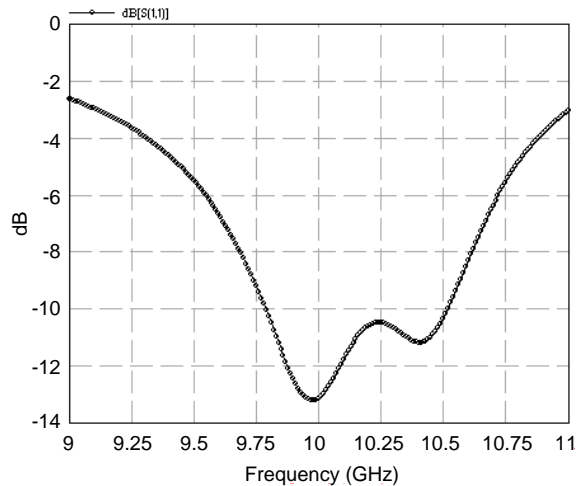

**Figure 3.** The return loss ( $S_{11}$ ) in dB vs. resonating frequency of the slotted microstrip antenna with slots coordinate values  $X_1 = 0, Y_1 = 0.35$  mm and  $X_2 = 0, Y_2 = -3.5$  mm.

### 3. NETWORK ARCHITECTURE AND TRAINING

For the present work three layer network MLPFFBP [27,28] with 5 different training algorithms and RBF network is preferred to model the slotted inset feed microstrip antenna.

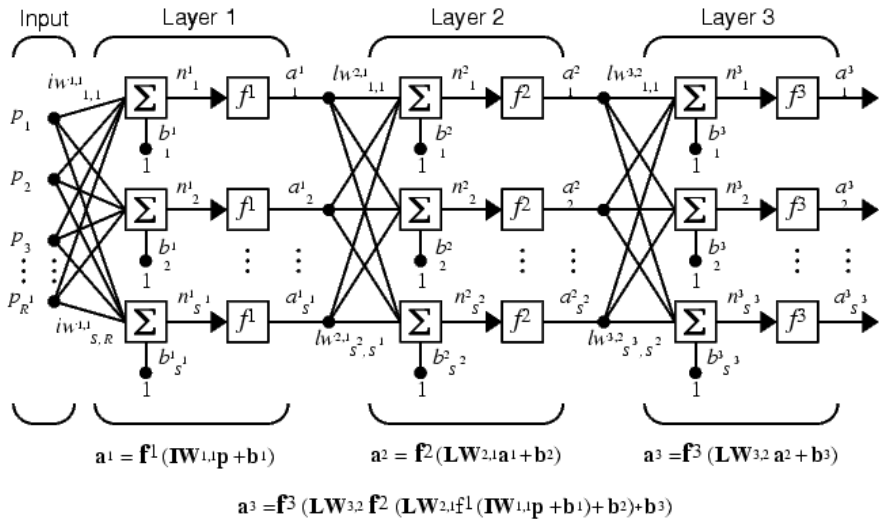

Figure 4. Three layer MLPFFBP network architecture.

### 3.1. Multi Layer Perceptron Feed Forward Back Propagation (MLPFFBP)

MLP networks are feed forward networks trained with the standard back propagation algorithm as shown in Figure 4. They are supervised networks, and also they required a desired response to be trained. With one or two hidden layers they can approximate virtually any input output map. The weights of the network are usually computed by training the network using the back propagation algorithm.

In this paper, three layer multilayer feed-forward back propagation artificial neural network with one hidden layer and trained by different variants of back propagation training algorithms is used to design microstrip antenna. ANN structure (number of layers, number of neurons in each layer, neurons activation function, learning algorithm and training parameters) is not known in advance. Hence the network model is analysed with different number of hidden layers in the structure and also the numbers of processing elements are also varied to acquire the accuracy. Hence it is concluded that three layer MLP with one hidden layer and 25 processing elements in the hidden layer is the optimum network structure for the proposed problem. The network is trained with 5 different training algorithms to achieve the required degree of accuracy and hence compared for network performance.

In the network there are four input neurons in the input layer, 25 hidden neurons in the hidden layer and two output neurons in the output layer. The various inputs to the network are coordinates of both slots, i.e.,  $X_1$ ,  $X_2$ ,  $Y_1$  and  $Y_2$ . The output of the network is bandwidth, i.e.,  $f_1$  and  $f_2$  cut off frequencies. The training time is 45 seconds and training performs in 277 epochs. In this work, different algorithms are used for training the proposed neural model and a comparative evaluation of relative performance is carried out for estimating cut off frequencies  $f_1$  and  $f_2$  of microstrip antenna. In order to evaluate the performance of proposed MLPFFBP-ANN based model for the design of microstrip antenna, simulation results are obtained using IE3D Simulator and generated 220 input-output training patterns and 50 inputs-output test patterns to validate the model. The network has been trained for different coordinate values of both the slots, but in a specified range. During the training process the neural network automatically adjusts its weights and threshold values such that the error  $z$  between predicted and sampled outputs is minimized. The adjustments are computed by the back propagation algorithm. The training algorithm most suitable is trainlm. The error goal is .001 and learning rate is 0.1. The other network parameters used were noise factor of 0.004 and momentum factor of 0.075. The transfer function preferred is tansig and purelin in the architecture.

### 3.2. RBF Networks

Radial basis function network is a feed forward neural network with a single hidden layer that uses radial basis activation functions for hidden neurons. RBF networks are applied for various microwave modeling purposes. The RBF neural network has both a supervised and unsupervised component to its learning. It consists of three layers of neurons — Input, hidden and output. The hidden layer neurons represent a series of centers in the input data space. Each of these centers has an activation function, typically Gaussian. The activation depends on the distance between the presented input vector and the centre. The further the vector is from the centre, the lower is the activation and vice versa. The generation of the centers and their widths is done using an unsupervised  $k$ -means clustering algorithm. The centers and widths created by this algorithm then form the weights and biases of the hidden layer, which remain unchanged once the clustering has been done. A typical RBF network structure is given in Figure 5. The parameters  $c_{ij}$  and  $\varepsilon_{ij}$  are centers and standard deviations of radial basis activation functions. Commonly used radial basis activation functions are Gaussian and Multiquadratic. Given the



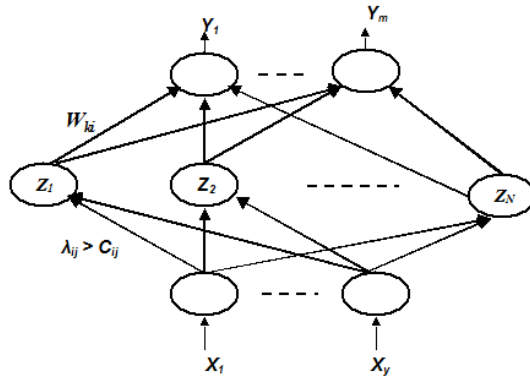

**Figure 5.** RBF network architecture.

inputs  $x$ , the total input to the  $i$ th hidden neuron  $\gamma_i$  is given by (7).

$$\gamma_i = \sqrt{\sum_{j=1}^n \left( \frac{x_j - c_{ij}}{\lambda_{ij}} \right)^2}, \quad i = 1, 2, 3, \dots, N \quad (7)$$

where  $N$  is the number of hidden neurons. The output value of the  $i$ th hidden neuron is  $z_{ij} = \sigma(\gamma_i)$  where  $\sigma(\gamma_i)$  is a radial basis function. Finally, the outputs of the RBF network are computed from hidden neurons as shown in (8)

$$y_k = \sum_{i=0}^N w_{ki} z_{ki} \quad (8)$$

where  $w_{ki}$  is the weight of the link between the  $i$ th neuron of the hidden layer and the  $k$ th neuron of the output layer. Training parameters  $w$  of the RBF network include  $w_{k0}, w_{ki}, c_{ij}, \lambda_{ij}, k = 1, 2, \dots, m, i = 1, 2, \dots, N, j = 1, 2, \dots, n$ .

In the RBF network, the spread value was chosen as 0.01, which gives the best accuracy. The network was trained with 220 samples and tested with 50 samples. In the structure there are 4 inputs and 2 outputs were used for the analysis ANN. RBF networks are more fast and effective as compared to MLPFFBP for this antenna design example. The RBF network automatically adjusts the number of processing elements in the hidden layer till the defined accuracy is reached. In the present RBF ANN model the network is choosing 50 processing elements in the hidden layer. The training time is 35 seconds and training performs in 175 epochs and the training algorithm is unsupervised k-means clustering algorithm.

**Table 1.** Comparison of different variants of back propagation training for the analysis of rectangular patch inset feed microstrip antenna.

Training algorithms	number of epochs	Mean square error	Estimation of $f_1$ cutoff frequency		Estimation of $f_2$ cutoff frequency	
			Maximum Absolute Error Training data	Test data	Maximum Absolute Error Training data	Test data
Levenberg – Marquardt (LM)	277	1.3897e-027	0.0012	0.0847	0.0014	0.1257
Scale Congugate Gradient Backpropagation (SCGBP)	350	9.5204e-005	0.0061	0.314	0.0052	0.4190
Fletcher Powell CG Backpropagation(FPCGBP)	540	0.0004	0.0277	1.042	0.0746	1.7840
Gradient Decent With Momentum(GDM)	606	1.45.8	0.0390	1.98	0.0472	1.5431
Adaptive Gradient Decent(AGD)	564	0.02415	0.0534	1.602	0.0744	1.8247
Radial Basis Function (RBF)	175	7.2334e-029	0.0003	0.0425	0.0005	0.1399

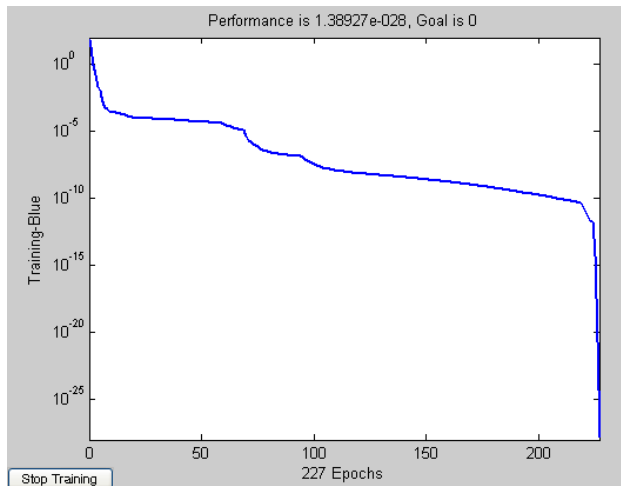

**Figure 6.** Number of epochs to achieve minimum mean square error level in case of MLPFFBP with LM as training algorithm.

## 4. RESULTS AND CONCLUSION

### 4.1. Results

It has been established from Table 1 that the Levenberg-Marquardt algorithm with structure (4-25-2) is the optimal model to achieve optimal values of speed of convergence and accuracy achieved in case of MLPFFBP. It has been observed that total number of 227 epochs as shown in Figure 6 is needed to reduce MSE level to a low value 1.3897e-027 for three layers MLPFFBP with Levenberg-Marquardt (LM)

training algorithm and transig as a transfer function. Achievement of such a low value of performance goal (MSE) indicates that trained ANN model is an accurate model for designing the Microstrip patch antenna. The maximum absolute error at each value  $f_1$  and  $f_2$  (cut off frequencies) antenna is estimated for the random values but in specified range, i.e., the range for which network is trained. It is established that average maximum absolute value of absolute error between actual and estimated values of cut off frequencies of microstrip antenna is found to be only 0.0027 as shown in Figure 7. Various transfer functions are

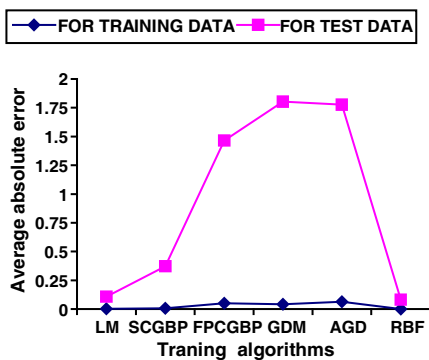

**Figure 7.** Graph showing variation of average absolute error for different variants of back propagation training algorithm.

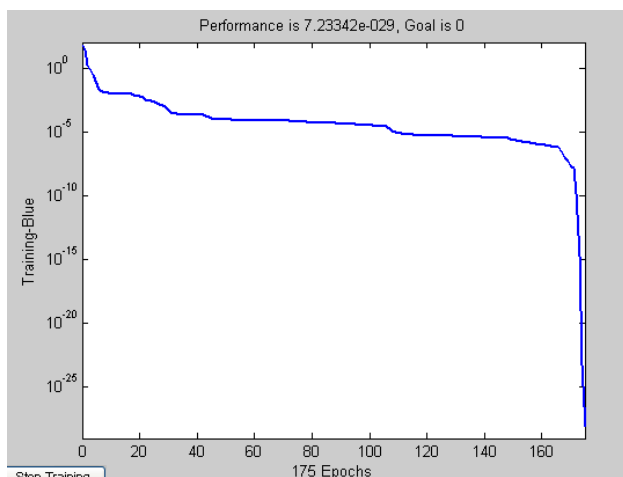

**Figure 8.** Number of epochs to achieve minimum mean square error level in case of RBF network.

used for training the network and average minimum MSE on training and CV data is measured. It is observed that *tansig* is most suitable transfer function for the present work. The MLP neural network is trained using learning rules namely Levenberg-Marquardt (LM), Scale Conjugate Gradient Back propagation (SCGBP), Fletcher Powell CG Back propagation (FPCGBP), Gradient Decent with Momentum (GDM) and Adaptive Gradient Decent (AGD), Minimum MSE and maximum absolute error is measured on training and CV data and is indicated in Table 1. It is concluded that Levenberg-Marquardt is most suitable learning rule for our neural network with 4-25-2 structure. For generalization the randomized data is fed to the network and is trained for different hidden layers. It is observed that MLP with single hidden layer gives better performance as shown in Figure 9. The number of Processing Elements (PEs) in the hidden layer is also varied. The network is trained and minimum MSE is obtained when 25 PEs are used in hidden layer as shown in Figure 10.

As the work signifies RBF ANN is also used to model the inset feed slotted antenna. A Radial Basis Function (RBF) neural network has an input layer, a hidden layer and an output layer. The neurons in the hidden layer contain Gaussian transfer functions whose outputs are inversely proportional to the distance from the centre of the neuron. It is established from Table 1 and Figure 7 that RBF is giving results not only more accurate but fast also the presented RBF network has performed training in only 175 epochs as shown in Figure 8. So it is concluded that RBF architecture is better from MLPFFBP to the accuracy of 99.1%.

To see the validity of the artificial network the network was tested against four patterns generated by physically fabricating the antenna on glass epoxy substrate for different slot position in the patch with dielectric substrate of thickness 1.588 mm and  $\epsilon_r = 4.7$ .

The results generated by EM simulator, ANN and experiment are given in Table 2. Firstly, the results obtained from IE3D are compared with Neuro computational method. The result matches extraordinarily satisfactorily. Then, the example antenna is designed practically with the slots of same dimensions for 10 GHz resonating frequency for the six combinations of the coordinates in the specified range as shown in Table 2, and it is found that results are in good agreement with simulation and ANN. The paper proposes the use of inset feed for rectangular patch antenna with reduced feed complexities. The proposed antenna can be used conveniently in broadband communications.

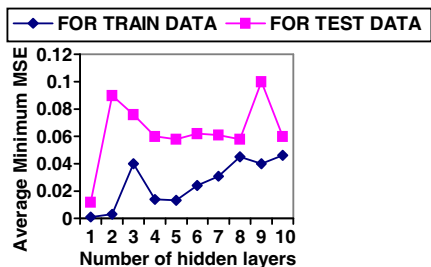

**Figure 9.** Graph showing variation of average minimum MSE on training and test data set for different numbers of hidden layers in the network.

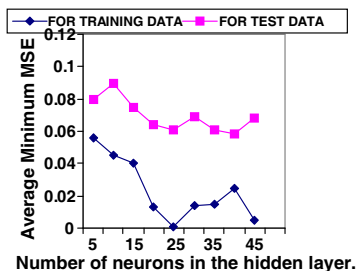

**Figure 10.** Graph showing variation of average minimum MSE on training and test data set for different numbers of neurons in the hidden layer.

**Table 2.** Comparison of results of IE3D, ANN and experiment for bandwidth calculation.

$L$ of slot ,mm	$W$ of slot, mm	$X_1, y_1$ coordinate, 1st slot	$X_2, y_2$ coordinate, 2nd slot	BW IE3D, GHz	BW MLPFFBP GHz	BW RBF, GHz	BW EXPERIMENT, GHz	BW Without Slots, GHz
5.2	0.2	0,0.5	0, -0.5	0.5915	0.5912	0.5914	0.5917	0.45
5.2	0.2	0,1.0	0, -1.0	0.5894	0.5811	0.5896	0.57124	0.45
5.2	0.2	0,1.5	0, -1.5	0.5981	0.5874	0.5982	0.5985	0.45
5.2	0.2	0,0.5	0, -0.5	0.5849	0.5884	0.5835	0.5802	0.45
5.2	0.2	0,2.5	0, -2.5	0.6032	0.6029	0.6030	0.6028	0.45
5.2	0.2	0,3.5	0, -3.5	0.6491	0.6496	0.6490	0.6494	0.45

### 4.2. Conclusion

The inset fed microstrip patch antenna is a versatile structure which can be modified by the addition of simple slots in the design structure to overcome selected limitations inherent to conventional patch antennas. The antenna can provide improved bandwidth enhancement, under certain conditions, while maintaining many of the desirable features of conventional patches. It must be emphasized that improving a particular characteristic of the antenna may result in the degradation of one or more of the other performance characteristics. In many cases the benefits of the enhancement of the desired characteristic

outweigh the disadvantages of any incidental performance degradation. In this paper, we have attempted to indicate to the reader one of the approaches to improve performance and same is modelled using MLPFFBP and RBF-ANN. The results obtained with the present technique were closer to the experimental results generated by a physically fabricating the example antenna on the glass epoxy substrate. Table 1 shows the comparison of results of different variant of back propagation algorithm of MLPFFBP and RFB network ANN. The paper concludes that results obtained using present ANN techniques are quite satisfactory and followed the experimental trend and also that RBF is giving the best approximation to the design as compared to MLPFFBP.

## ACKNOWLEDGMENT

The authors acknowledge the management of AEC, Agra India and MITS Gwalior. India for supporting this research work.

## REFERENCES

1. Zhang, Q. J. and K. C. Gupta, *Neural Networks for RF and Microwave Design*, Artech House Publishers, 2000.
2. Watson, P. M. and K. C. Gupta, "Design and optimization of CPW circuits using EM ANN models for CPW components," *IEEE Transactions on Microwave Theory and Techniques*, Vol. 45, No. 12, 2515–2523, Dec. 1997.
3. Zaabab, A. H., Q. J. Zhang, and M. Nakhla, "Analysis and optimization of microwave circuits & devices using neural network models," *IEEE MTT-S Digest*, 393–396, 1994.
4. Naser-Moghaddasi, M., P. D. Barjoei, and A. Naghsh, "Heuristic artificial neural network for analysing and synthesizing rectangular microstrip antenna," *IJCSNS International Journal of Computer Science and Network Security*, Vol. 7, No. 12, Dec. 2007.
5. Türker, N., F. Günes, and T. Yildirim, "Artificial neural design of microstrip antennas," *Turk. J. Elec. Engin.*, Vol. 14, No. 3, 2006.
6. Peik, S. E., G. Coutts, and R. R. Mansour, "Application of neural networks in microwave circuit modelling," *Electrical and computer Engineering, 1998, IEEE Canadian Conference*, Vol. 2, 928–931, May 24–28, 1998.
7. Devi, S., D. C. Panda, and S. S. Pattnaik, "A novel method of using artificial neural networks to calculate input impedance of

- circular microstrip antenna,” *Antennas and Propagation Society International Symposium*, Vol. 3, 462–465, June 16–21, 2002.
8. Mishra, R. K. and A. Patnaik, “Neural network-based CAD model for the design of square-patch antennas,” *IEEE Trans. on Antennas Propagat.*, Vol. 46, No. 12, 1890–1891, Dec. 1998.
  9. Patnaik, A., R. K. Mishra, G. K. Patra, and S. K. Dash, “An artificial neural network model for effective dielectric constant of microstrip line,” *IEEE Trans. on Antennas Propagat.*, Vol. 45, No. 11, 1697, Nov. 1997.
  10. Karaboga, D., K. Guney, S. Sagiroglu, and M. Erler, “Neural computation of resonant frequency of electrically thin and thick rectangular microstrip antennas,” *IEEE Proceedings — Microwaves, Antennas and Propagation*, Vol. 146, No. 2, 155–159, Apr. 1999.
  11. Guney, K. and N. Sarikaya, “Resonant frequency calculation for circular microstrip antennas with a dielectric cover using adaptive network-based fuzzy inference system optimized by various algorithms,” *Progress In Electromagnetic Research*, PIER 72, 279–306, 2007.
  12. Pattnaik, S. S., D. C. Panda, and S. Devi, “Radiation resistance of coax-fed rectangular microstrip antenna using artificial neural networks,” *Microwave and Optical Technology Lett.*, Vol. 34, No. 1, 51–53, Jul. 5, 2002.
  13. James, J. R., P. S. Hall, and C. Wood, *Microstrip Antenna Theory and Design*, Peter Peregrines (IEE), Stevenage, UK, 1981.
  14. Guney, K., “Resonant frequency of a tuneable rectangular microstrip patch antenna,” *Microwave and Optical Technology Lett.*, Vol. 7, 581–585, 1994.
  15. Herscovici, N., “New consideration in the design of microstrip antenna,” *IEEE Trans. on Antennas Propagat.*, Vol. 46, No. 6, 807–812, Jun. 1998.
  16. Pattnaik, S. S., G. Lazzi, and O. P. Gandhi, “On the use of wideband wide band high gain microstrip antenna for mobile telephones,” *IEEE Transaction on Antenna and Propagation Magazine*, Vol. 40, No. 1, 88–90, Feb. 1998.
  17. Palit, S. K. and N. Vijayasinghe, “Broadband microstrip antenna design,” *China J. Radio Sci.*, 670–673, 1995.
  18. Croq, F., G. Kossiavas, and A. Papienik, “Stacked resonators for bandwidth enhancement: A comparison of two feeding techniques,” *IEEE Proc. Microwave Antennas Propagation*, Vol. 40, No. 4, 303–308, 1993.

19. Sanchez-Hernandez, D. and I. D. Robertson, "A survey of broadband microstrip patch antennas," *Microwave Journal*, 60–84, Sept. 1996.
20. Lee, K. F., K. M. Luk, K. F. Tong, Y. L. Yung, and T. Huyuh, "Experimental study of the rectangular patch with a U-shaped slot," *IEEE International Symposium on Antennas and Propagation Digest*, 10–13, Jul. 21–26, 1996.
21. Palit, S. K. and A. Hamadi, "Design and development of wideband and dual band microstrip antenna," *IEEE Proceedings — Microwave, Antennas, and Propagation*, Vol. 146, No. 1, 1094–1100, Feb. 1999.
22. Robert, B., T. Razvan, and A. Papernik, "Compact patch antenna integrates monolithic amp," *Microwave & RF*, Vol. 34, No. 4, 115–125, Mar. 1995.
23. Palit, S. K. and A. Hamadi, "Design and development of wideband and dual microstrip antennas," *IEEE Proceedings — Microwaves, Antenna and Propagation*, Vol. 146, No. 1, 35–39, Feb. 1999.
24. Yong, F., X. Zhang, X. Ye, and Y. Rahmat-Samii, "Wide-band E-shaped patch antennas for wireless communication," *IEEE Trans. on Antennas Propagat.*, Vol. 49, No. 7, 1094–1100, Jul. 2001.
25. Balanis, C. A., *Antenna Theory*, John Wiley & Sons, Inc., 1997.
26. Pozar, D. M., "Microstrip antenna," *Proc. IEEE*, Vol. 80, 79–81, 1992.
27. Hassoun, M. H., *Fundamentals of Artificial Neural Networks*, Chapter 8, New Delhi, Prentice Hall of India, 1999.
28. Haykin, S., *Neural Networks*, 2nd edition, pHI, 2003.