

TIME DOMAIN ANALYTICAL MODELING OF A STRAIGHT THIN WIRE BURIED IN A LOSSY MEDIUM

S. Šesnić^{1,*}, D. Poljak¹, and S. Tkachenko²

¹Faculty of Electrical Engineering, Mechanical Engineering and Naval Architecture, University of Split, Ruđera Boškovića 32, Split 21000, Croatia

²Department of Electrical Engineering and Information Technology, Otto-von-Guericke University Magdeburg, Magdeburg D-39106, Germany

Abstract—This paper deals with an analytical solution of the time domain Pocklington equation for a straight thin wire of finite length, buried in a lossy half-space and excited via the electromagnetic pulse (EMP) excitation. Presence of the earth-air interface is taken into account via the simplified reflection coefficient arising from the Modified Image Theory (MIT). The analytical solution is carried out using the Laplace transform and the Cauchy residue theorem. The EMP excitation is treated via numerical convolution. The obtained analytical results are compared to those calculated using the numerical solution of the frequency domain Pocklington equation combined with the Inverse Fast Fourier Transform (IFFT).

1. INTRODUCTION

Transient analysis of thin wire scatterers has been a subject of considerable interest of many prominent researchers for more than fifty years. There are numerous applications of these studies in antenna theory and propagation, as well as in electromagnetic compatibility (EMC), such as buried power and telecommunication cables, respectively, grounding, target identification, stimulation of biological tissue, etc. [1–10].

The electromagnetic field coupling to thin wire scatterers can be treated via different approaches. Transient response can be obtained by means of direct time domain modeling, or via an indirect approach

Received 21 July 2011, Accepted 26 September 2011, Scheduled 4 November 2011

* Corresponding author: Silvestar Šesnić (ssesnic@fesb.hr).

in the frequency domain, where the time domain solution is obtained using certain inverse transform procedures [1, 2]. The principal advantage of the indirect approach is the relative simplicity of both the formulation and the selected numerical treatment. On the other hand, direct time modeling ensures better physical insight, accurate modeling of highly resonant structures, possibility of calculating only early time period and easier implementation of nonlinearities [2, 11].

The formulation of the problem in thin wire transient analysis is usually governed by some variants of integral or integro-differential equations (Hallen or Pocklington type), respectively. The solution of such equations is, in most cases, undertaken using some variant of numerical methods. Numerical modeling is widely used for solving various complex problems. On the other hand, analytical solution can be obtained when dealing with canonical problems, using a carefully chosen set of approximations [12–15]. These approximations are usually posed by limiting parameters for which the solution is valid or by using the approximation procedures to simplify the governing equations. The advantage of analytical solutions over numerical ones is the ability to “follow up” the procedure with the complete control of adopted approximations. In this way, the insight into the physical characteristics of the problem is ensured, which is, when using numerical methods, rather complex task. Also, analytical solutions are readily implemented for benchmark purposes, as well as some fast engineering estimation of phenomena. Furthermore, analytical solutions can be used within some hybrid approaches for modeling complex structures, where computational time can be significantly reduced [2].

Valuable contributions in the area of analytical solutions of integral equations in electromagnetics are given by R. W. P. King et al. [12, 13]. In [12, 13] analytical solutions of different expressions, arising from the antenna analysis, in either transmitting or receiving mode, are derived primarily in the frequency domain. S. Tkachenko derives the analytical solution for the current induced along the wire above perfectly conducting (PEC) ground using the transmission line modeling (TLM) for LF excitations [14]. This model is extended to the case of high frequencies in [15].

Time domain analytical modeling is not investigated to a great extent and papers on the subject are rather scarce. Such papers usually deal with a narrow set of parameters for which the model is valid (free space, homogeneous medium) [16–19]. Hoorfar and Chang give the solution for transient response of thin wire in free space using singularity expansion method [16]. Velazquez and Mukhedar derive analytical solution for the current induced along a grounding electrode,

based on the TL model [17]. Chen gives the solution for transient response of infinite antenna in a lossy medium, driven by a voltage generator [18]. Analytical solution for transient response based on the full wave model is needed, as TL approximation fails to account for radiation effects. For the simple case of a straight thin wire embedded in a homogeneous lossy medium analytical solution has been reported by the authors in [20].

In the second part of this paper, Pocklington integro-differential formulation for current induced on a thin wire buried in a lossy half-space, illuminated by a transmitted electromagnetic wave is posed in the time domain. The influence of the boundary is taken into account via simplified reflection coefficient arising from Modified Image Theory. Thin wire approximation is used throughout the paper [2, 12]. In the third part, the corresponding Pocklington equation is solved using the approximation of the unknown current function, Laplace transform and Cauchy residue theorem. Results obtained with these relations are compared, in the fourth section, with the results obtained via numerical solution of corresponding Pocklington equation in the frequency domain and subsequent Inverse Fast Fourier Transform (IFFT) [2]. The results obtained via different approaches agree satisfactorily.

2. TIME DOMAIN FORMULATION

A perfectly conducting thin wire of length L and radius a , is horizontally buried in a lossy medium at depth d . The electrical properties of a medium are permittivity ε and conductivity σ . The wire is illuminated by a transmitted part of a transient electromagnetic (EM) wave. For the sake of simplicity, only normal incidence is considered. The geometry of the problem is shown in Figure 1.

The governing Pocklington integro-differential equation for half-space is derived gradually. First, thin wire in a homogeneous lossy medium is considered.

A time dependant electric field can be expressed in terms of electric scalar φ and magnetic vector potential \vec{A} , respectively [1, 21]

$$\vec{E} = -\frac{\partial \vec{A}}{\partial t} - \nabla \varphi. \quad (1)$$

Performing certain mathematical manipulations, the following relation is obtained [11]

$$\frac{1}{\mu} \nabla^2 \vec{A} - \sigma \frac{\partial \vec{A}}{\partial t} - \varepsilon \frac{\partial^2 \vec{A}}{\partial t^2} = \frac{1}{\mu} \nabla \left(\nabla \cdot \vec{A} + \mu \sigma \varphi + \mu \varepsilon \frac{\partial \varphi}{\partial t} \right) - \vec{J}_i, \quad (2)$$

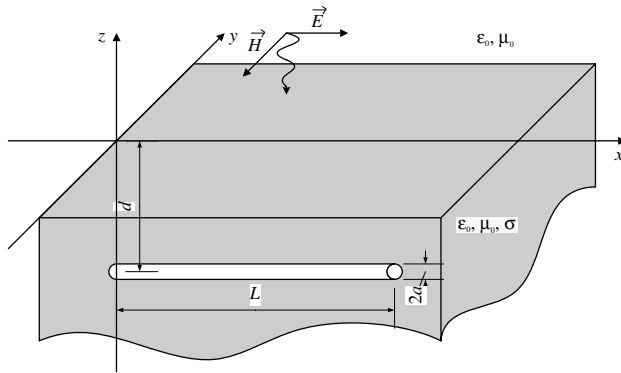

Figure 1. Horizontal straight thin wire buried in a lossy medium.

where \vec{J}_i represents current density produced by the external source.

Adopting the Lorentz gauge [21]

$$\nabla \cdot \vec{A} + \mu\sigma\varphi + \mu\varepsilon \frac{\partial\varphi}{\partial t} = 0, \tag{3}$$

(2) becomes

$$\nabla^2 \vec{A} - \mu\sigma \frac{\partial \vec{A}}{\partial t} - \mu\varepsilon \frac{\partial^2 \vec{A}}{\partial t^2} = -\mu \vec{J}_i, \tag{4}$$

representing the wave equation for magnetic vector potential.

Combining the Equations (1)–(4), the electric field can be expressed as follows

$$\left(\mu\varepsilon \frac{\partial}{\partial t} + \mu\sigma \right) \vec{E} = \nabla^2 \vec{A} - \mu\sigma \frac{\partial \vec{A}}{\partial t} - \mu\varepsilon \frac{\partial^2 \vec{A}}{\partial t^2}. \tag{5}$$

The solution of (4) is the particular integral [2]

$$\vec{A}(\vec{r}, t) = \mu \int_0^t \int_{V'} \vec{J}_i(\vec{r}', t') g(\vec{r}, \vec{r}', t, t') dV' dt', \tag{6}$$

assuming the current density \vec{J}_i to be the only source in the considered domain. $g(\vec{r}, \vec{r}', t, t')$ represents the Green’s function of a homogeneous lossy medium that can be obtained by solving the following differential equation

$$\left(\nabla^2 - \mu\sigma \frac{\partial}{\partial t} - \mu\varepsilon \frac{\partial^2}{\partial t^2} \right) g(\vec{r}, \vec{r}', t, t') = \delta(\vec{r}, \vec{r}', t, t'). \tag{7}$$

The solution of (7) can be written in the form [22]

$$g(\vec{r}, \vec{r}', t, t') = e^{-\frac{1}{\tau_g} \frac{R}{v} \delta(t - t' - \frac{R}{v})} + \frac{\sigma^2}{16\pi\epsilon^2 v} e^{-\frac{t-t'}{\tau_g}} \frac{I_1(u)}{u}, \quad (8)$$

where time constant is defined as

$$\tau_g = \frac{2\epsilon}{\sigma} \quad (9)$$

and the distance from the source to observation point is given with

$$R = |\vec{r} - \vec{r}'|, \quad (10)$$

while $I_1(u)$ represents the modified Bessel function of the first kind and first order with the argument u defined as

$$u = \frac{1}{\tau_g} \sqrt{(t - t')^2 - \left(\frac{R}{v}\right)^2}. \quad (11)$$

The second term in (8) can be neglected if the condition $\sigma^2 \ll 16\pi\epsilon^2 v$ is satisfied [11], so the Green's function can be defined as

$$g(\vec{r}, \vec{r}', t, t') = e^{-\frac{1}{\tau_g} \frac{R}{v} \delta(t - t' - \frac{R}{v})}. \quad (12)$$

Combining Equations (6) and (12) and taking into account the thin wire approximation [12], the axial component of vector potential is obtained [2]

$$A_x(x, t) = \frac{\mu}{4\pi} \int_0^L I\left(x', t - \frac{R}{v}\right) \frac{e^{-\frac{1}{\tau_g} \frac{R}{v}}}{R} dx', \quad (13)$$

where the distance from the source point in the axis of the wire to the observation point on the wire surface is defined as

$$R = \sqrt{(x - x')^2 + a^2}. \quad (14)$$

For the case of dissipative half-space, shown in Figure 1, the expression for magnetic vector potential (13) has to be expanded to account for the ground-air interface, as shown in Figure 2.

In the frequency domain, the additional term due to the image wire in the air is obtained by multiplying the reflection coefficient with the corresponding Green's function. To obtain the expression for a lossy half-space, first the relation (13) is transformed into frequency domain applying the Laplace transform. The following equation is obtained

$$A_x(x, s) = \frac{\mu}{4\pi} \int_0^L I(x', s) e^{-\frac{R}{v} s} \frac{e^{-\frac{1}{\tau_g} \frac{R}{v}}}{R} dx', \quad (15)$$

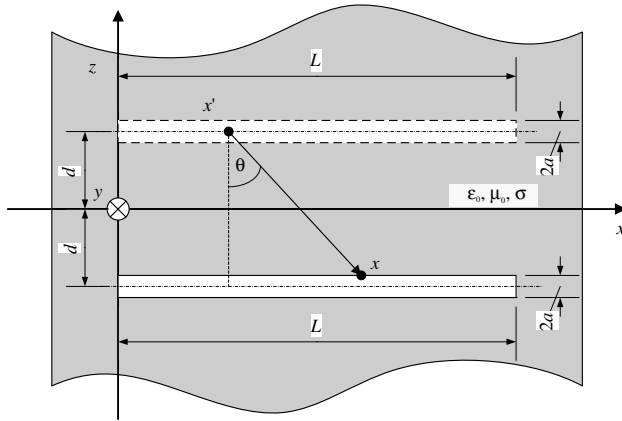

Figure 2. Wire and its image due to image theory.

where $s = j\omega$ is the Laplace variable.

Now, the expression for the magnetic vector potential can be written as follows

$$\begin{aligned}
 A_x(x, s) = &= \frac{\mu}{4\pi} \int_0^L I(x', s) e^{-\frac{R}{v}s} \frac{e^{-\frac{1}{\tau_g} \frac{R}{v}}}{R} dx' \\
 &- \frac{\mu}{4\pi} \int_0^L \Gamma_{ref}^{MIT}(s) I(x', s) e^{-\frac{R^*}{v}s} \frac{e^{-\frac{1}{\tau_g} \frac{R^*}{v}}}{R^*} dx' \quad (16)
 \end{aligned}$$

where $\Gamma_{ref}^{MIT}(s)$ is the reflection coefficient due to earth-air interface.

The reflection coefficient arises from the Modified Image Theory and is given by [23]

$$\Gamma_{ref}^{MIT}(s) = -\frac{s\tau_1 + 1}{s\tau_2 + 1}, \quad (17)$$

where

$$\begin{aligned}
 \tau_1 &= \frac{\varepsilon_0(\varepsilon_r - 1)}{\sigma}, \\
 \tau_2 &= \frac{\varepsilon_0(\varepsilon_r + 1)}{\sigma}.
 \end{aligned} \quad (18)$$

Applying the inverse Laplace transform to Equation (17), a time domain counterpart for the reflection coefficient (17) is obtained in the form

$$\Gamma_{ref}^{MIT}(t) = -\left[\frac{\tau_1}{\tau_2} \delta(t) + \frac{1}{\tau_2} \left(1 - \frac{\tau_1}{\tau_2} \right) e^{-\frac{t}{\tau_2}} \right]. \quad (19)$$

The distance from the source point on the image wire in the air to the observation point on the original wire in the ground is given as

$$R^* = \sqrt{(x - x')^2 + 4d^2}. \tag{20}$$

Applying the inverse Laplace transform to Equation (16), the following time domain expression is obtained

$$A_x(x, t) = \frac{\mu}{4\pi} \int_0^L I \left(x', t - \frac{R}{v} \right) \frac{e^{-\frac{1}{\tau_g} \frac{R}{v}}}{R} dx' - \frac{\mu}{4\pi} \int_0^t \int_0^L \Gamma_{ref}^{MIT}(\tau) I \left(x', t - \frac{R^*}{v} - \tau \right) \frac{e^{-\frac{1}{\tau_g} \frac{R^*}{v}}}{R^*} dx' d\tau, \tag{21}$$

where the convolution integral is applied instead of multiplication in the Laplace domain. Combining the relations for the electric field (5) and for magnetic vector potential (21), the derived time domain integro-differential Pocklington equation is obtained

$$\left(\mu\varepsilon \frac{\partial}{\partial t} + \mu\sigma \right) E_x^{tr}(t) = - \left(\frac{\partial^2}{\partial x^2} - \mu\sigma \frac{\partial}{\partial t} - \mu\varepsilon \frac{\partial^2}{\partial t^2} \right) \cdot \left[\frac{\mu}{4\pi} \int_0^L I \left(x', t - \frac{R}{v} \right) \frac{e^{-\frac{1}{\tau_g} \frac{R}{v}}}{R} dx' - \frac{\mu}{4\pi} \int_0^t \int_0^L \Gamma_{ref}^{MIT}(\tau) I \left(x', t - \frac{R^*}{v} - \tau \right) \frac{e^{-\frac{1}{\tau_g} \frac{R^*}{v}}}{R^*} dx' d\tau \right]. \tag{22}$$

Solving the integro-differential Equation (22), the space-time dependant current is obtained. Knowing the current distribution, other parameters of interest can be determined.

Apart from this special case of Pocklington equation, it is worth mentioning some general information about the equation itself. The Pocklington equation is used for obtaining the current induced along the wire. The current can be induced either by incident electromagnetic wave or by impressed voltage source. It can be used both in frequency and time domain and it is, generally speaking, easier to solve (numerically) in frequency domain [2]. Pocklington equation can be written for different electromagnetic problems, such as: thin wire, thick wire, curved wire, free space, lossy half-space, multilayered medium, wire array, arbitrary wire configurations, to name just a few. As opposed to differential formulations that are, generally, used to solve domain problems, integral formulations are intended for solving

problems with (un)known sources, as is in this case, induced current. Pocklington equation is obtained directly from Maxwell's equations, using magnetic vector potential as auxiliary variable. Because of this, Pocklington equation approach is considered to be a full wave approach, since only used assumption is well known Lorentz gauge (3) that is needed to define the divergence of magnetic vector potential [2]. In this way, no generality is lost and results obtained by solving Pocklington equations are considered to be most accurate.

3. ANALYTICAL SOLUTION OF POCKLINGTON EQUATION

Under some conditions it is possible to handle differential operator and integral operator from Equation (22) separately. First, the solution of the integral operator is acquired, using certain approximations.

The first integral from the right-hand side of Equation (22) can be, generally, written as

$$\int_0^L I \left[x', t - \frac{\sqrt{(x-x')^2 + a^2}}{v} \right] \frac{e^{-\frac{1}{\tau_g} \frac{\sqrt{(x-x')^2 + a^2}}{v}}}{\sqrt{(x-x')^2 + a^2}} dx' = f(x, t) \quad (23)$$

The accurate analytical integration of kernel in expression (23) is not possible to obtain [24, 25]. On the other hand, the solution is possible to acquire with the aid of numerical methods and those solutions are well known in literature [1, 2, 26]. Using certain approximations, the analytical solution of (23) can be obtained. In 1938, Hallen used an approximation to solve corresponding integral equation in the frequency domain [27]. Adjustment of that approximation has recently been used to obtain the solution of integral equation in time domain [19, 28].

To handle the integral operator in Equation (23), addition and subtraction technique is applied

$$\begin{aligned} & \int_0^L I \left(x', t - \frac{R}{v} \right) \frac{e^{-\frac{1}{\tau_g} \frac{R}{v}}}{R} dx' \\ &= \int_0^L \left[I \left(x, t - \frac{a}{v} \right) + I \left(x', t - \frac{R}{v} \right) - I \left(x, t - \frac{a}{v} \right) \right] \frac{e^{-\frac{1}{\tau_g} \frac{R}{v}}}{R} dx'. \quad (24) \end{aligned}$$

Now, the right hand side of the Equation (24) can be written as

$$\begin{aligned} & \int_0^L \left[I\left(x, t - \frac{a}{v}\right) + I\left(x', t - \frac{R}{v}\right) - I\left(x, t - \frac{a}{v}\right) \right] \frac{e^{-\frac{1}{\tau_g} \frac{R}{v}}}{R} dx' \\ &= \int_0^L I\left(x, t - \frac{a}{v}\right) \frac{e^{-\frac{1}{\tau_g} \frac{R}{v}}}{R} dx' \\ & \quad + \int_0^L \left[I\left(x', t - \frac{R}{v}\right) - I\left(x, t - \frac{a}{v}\right) \right] \frac{e^{-\frac{1}{\tau_g} \frac{R}{v}}}{R} dx'. \end{aligned} \tag{25}$$

Adopting the following assumption [17, 28]

$$I\left(x', t - \frac{R}{v}\right) - I\left(x, t - \frac{a}{v}\right) \equiv 0 \tag{26}$$

Equation (24) becomes

$$\int_0^L I\left(x', t - \frac{R}{v}\right) \frac{e^{-\frac{1}{\tau_g} \frac{R}{v}}}{R} dx' = I\left(x, t - \frac{a}{v}\right) \int_0^L \frac{e^{-\frac{1}{\tau_g} \frac{R}{v}}}{R} dx'. \tag{27}$$

The approximation (26) has proven to be valid in papers by Tijhuis et al. [19, 28]. The apparent advantage of this approximation is replacing the integral equation with corresponding ordinary differential equation with the unknown induced current. The drawback of this approximation is that time retardation is assumed to be a/v instead of R/v , which results in the loss of the information on radiated energy due to current reflection on the wire free ends. This information is significant when dealing with free space. In this paper, however, the primary concern is to deal with a lossy medium where the approximation is valid. Substituting (27) into (22) yields

$$\begin{aligned} & \left(\mu\varepsilon \frac{\partial}{\partial t} + \mu\sigma \right) E_x^{tr}(t) \\ &= - \left(\frac{\partial^2}{\partial x^2} - \mu\sigma \frac{\partial}{\partial t} - \mu\varepsilon \frac{\partial^2}{\partial t^2} \right) \cdot \left[\frac{\mu}{4\pi} I\left(x, t - \frac{a}{v}\right) \int_0^L \frac{e^{-\frac{1}{\tau_g} \frac{R}{v}}}{R} dx' \right. \\ & \quad \left. - \frac{\mu}{4\pi} \int_0^t \Gamma_{ref}^{MIT}(\tau) I\left(x, t - \frac{a}{v} - \tau\right) \int_0^L \frac{e^{-\frac{1}{\tau_g} \frac{R^*}{v}}}{R^*} dx' d\tau \right]. \end{aligned} \tag{28}$$

The next step in solving the differential Equation (28) is to apply the Laplace transform. Taking into account following assumptions

$$\begin{aligned} E_x(t) &= 0, \quad t \leq 0 \\ I\left(x, t - \frac{a}{v}\right) &= 0, \quad t \leq 0, \\ \frac{\partial I\left(x, t - \frac{a}{v}\right)}{\partial t} &= 0, \quad t < 0 \end{aligned} \quad (29)$$

and performing the Laplace transform, the following equation is obtained

$$\begin{aligned} &(\mu\varepsilon s + \mu\sigma)E_x^{tr}(s) \\ &= -\frac{\mu}{4\pi} \left(\frac{\partial^2}{\partial x^2} - \mu\sigma s - \mu\varepsilon s^2 \right) \\ &\cdot I(x, s)e^{-\frac{a}{v}s} \left[\int_0^L \frac{e^{-\frac{1}{\tau_g} \frac{R}{v}}}{R} dx' - \Gamma_{ref}^{MIT}(s) \int_0^L \frac{e^{-\frac{1}{\tau_g} \frac{R^*}{v}}}{R^*} dx' \right]. \end{aligned} \quad (30)$$

Satisfying the condition

$$\sigma \ll \frac{2}{a} \sqrt{\frac{\varepsilon}{\mu_0}}, \quad (31)$$

which is achieved for the medium conductivity of order 10 mS/m, integrals in (30) can be solved analytically as follows [14, 28]

$$\int_0^L \frac{e^{-\frac{1}{\tau_g} \frac{R}{v}}}{R} dx' \approx \int_0^L \frac{1}{R} dx' \approx 2 \ln \frac{L}{a}; \quad (32)$$

$$\int_0^L \frac{e^{-\frac{1}{\tau_g} \frac{R^*}{v}}}{R^*} dx' \approx \int_0^L \frac{1}{R^*} dx' \approx 2 \ln \frac{L}{2d}. \quad (33)$$

Imposing Equation (17), it can be written

$$\begin{aligned} \Psi(s) &= \int_0^L \frac{e^{-\frac{1}{\tau_g} \frac{R}{v}}}{R} dx' - \Gamma_{ref}^{MIT}(s) \int_0^L \frac{e^{-\frac{1}{\tau_g} \frac{R^*}{v}}}{R^*} dx' \\ &= 2 \left(\ln \frac{L}{a} + \frac{s\tau_1 + 1}{s\tau_2 + 1} \ln \frac{L}{2d} \right). \end{aligned} \quad (34)$$

Now, relation (30) can be written as

$$(\mu\varepsilon s + \mu\sigma)E_x^{tr}(s) = -\frac{\mu}{4\pi} \left(\frac{\partial^2}{\partial x^2} - \mu\sigma s - \mu\varepsilon s^2 \right) I(x, s)e^{-\frac{a}{v}s} \Psi(s). \quad (35)$$

Adopting the expression for the propagation constant of a lossy medium

$$\gamma = \sqrt{\mu\varepsilon \left(s^2 + \frac{\sigma}{\varepsilon} s \right)}, \tag{36}$$

the following differential equation is obtained

$$\frac{\partial^2 I(x, s)}{\partial x^2} - \gamma^2 I(x, s) = -\frac{4\pi}{\mu s \Psi(s)} e^{\frac{a}{v}s} \gamma^2 E_x^{tr}(s). \tag{37}$$

The solution of (37) can be readily obtained, prescribing the boundary conditions at the wire ends

$$\begin{aligned} I(0, s) &= 0 \\ I(L, s) &= 0 \end{aligned} \tag{38}$$

The solution of (37) can be written as

$$I(x, s) = \frac{4\pi e^{\frac{a}{v}s}}{\mu s \Psi(s)} E_x^{tr}(s) \left[1 - \frac{\cosh\left(\gamma\left(\frac{L}{2} - x\right)\right)}{\cosh\left(\gamma\frac{L}{2}\right)} \right]. \tag{39}$$

To obtain the solution for the current distribution in time domain, inverse Laplace transform has to be performed featuring the Cauchy residue theorem [29]

$$f(t) = \lim_{y \rightarrow \infty} \frac{1}{j2\pi} \int_{x-jy}^{x+jy} e^{ts} F(s) ds = \sum_{k=1}^n \text{Res}(s_k), \tag{40}$$

where residues of the function are defined as

$$\text{Res}(s_k) = \lim_{s \rightarrow s_k} (s - s_k) e^{ts} F(s), \tag{41}$$

while s_k denotes the poles of the function $F(s)$.

The excitation function in the Laplace domain is of the form

$$E_x^{tr}(s) = 1 \text{ [V/m]} \tag{42}$$

which corresponds to impulse excitation in time domain.

Calculating all the residues of the function (39) and undertaking the inverse transform as in (40), the following expression is obtained

$$\begin{aligned} &I(x, t) \\ &= \frac{4\pi}{\mu} \left\{ R(s\Psi) \left[1 - \frac{\cosh\left(\gamma\Psi\left(\frac{L}{2} - x\right)\right)}{\cosh\left(\gamma\Psi\frac{L}{2}\right)} \right] e^{(t+\frac{a}{v})s\Psi} \right. \\ &\quad \left. - \frac{\pi}{\mu\varepsilon L^2} \sum_{n=1}^{\infty} \frac{2n-1}{\pm\sqrt{b^2 - 4c_n s_{1,2n}} \Psi(s_{1,2n})} \sin \frac{(2n-1)\pi x}{L} e^{(t+\frac{a}{v})s_{1,2n}} \right\}, \tag{43} \end{aligned}$$

where coefficients $R(s_\Psi)$ and s_Ψ represent physical properties of the system, taking into account properties of the medium, as well as the dimensions of the wire and the distance from the interface

$$R(s_\Psi) = \frac{1}{2 \ln \frac{L}{2d} \frac{s_\Psi}{s_\Psi \tau_2 + 1} \left(\tau_1 - \tau_2 \frac{s_\Psi \tau_1 + 1}{s_\Psi \tau_2 + 1} \right)},$$

$$s_\Psi = -\frac{\ln \frac{L}{a} + \ln \frac{L}{2d}}{\tau_1 \ln \frac{L}{a} + \tau_2 \ln \frac{L}{2d}}.$$
(44)

Furthermore, other coefficients in relation (43) are given as follows

$$\gamma_\Psi = \sqrt{\mu\varepsilon (s_\Psi^2 + bs_\Psi)}$$

$$s_{1,2n} = \frac{1}{2} \left(-b \pm \sqrt{b^2 - 4c_n} \right)$$

$$b = \frac{\sigma}{\varepsilon}$$

$$c_n = \frac{(2n-1)^2 \pi^2}{\mu\varepsilon L^2}, \quad n = 1, 2, 3, \dots$$
(45)

Expression (43) represents the space-time distribution of the current along the straight wire buried in a lossy medium excited by an impulse excitation, i.e., it represents an impulse response. The part with infinite series can be truncated after first ten terms achieving very good convergence.

Furthermore, the response to an arbitrary excitation can be obtained performing the corresponding convolution. The excitation function is plane wave in the form of double exponential electromagnetic pulse tangential to the wire [30]

$$E_x(t) = E_0 \left(e^{-\alpha t} - e^{-\beta t} \right).$$
(46)

The transmitted electric field in the Laplace (frequency) domain can be written as follows [2]

$$E_x^{tr}(s) = \Gamma_{tr}(s) E_x(s) e^{-\gamma d}$$
(47)

where $\Gamma_{tr}(s)$ represents the Fresnel transmission coefficient defined as [21]

$$\Gamma_{tr}(s) = \frac{2\sqrt{s\varepsilon_0}}{\sqrt{s\varepsilon + \sigma} + \sqrt{s\varepsilon_0}}.$$
(48)

The expression for the transmitted field (47) is too complex for the use of analytical convolution, therefore the numerical convolution is applied to obtain the results for the induced current. Numerical convolution is carried out with the discrete samples obtained from inverse Fourier transform of expression (47) and the discrete samples of Equation (43).

4. RESULTS

In this section some illustrative results obtained via the proposed method are presented. The analytical results are obtained using the presented method of convolution and are compared to the results obtained by numerical solution of the corresponding frequency domain Pocklington equation using the Galerkin-Bubnov Indirect Boundary Element Method (GB-IBEM) and the Inverse Fast Fourier Transform (IFFT) [2].

Evidently, Pocklington equation is used in both models, in that way making both a full wave model. The main difference lies in the method of solving integro-differential equation. The approximations used for analytical solution have been stated and explained. However, frequency domain model used for comparison is solved numerically in the frequency domain. Generally, numerical solution is considered to be more accurate, because fewer approximations are made in calculation procedure, so these results are considered to be a benchmark.

After extensive numerical tests, it has been found that optimal parameters for numerical convolution outlined at the end of the third part, are: number of samples $n_t = 2^{16}$ and period of observation $T = 33 \mu\text{s}$. With these parameters, accurate results are obtained in reasonable time period.

All results for the current response are calculated using the standard EMP excitation [30]

$$E_0 = 1 \text{ V/m}, \quad \alpha = 4 \cdot 10^6 \text{ 1/s}, \quad \beta = 4.78 \cdot 10^8 \text{ 1/s}. \quad (49)$$

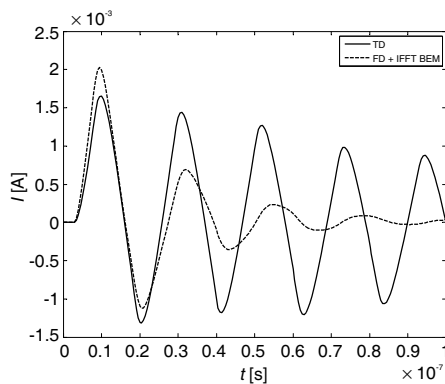

Figure 3. Transient current at the center of the straight wire, $L = 1 \text{ m}$, $d = 30 \text{ cm}$, $\sigma = 1 \text{ mS/m}$.

The first geometry of interest to be analyzed is a wire of length $L = 1$ m, radius $a = 5$ mm and the burial depth $d = 30$ cm. Relative electric permittivity of a medium is given as $\varepsilon_r = 10$ and a conductivity is varied with the respective values $\sigma = 1$ mS/m, 10 mS/m and 100 mS/m. The results calculated via different methods are shown in Figures 3 to 7.

The largest discrepancies of the results can be seen in Figure 3. But even there, a relatively good agreement between the results for the

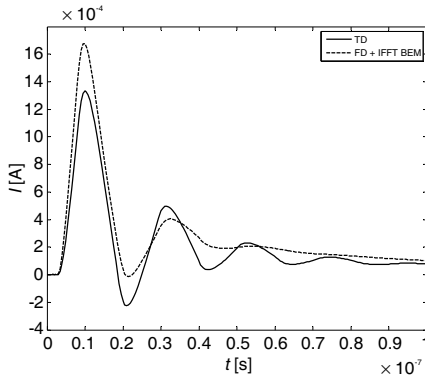

Figure 4. Transient current at the center of the straight wire, $L = 1$ m, $d = 30$ cm, $\sigma = 10$ mS/m.

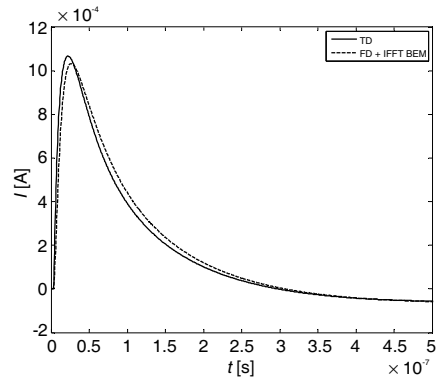

Figure 5. Transient current at the center of the straight wire, $L = 1$ m, $d = 30$ cm, $\sigma = 100$ mS/m.

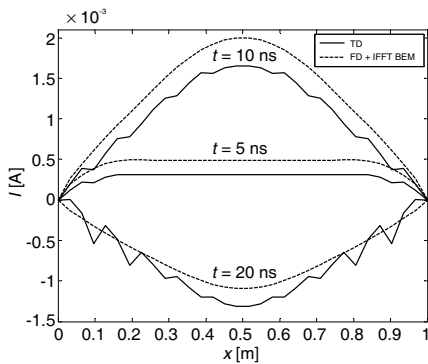

Figure 6. Current along the wire at different time instants, $L = 1$ m, $d = 30$ cm, $\sigma = 1$ mS/m.

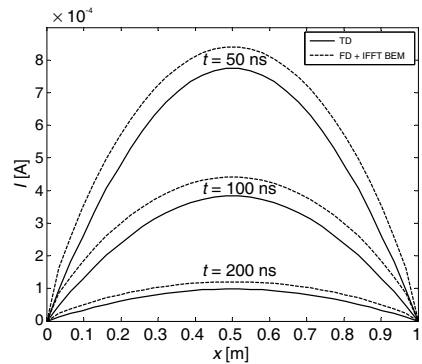

Figure 7. Current along the wire at different time instants, $L = 1$ m, $d = 30$ cm, $\sigma = 100$ mS/m.

early time behavior ($t < 20$ ns) is obvious. The discrepancies at a later time instants can be readily explained taking into account the nature of the approximations used throughout the formulation. Namely, it is reasonable not to expect approximation (26) to provide valid results for very short wire ($L < 1$ m) immersed in a low conducting medium ($\sigma < 1$ mS/m). However, even for a short wire, for higher conductivities of a medium (Figures 4 and 5) relatively good agreement between the results is achieved. This can be explained with larger dissipation of energy through more conductive medium.

In Figures 6 and 7, current distribution along the wire at different time instants is shown. The parameters correspond to geometries shown in Figures 3 and 5, respectively. Smaller discrepancies can be observed, but overall agreement is very good.

Figures 8 to 10 show the transient current induced at the center of straight longer wires buried in a lossy medium with $\sigma = 1$ mS/m. The length of the wire is $L = 10$ m and 20 m, respectively, while burial depth varies as $d = 4$ m, 1 m, 15 m, respectively.

As it can be seen in Figure 8, for a 10 m-long wire the agreement between the results is rather satisfactory. In Figures 9 and 10, another interesting phenomenon can be observed. Namely, for 20 m-long wire, a relatively low discrepancy between the results can be seen, due to the implementation of simplified approximation for the reflection coefficient arising from Modified Image Theory (19). The discrepancy that can be observed for smaller burial depths is caused by the vicinity of the earth-air interface. As the burial depth increases, as in Figure 10, it can be seen that the results agree satisfactorily because

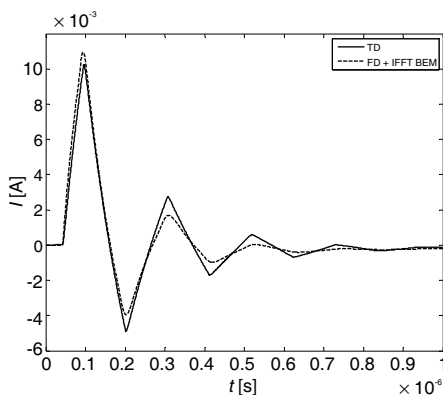

Figure 8. Transient current at the center of the straight wire, $L = 10$ m, $d = 4$ m, $\sigma = 1$ mS/m.

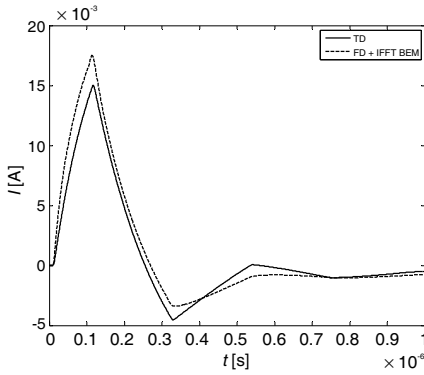

Figure 9. Transient current at the center of the straight wire, $L = 20$ m, $d = 1$ m, $\sigma = 1$ mS/m.

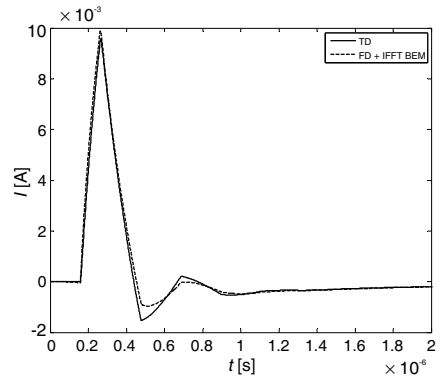

Figure 10. Transient current at the center of the straight wire, $L = 20$ m, $d = 15$ m, $\sigma = 1$ mS/m.

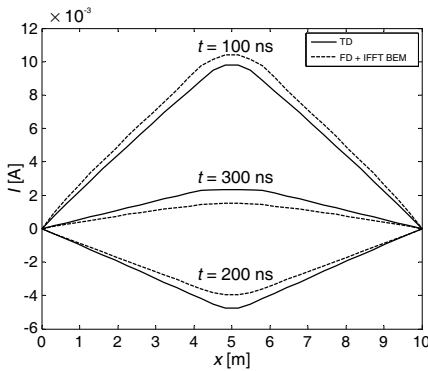

Figure 11. Current along the wire at different time instants, $L = 10$ m, $d = 4$ m, $\sigma = 1$ mS/m.

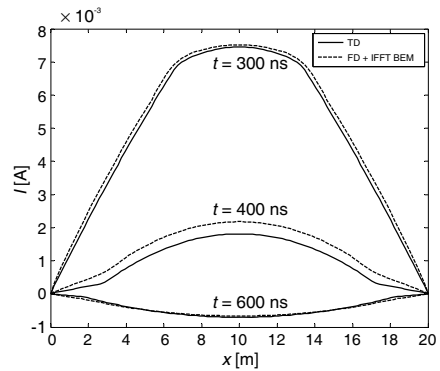

Figure 12. Current along the wire at different time instants, $L = 20$ m, $d = 15$ m, $\sigma = 1$ mS/m.

of the diminishing influence of the two media interface.

In Figures 11 and 12, also, a current distribution along the wire is shown. The results are obtained for different time instants. The parameters of the geometries correspond to those shown in Figures 8 and 10, respectively. The overall agreement between the methods is very good.

From examples given in Figures 3 to 12, it can be concluded that two variables affect the agreement of the results the most; wire length and medium conductivity. Generally speaking, the longer the wire, the

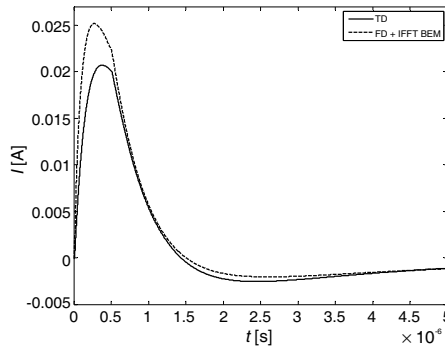

Figure 13. Transient current at the center of the straight wire, $L = 100$ m, $d = 1$ m, $\sigma = 0.833$ mS/m.

better is the agreement and the higher the conductivity, the better is the agreement. The lower limit for wire length is about 1 m, and for medium conductivity is about 1 mS/m. However, these limits are not to be taken strictly, because the influence of these two parameters is coupled. If the wire is longer, the results are in better agreement even for a lower conductivity of the medium, and vice versa.

The last example is related to Figure 13 representing the transient current at the center of a 100 m-long wire, buried at depth $d = 1$ m, with the electrical properties of the media $\epsilon_r = 9$ and $\sigma = 0.833$ mS/m. These values correspond to realistic configuration of power cable layout.

It can be seen in the Figure 13, that there is a small discrepancy in the early time behavior of the induced current which manifests in a smaller maximum value. Namely, the conductivity of the medium is very low and the cable is buried relatively close to the boundary, so, taking into account the adopted approximations, the obtained results agree rather satisfactorily.

5. CONCLUSION

In this paper, the direct analytical solution of the time domain Pocklington integro-differential equation for straight buried thin wire is presented. The governing equation is posed in time domain and subsequently solved using the approximation of the unknown current function, Laplace transform and Cauchy residue theorem, thus obtaining analytical expression for space-time varying induced current. The numerical convolution of the impulse response with the incident transmitted wave is performed to obtain the transient response for

actual excitation. The results are compared with the results obtained via numerical solution of corresponding Pocklington equation in the frequency domain and subsequent IFFT. The results obtained via different approaches agree satisfactorily.

REFERENCES

1. Rao, S. M., *Time Domain Electromagnetics*, S. M. Rao (ed.), Academic Press, San Diego, USA, 1999.
2. Poljak, D., *Advanced Modeling in Computational Electromagnetic Compatibility*, Wiley-Interscience, New Jersey, USA, 2007.
3. Miller, E. K., A. J. Poggio, and G. J. Burke, "An integro-differential equation technique for the time-domain analysis of thin wire structures. I. The numerical method," *Journal of Computational Physics*, Vol. 12, No. 1, 24–48, May 1973.
4. Bridges, G. E., "Transient plane wave coupling to bare and insulated cables buried in a lossy half-space," *IEEE Transactions on Electromagnetic Compatibility*, Vol. 37, No. 1, 62–70, Feb. 1995.
5. Lorentzou, M. I., N. D. Hatziargyriou, and B. C. Papadias, "Time domain analysis of grounding electrodes impulse response," *IEEE Transactions on Power Delivery*, Vol. 18, No. 2, 517–524, Apr. 2003.
6. Poljak, D. and V. Doric, "Wire antenna model for transient analysis of simple grounding systems, part II: The horizontal grounding electrode," *Progress In Electromagnetics Research*, Vol. 64, 167–189, 2006.
7. Chen, H. T., J.-X. Luo, and D.-K. Zhang, "An analytic formula of the current distribution for the VLF horizontal wire antenna above lossy half-space," *Progress In Electromagnetics Research Letters*, Vol. 1, 149–158, 2008.
8. Zhang, G.-H., M. Xia, and X.-M. Jiang, "Transient analysis of wire structures using time domain integral equation method with exact matrix elements," *Progress In Electromagnetics Research*, Vol. 92, 281–298, 2009.
9. Jin, X. and M. Ali, "Embedded antennas in dry and saturated concrete for application in wireless sensors," *Progress In Electromagnetics Research*, Vol. 102, 197–211, 2010.
10. Seo, D.-W., J.-H. Yoo, K. Kwon, and N.-H. Myung, "A hybrid method for computing the RCS of wire scatterers with an arbitrary orientation," *Progress In Electromagnetics Research B*, Vol. 23, 55–68, 2010.

11. Poljak, D. and N. Kovac, "Time domain modeling of a thin wire in a two-media configuration featuring a simplified reflection/transmission coefficient approach," *Engineering Analysis with Boundary Elements*, Vol. 33, 283–293, 2009.
12. King, R. W. P., G. J. Fikioris, and R. B. Mack, *Cylindrical Antennas and Arrays*, Cambridge University Press, Cambridge, UK, 2002.
13. King, R. W. P., "Embedded bare and insulated antennas," *IEEE Transactions on Biomedical Engineering*, Vol. 24, No. 3, 253–260, May 1977.
14. Tkatchenko, S., F. Rachidi, and M. Ianoz, "Electromagnetic field coupling to a line of finite length: Theory and fast iterative solutions in frequency and time domains," *IEEE Transactions on Electromagnetic Compatibility*, Vol. 37, No. 4, 509–517, Nov. 1995.
15. Tkatchenko, S., F. Rachidi, and M. Ianoz, "High-frequency electromagnetic field coupling to long terminated lines," *IEEE Transactions on Electromagnetic Compatibility*, Vol. 43, No. 2, 117–129, May 2001.
16. Hoorfar, A. and D. C. Chang, "Analytic determination of the transient response of a thin-wire antenna based upon an SEM representation," *IEEE Transactions on Antennas and Propagation*, Vol. 30, No. 6, 1145–1152, Nov. 1982.
17. Velazquez, R. and D. Mukhedkar, "Analytical modelling of grounding electrodes transient behavior," *IEEE Transactions on Power Apparatus and Systems*, Vol. 103, No. 6, 1314–1322, Jun. 1984.
18. Chen, K. C., "Transient response of an infinite cylindrical antenna in a dissipative medium," *IEEE Transactions on Antennas and Propagation*, Vol. 35, No. 5, 562–573, May 1987.
19. Tijhuis, A. G., Z. Peng, and A. Rubio Bretones, "Transient excitation of a straight thin-wire segment: A new look at an old problem," *IEEE Transactions on Antennas and Propagation*, Vol. 40, No. 10, 1132–1146, Oct. 1992.
20. Sesnic, S. and D. Poljak, "Time domain analytical modeling of finite length thin wire embedded in homogeneous lossy medium," *SoftCOM 2010 18th International Conference on Software, Telecommunications & Computer Networks*, Split-Bol, 2010.
21. Stratton, J. A., *Electromagnetic Theory*, Wiley-Interscience, New Jersey, USA, 2007.
22. Rothwell, E. J. and M. J. Cloud, *Electromagnetics*, CRC Press,

- Boca Raton, London, New York, Washington, D.C., 2001.
23. Takashima, T., T. Nakae, and R. Ishibashi, "Calculation of complex fields in conducting media," *IEEE Transactions on Electrical Insulation*, Vol. 15, No. 1, 1–7, Feb. 1980.
 24. Polyandin, A. D. and A. V. Manzhurov, *Handbook of Integral Equations*, CRC Press, Boca Raton, London, New York, Washington, D.C., 1998.
 25. Dyakin, V. V. and S. V. Marvin, "Initial-boundary value problem and integrodifferential equations of electrodynamics for an inhomogeneous conductive body," *Computational Mathematics and Mathematical Physics*, Vol. 48, No. 2, 275–283, 2008.
 26. Bost, F., L. Nicolas, and G. Rojat, "A time-domain integral formulation for the scattering by thin wires," *IEEE Transaction on Magnetism*, Vol. 36, No. 4, 868–871, Jul. 2000.
 27. Hallen, E., "Theoretical investigations into the transmitting and receiving qualities of antennæ," *Nova Acta Regiae Societatis Scientiarum Upsaliensis*, Vol. 11, No. 4, 3–44, Nov. 1938.
 28. Bogerd, J. C., A. G. Tijhuis, and J. J. A. Klaasen, "Electromagnetic excitation of a thin wire: A traveling-wave approach," *IEEE Transactions on Antennas and Propagation*, Vol. 46, No. 8, 1202–1211, Aug. 1998.
 29. Schiff, J. L., *The Laplace Transform — Theory and Applications*, Springer-Verlag, New York, USA, 1999.
 30. Tesche, F. M., M. Ianoz, and T. Karlsson, *EMC Analysis Methods and Computational Models*, John Wiley & Sons, Inc., New York, USA, 1997.