

DESIGN OF MILLIMETER-WAVE WIDEBAND MIXER WITH A NOVEL IF BLOCK

M. Z. Zhan^{*}, W. Zhao, and R. M. Xu

EHF Key Laboratory of Fundamental Science, University of Electronics Science and Technology of China, China

Abstract—In this paper, a novel suspended stripline IF block is proposed for the design of millimeter-wave finline balanced mixer which covers the full U-band. In high IF frequency applications, IF block of a finline mixer is needed to act as open terminal for IF signal, and is required to have minimum attenuation for LO signal. For the purpose of reducing the insertion loss of the IF block in the LO path, a novel compact low loss IF block is developed for the first time. Then the IF block, two Schottky diodes, a LPF, a finline to waveguide transition and a suspended stripline to waveguide transition are integrated together to compose the mixer. The RF port matching is designed by using impedance substitution method to achieve better RF return loss. The measured results show that a conversion loss of 4.1 to 9.6 dB over a 20 GHz instantaneous IF bandwidth has been achieved when sweeping RF from 40 to 60 GHz under fixed LO condition. The input $P_{-1\text{dB}}$ power at RF port is higher than 6 dBm, and the return loss of RF port is between -18 to -4 dB.

1. INTRODUCTION

Rapidly expanding activities in millimeter-wave system developments have created an urgent need for broadband mixers for up- or down-converters used in instrument, radiometer, and electronic countermeasure systems. In low cost applications or waveguide interface applications, broadband finline millimeter-wave mixer is preferred, as the finline millimeter-wave mixer probably has the lowest cost-to-performance ratio [1].

But, there are two problems in the traditional method of designing finline mixer. First, IF block used in finline mixer is always realized by

Received 16 April 2012, Accepted 23 May 2012, Scheduled 1 June 2012

* Corresponding author: Ming Zhou Zhan (mzzhan@foxmail.com).

an end-coupled or edge-coupled $\lambda/2$ suspended bandpass filters which are narrow-band filters (5% to 10%) with relatively high insertion loss [1, 2]. Placing the coupling sections on both sides of the suspended substrate or using a multilayer substrate may improve the bandwidth or reduce the insertion loss. However, the alignment of the circuit patterns on the substrates must be very precise, and size of the filters cannot be reduced [3–8]. Secondly, the general method for designing the millimeter-wave circuits is to simulate the linear passive parts of the circuits separately by using three-dimensional field simulation software, such as HFSS, CST, and then export the simulated results as S -parameter files into nonlinear simulator to further optimize and get the return loss, conversion loss, $P_{-1\text{dB}}$, etc. However, finline balance mixer, which uses orthogonal field to form a broadband 180° balun [9–13], cannot be well designed by using the above method. The relationship of the orthogonal fields cannot be exported as S -parameter files to ADS, thus a reliable analysis and optimization of the complete structure with such CAD tools becomes difficult.

In this paper, a novel suspended stripline IF block based on a multi-conductor coupled structure is proposed to reduce the insertion loss of the LO path, and the impedances of the schottky diodes under certain LO power are substituted by impedance boundaries in HFSS when simulating the matching of the RF port. These ideas are very useful for designing a waveguide mixer.

2. CONFIGURATION OF THE U-BAND MIXER

The configuration of the mixer is shown in Fig. 1. RF signal is fed from the right through a finline cosine taper to the reverse paralleled diodes (MA/COM's MA4E2037) out of phase, and LO signal is applied to diodes in phase through a waveguide to suspended stripline transition,

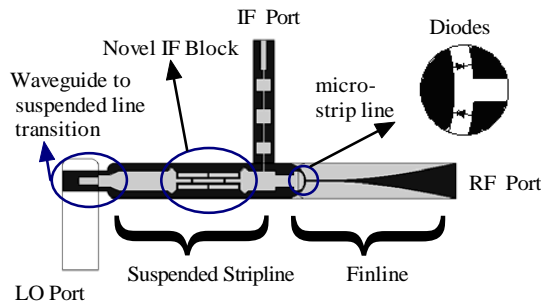

Figure 1. Configuration of the mixer with novel IF block.

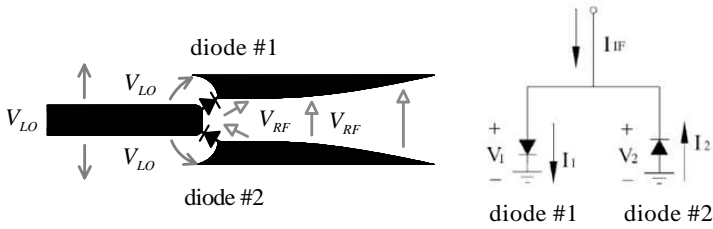

Figure 2. Detail of the diodes, shown the RF and LO phase.

then a suspended stripline IF block. In Fig. 2, the current on the diode #1 can be expressed by the power series [1]:

$$I_1 = aV_1 + bV_1^2 + cV_1^3 + dV_1^4 + \dots \quad (1)$$

$$V_1 = V_{LO} \cos(\omega_{LO}t) + V_{RF} \cos(\omega_{RF}t) \quad (2)$$

where V_1 is the total AC voltage across the diode #1, I_1 is the current, and the lower-case letters represent constants. The current on the diode #2 can be expressed by the power series:

$$I_2 = -aV_2 + bV_2^2 - cV_2^3 + dV_2^4 - \dots \quad (3)$$

$$V_2 = V_{LO} \cos(\omega_{LO}t) - V_{RF} \cos(\omega_{RF}t) \quad (4)$$

where V_2 is the total AC voltage across the diode #2 and I_2 the current. The lower-case letters represent constants. The IF current is as follow:

$$I_{IF} = I_1 - I_2 \quad (5)$$

The k th order spurious responses, those arising from mixing between $m f_{RF} + n f_{LO}$ where $m + n = k$, arise only from the term of k th power in (1) and (3). All (m, n) spurious responses, where m and n are even, are eliminated, and the $(2, 1)$ spurious response is eliminated.

Now, we consider some details of the proposed mixer. As the electric field of the finline and suspended stripline are orthogonal, wideband LO/RF isolation is achieved inherently. In low IF frequency applications, position of the reflection point for IF can be random. However, in high IF applications, it should be close enough to the junction of the IF LPF and suspended stripline. If not, the section between the IF block and the junction of the IF LPF and suspended stripline may introduce a reactance which will cause deterioration of the conversion loss, and the worse case is short for IF signal. On the other hand, insertion loss of the IF block should be designed as low as possible to save the LO power. The diodes are in series at RF frequency and in parallel for the LO and IF. Hence, each diode sees half

the finline characteristic impedance at RF, and twice the IF, LO load impedance, so the relationship between the characteristic impedance of the transmission line should be 1 : 2 : 4. However, diode has reactance, this relationship can only be initial parameters, and diodes must be matched well for better conversion loss. The following two sections are for designing a low loss, wideband and compact IF block and matching the diodes using commercial CAD tools.

3. DESIGN OF THE NOVEL IF BLOCK

A good IF block must have low insertion loss for LO signal and high rejection for IF signal [4]. In wideband application, bandwidth for LO signal is also important [8]. Model of the IF block is shown in Fig. 3. We had proposed a W-band DC/IF block in microstrip transmission line system, and it shows the lowest insertion loss and widest bandwidth among the reported IF block as in [9]. Here, we will realize this multi-conductor coupling structure in suspended transmission line system for the first time. Compared with the IF block structure mentioned in [2–8] and [13–15], this novel block covers full waveguide band range with lower loss and smaller size (only 5.35 mm

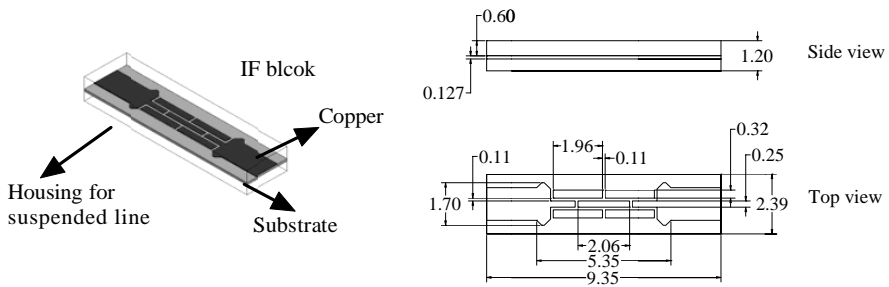

Figure 3. Model of the IF block in HFSS and its parameters in mm.

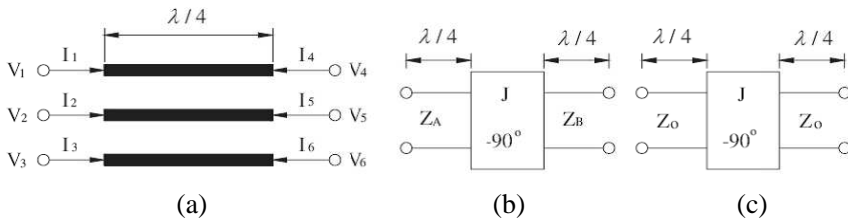

Figure 4. Analysis of the multi-line section.

$\times 1.7 \text{ mm} \times 1.2 \text{ mm}$ as shown in Fig. 3).

The equivalent circuit of the multi-line coupled section is shown in Fig. 4. Analysis method of microstrip line multi-line coupled structure mentioned in [16, 17] is very useful, and we have designed a Ka-band filter and W-band IF block in microstrip line system based on the theory [18, 19]. Although the transmission line system is different here, the initial values of the IF block in Fig. 3 can be obtained using the approach mentioned in [17–19]. The multi-conductor IF block is based on coupling and resonating structure, the length of the coupling section is about a quarter wavelength of the center pass band frequency, the spacing between the lines can be optimized. The circuit patterns are fabricated on the 5 mil height RT5880 substrate, then substrate is mounted by clamping the substrate between one halves of the split reduced height waveguide to form a suspended stripline. For single

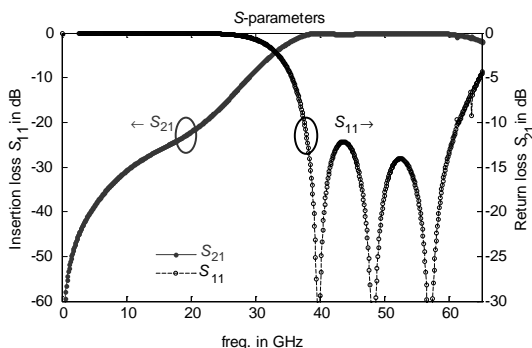

Figure 5. Simulation results of the novel suspended stripline IF block.

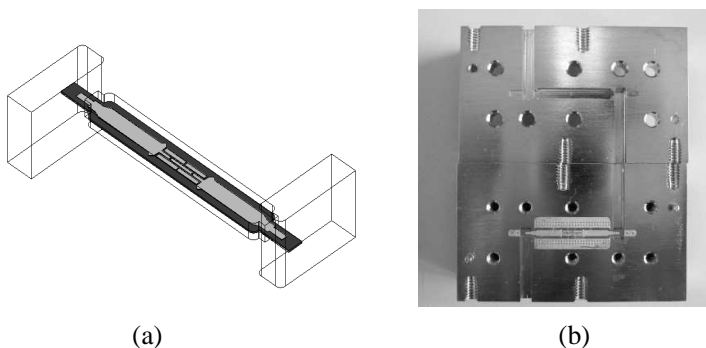

Figure 6. (a) Simulation model in HFSS. (b) Photograph of the novel block with transitions.

mode application, $2.39 \text{ mm} \times 1.2 \text{ mm}$ is chosen for the size of housing. The model in Fig. 3 is optimized in HFSS, and the simulated results are shown in Fig. 5. The rejection is more than 23 dBc from DC \sim 20 GHz for IF, and the maxim insertion loss is 0.2 dB for LO in 40 \sim 60 GHz range. Two U-band waveguide to suspended stripline transitions are added for S -parameter measurement in waveguide interface scalar network analyzer. The model for simulation and its photograph are shown in Fig. 6. In the frequency range of LO, 40 \sim 60 GHz range, the measured insertion loss of LO signal is lower than 0.5 dB. Measurements show good agreement with simulated data as in Fig. 7. This IF block can also be used in other applications, like multipliers, switches or wideband filters.

4. IMPEDANCE MATCHING OF THE DIODES

Finline is a balanced transmission line, so there is no RF voltage between the suspended stripline and ground at this point, thus no RF signal is impressed on the suspended stripline. The connecting point between the diodes is its virtual ground for RF signal. For the same reason, no LO voltage is excited on the RF finline, and the connecting point between the diode and finline is also virtual ground for LO signal. The substitution method for impedance matching of the diodes is based on the conclusions. There are two main steps of the substitution method. Firstly, the impedance under certain LO power must to be calculated. Diode impedance can easily be obtained by filling the spice parameters into the diode model and using large-signal S -parameter simulator in ADS. The LO power is 13 dBm with frequency fixed at 40 GHz. Ignoring losses caused by the waveguide

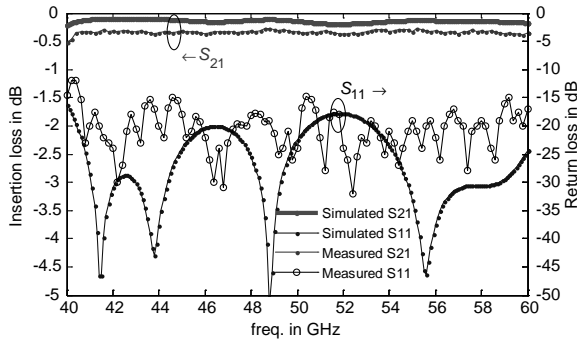

Figure 7. Simulated and measured S -parameters of the IF block in 40 \sim 60 GHz range.

Table 1. Diode impedance Vs LO power 40 GHz.

Power_LO	Z_{in1}
5.000	21.225-j71.787
6.000	23.870-j68.018
7.000	25.815-j64.383
8.000	27.281-j61.031
9.000	28.714-j58.079
10.000	30.668-j55.552
11.000	32.946-j53.256
12.000	35.066-j51.007
13.000	36.378-j48.631

Table 2. Diode impedance Vs LO power 56 GHz.

Power_LO	Z_{in1}
5.000	12.764-j55.204
6.000	15.212-j53.369
7.000	16.834-j51.104
8.000	17.922-j48.835
9.000	18.672-j46.716
10.000	19.282-j44.820
11.000	20.132-j43.221
12.000	21.396-j41.891
13.000	22.839-j40.708

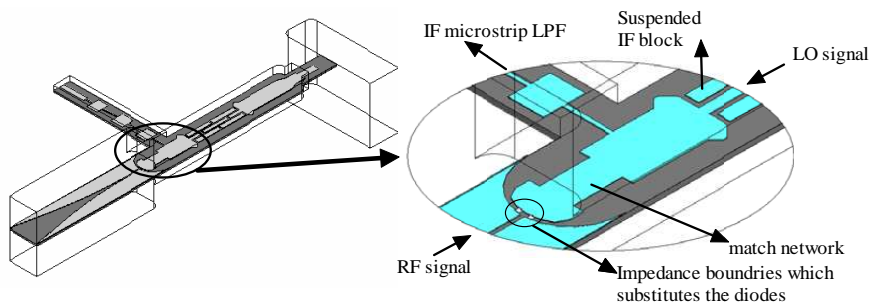

Figure 8. HFSS model for RF matching.

to suspended stripline transition and the suspended stripline IF block, LO power is divided equally on each diode, that means it is 10 dBm on each diode. Impedance versus LO power at 40 GHz for each diode are listed in Table 1. In Table 2, the LO power on each diode is 13 dBm at 56 GHz. These tables show that diode impedance is a function of LO power and frequency.

Secondly, once the LO signal is fixed, the pumped diode impedance at LO frequency becomes a constant, thus the diodes can be substituted by impedance boundary in CAD tools, as in Fig. 8. Impedance matching networks for the RF, LO, and IF port can be optimized in a full-wave 3D simulator, such as HFSS, CST. The ratio of the impedance of RF load, diodes, and IF load is 4 : 2 : 1. But, the diode has a reactance which would deteriorate the matching of RF, LO, and IF port. In paper [9], we have reported two narrow band matching techniques to improve the RF return loss. Here, in Fig. 8, not as in the previous work, the matching network is shifted from the finline section

to the suspended section where the diodes are connected. IF port matching is optimized by sweeping the connecting point of the IF LPF and suspended stripline, and the LO and RF port return loss can be optimized at the same time. Without the resonate slot and discontinues on the finline section in [9], wideband matching of both LO and RF port can be achieved. The equivalent circuit of the diode is a resistor parallel with a capacitor, so the diode impedance should be varies at different RF frequency. From Tables 1 and 2, the imaginary part of Z_{in1} varies a little, so the impedance boundary can be always set at LO frequency for simplification. Based on those reasons, it will be more precise for RF matching when RF frequency is closer to LO frequency. When optimizing, weight of the RF port return loss is always set higher than LO port for better RF return loss. RF impedance matching is optimized by varying the gap of the tapered finline and tuning the size and position of the matching network. The finline slot is a very crucial parameter and 0.07 mm in this design. The simulated return loss is shown in Fig. 13.

5. REALIZATION AND MEASUREMENT OF THE U-BAND MIXER

The diodes which bonded between the end of the suspended stripline and the symmetrical finline tapers are beamlead Schottky diodes. The circuit patterns are fabricated on a 5 mil Rogers5880 substrate and mounted by clamping the substrate between one halves of the split waveguide. The photograph of it is in Fig. 9. Block diagrams for return loss and conversion loss measurements are shown in Fig. 10 and Fig. 11. The measured conversion loss is in Fig. 12. The mixer operates over a 20 GHz IF instantaneous bandwidth with a conversion loss of 4.1 to 9.6 dB when the RF sweeping from 40 to 60 GHz. The measured

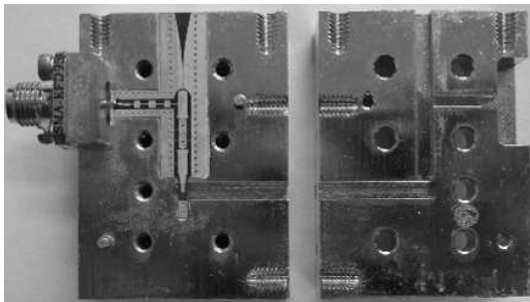

Figure 9. Photograph of the U-band finline mixer.

return loss of RF port is as in Fig. 13. As described in Section 4, the measured return loss is much more satisfied in 40 ~ 50 GHz than 50 ~ 60 GHz range with the simulated data, and the measured results verified this prediction. Furthermore, the $P_{-1\text{dB}}$ power and LO/RF isolation are also measured, they are 6 dBm and 23dBc, respectively. At last, performances of the reported mixers are compared in Table 3. This mixer has the lowest conversion loss, highest $P_{-1\text{dB}}$, and best return loss in the whole 40 ~ 60 GHz range.

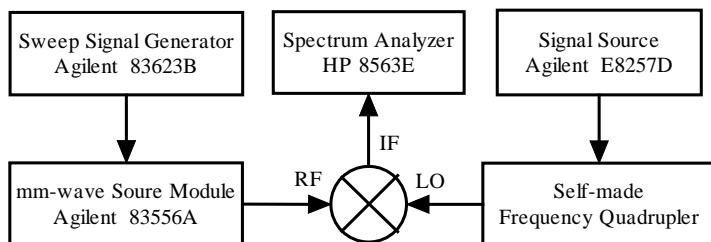

Figure 10. Block diagram for conversion loss measurement.

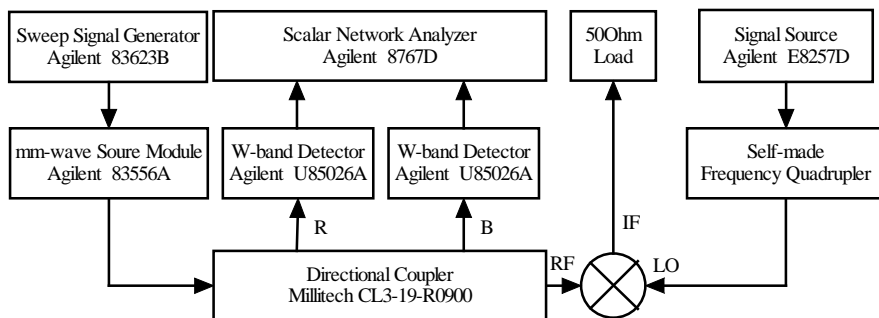

Figure 11. Block diagram for RF return loss measurement.

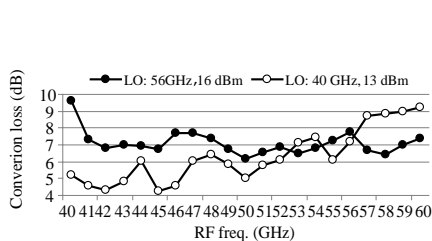

Figure 12. Measured conversion loss.

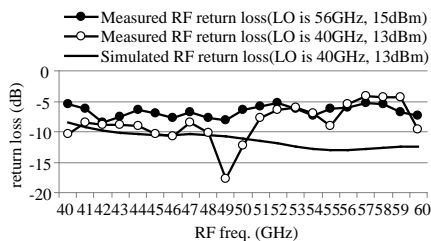

Figure 13. Measured return loss of RF port.

Table 3. Performances of the reported U-band mixers.

Ref. Num.	RF freq. in GHz	Scheme	Conv. loss in dB	RF Return loss in dB	P_{-1dB} in dBm
[9]	44 ~ 53	Schottky Diode mixer	5.4 ~ 7	-18 ~ -10.5	NAN
[10]	40 ~ 60 (IF: 200 MHz)	Subharmonic Diode mixer	7.5 ~ 15	NAN	NAN
[11]	58 ~ 61	Schottky Diode mixer	7 ~ 12	NAN	NAN
[12]	55 ~ 58	3rd harmonic Diode mixer	14.8 ~ 18.5	-30 ~ -7	NAN
[13]	58.5 ~ 60.5	4th harmonic MMIC mixer	11.3 ~ 13.3	NAN	NAN
[14]	40 ~ 60	Subharmonic Diode mixer	7.5 ~ 15	NAN	NAN
[15]	46 ~ 60 (Band: 2 GHz)	Schottky Diode mixer	6.5	-9.5	0
This work	40 ~ 60 (full U-band)	Schottky	4.1 ~ 9.6	-18 ~ -4	6
	40 ~ 52 (half U-band)	Diode mixer	4.1 ~ 6.2	-18 ~ -8.2	6

6. CONCLUSION

In this paper, a millimeter-wave wideband balance mixer with a novel IF block is designed and measured. Firstly, a low loss, wideband and compact suspended stripline IF block which saved the size of the mixer and the LO power is proposed and verified. This block might have application in multipliers, switches or wideband filters. Secondly, substitution method for impedance matching is applied to reduce the RF port reflection. The measured return loss of the mixer shows good agreement with simulated data, and then other parameters are measured and compared to those millimeter-wave mixers listed in Table 3.

ACKNOWLEDGMENT

The work is supported by the Fund of PLA General Armament Department (9140A07050309DZ0233) of China.

REFERENCES

1. Mass, S. A., *Nonlinear Microwave and RF Circuits*, 2nd Edition, Artech House, Boston, 2003.
2. Raghbir, S., T. George, and K. Chang, "Design and performance of W-band broad-band integrated circuit mixers," *IEEE Transactions on Microwave Theory and Techniques*, Vol. 31, No. 3, 277–283, 1983.
3. Schwab, W., F. Boegelsack, and W. Menzel, "Multilayer suspended stripline and coplanar line filters," *IEEE Transactions on Microwave Theory and Techniques*, Vol. 46, No. 7, 1403–1407, 1994.
4. Huynen, I. and G. Dambrine, "A novel CPW DC-blocking topology with improved matching at W-band," *IEEE Microwave and Guide Wave Letters*, Vol. 8, No. 4, 149–151, 1998.
5. Strassner, B. and K. Chang, "New wide-band DC-block cymbal bandpass filter," *IEEE Transactions on Microwave Theory and Techniques*, Vol. 50, No. 5, 1431–1432, 2002.
6. Uysal, S. and L. Lee, "Ku-band double-sided suspended substrate microstrip coupled-line bandpass filter," *Electronics Letters*, Vol. 35, No. 13, 1088–1090, 1999.
7. Menzel, W., M. S. Tito, and L. Zhu, "Low-loss ultra-wideband (UWB) filters using suspended stripline," *Asia Pacific Microwave Conference*, 2148–2151, 2005.
8. Chen, Y., Y. Guo, M. Zhan, and R. Xu, "A broadband suspended stripline bandpass filter," *IEEE International Symposium on Microwave, Antenna, Propagation and EMC Technologies for Wireless Communications*, 804–806, 2009.
9. Zhao, W., Y. Zhang, M. Zhan, Y. Chen, and R. Xu, "A simple method for millimeter-wave finline balanced mixer design using three-dimensional field simulation software," *Journal of Infrared, Millimeter, and Terahertz Waves*, Vol. 33, No. 1, 25–35, 2012.
10. Hislop, A. and R. T. Kihm, "A broad-band 40–60 GHz balanced mixer," *IEEE Transactions on Microwave Theory and Techniques*, Vol. 24, No. 1, 63–64, 1976.
11. Menzel, W. and H. Callsen. "Integrated fin-line components and subsystems at 60 and 94 GHz," *IEEE Transaction on Microwave Theory and Techniques*, Vol. 31, No. 2, 142–146, 1983.
12. Thiel, W. and W. Menzel, "Full-wave design and optimization of mm-wave diode-based circuits in finline technique," *IEEE Transaction on Microwave Theory and Techniques*, Vol. 47, No. 12, 2460–2466, 1999.

13. Chapman, M. W. and S. Raman, "A 60 GHz uniplanar MMIC 4x sub-harmonic mixer," *IEEE International Symposium Digest on Microwave Theory and Techniques*, 95–98, 2001.
14. Dong, Y., R. Bai, J. Xu, and L. Xue, "Wideband sub-harmonic mixer in bilateral finline at U-band," *International Conference on Microwave and Millimeter Wave Technology*, 850–853, 2008.
15. HXI, LLC. Product Datasheet, <http://www.hxi.com/htdocs/prodserve/pdfs/HBM-RevH.pdf>.
16. Tounsi, M. L., R. Touhami, A. Khodja, and M. C. E. Yagoub, "Analysis of the mixed coupling in bilateral microwave circuits including anisotropy for MICs and MMICs applications," *Progress In Electromagnetics Research*, Vol. 62, 281–315, 2006.
17. Kuo J.-T. and E. Shih, "Wideband bandpass filter design with threeline microstrip structures," *Microwaves, Antennas and Propagation, IEE Proceedings*, Vol. 149, No. 56, 243–247, 2002.
18. Zhong, H., R. Xu, and M. Zhan, "Design for Ka-band wideband bandpass filter with three-line microstrip structures," *International Conference on Microwave and Millimeter Wave Technology*, Vol. 1, 351–353, 2008.
19. Zhan, M., Q. Xu, W. Zhao, et al. "Planar W-band mixer with a novel IF-block," *Progress In Electromagnetics Research C*, Vol. 21, 205–215, 2011.