

## NULL STEERING BEAMFORMER USING HYBRID ALGORITHM BASED ON HONEY BEES MATING OPTIMISATION AND TABU SEARCH IN ADAPTIVE ANTENNA ARRAY

O. Kaid Omar<sup>1, \*</sup>, F. Debbat<sup>2</sup>, and A. Boudghene Stambouli<sup>3</sup>

<sup>1</sup>National Institute of Telecommunications and Information and Communication Technologies, INTTIC, Oran, Algeria

<sup>2</sup>University of Mascara, Algeria

<sup>3</sup>University of Sciences and Technology of Oran, Algeria

**Abstract**—In this article, a new hybrid algorithm based on Honey Bees Mating Optimization (HBMO) combined with the Tabu Search (TS) for null steering beamformer in adaptive antenna array is presented. The proposed method HBMO/TS is applied to a set of random cases to estimate the excitation weights of an antenna array that steer the main lobe towards a desired signal, place nulls towards several interference signals and achieve the lowest possible value of side lobe level. Moreover, the proposed algorithm is tested and compared with two other well-known approaches that are the Least Mean Squares (LMS) and Genetic Algorithm (GA). The abovementioned methods have been performed considering uniform linear antenna array and achieved by controlling only the phase of each array element. Results obtained prove the effectiveness of our proposed approach HBMO/TS.

### 1. INTRODUCTION

The techniques of introducing nulls in the antenna patterns to suppress interference and maximizing their gain in the direction of desired signal have received considerable attention in the past and are still of great interest using evolutionary algorithms such as genetic algorithms (GA) [1–3], particle swarm optimization (PSO) [4–12], Taguchi's optimization method [13] or the sequential quadratic

---

*Received 7 June 2012, Accepted 9 August 2012, Scheduled 14 August 2012*

\* Corresponding author: Omar Kaid Omar (omarkaidomar@gmail.com).

programming (SQP) algorithm [14]. In this article, an interference rejection approach, based on an optimization method called HBMO in combination with TS is studied and developed. This approach allows a statistical exploration and research of the optimal power supply of adaptive patch antenna, under the constraint that only the phases of beamforming coefficients are adjustable. HBMO method was presented for the first time in 2001 [15], and since used in various applications such as in [16–22]. In addition to HBMO applications, a so called Artificial Bee Colony (ABC) algorithm is also proposed as a mean for solving optimization problems [23].

This article also assesses the effectiveness of the hybrid algorithm HBMO/TS for the rejection of interference by ordering only the supply phase. We first start detailing our approach HBMO which is based upon the mating process of queens in honey bees. The principle of adaptation and optimization of an antenna array is then presented. Explanation and details of the progress of our algorithm HBMO/TS are made by giving the appropriate model and presenting all its parameters.

## 2. ORIGINAL HBMO ALGORITHM

During the first three days of life of honey bees, the queens cannot fly. From the fifth to the fifteenth day after its birth, the queen, in favorable weather, makes one or more flight tracking and coupling. Fertilization of the queen bees by males takes place outside the hive and in the air. The queen is fertilized by several males until her spermatheca is properly filled. Her tracking period can take several days. The number of copulations appears to be an average of eight but this may vary according to season and mature males availability. Eight to ten males are sometimes necessary for the fertilization of a single queen. After the nuptial flight the queen returns to the hive, the sperm will be kept in her spermatheca and will ensure the fertilization of eggs for the lifetime of the queen. Before the mating process begins, the user must define a number  $\eta_{sp}$  corresponding to the size of the spermatheca of the queen. This number is the maximum number of mating of the queen in one nuptial flight. Whenever the queen mates successfully, the genotype of the drone is stored and a variable is increased by one until the size of the spermatheca is reached. Two more parameters must be defined, the number of queens and the number of broods that will be born by the queen. In this implementation of the HBMO algorithm, the number of queens is equal to one since, in real life, one queen can survive within the hive, the number of broods being the number corresponding to the size of the queen spermatheca. Now we are ready

to begin the mating flight of the queen. At the beginning of the flight, the queen is initialized with some energy content and return to its hive when the energy is within a certain threshold from zero to the value of the spermatheca [22]. The mating of the queen with the drone takes place with a certain probability distribution defined as [15]:

$$\text{Pro}(D) = \exp\left(-\frac{\Delta(f)}{S(t)}\right) \quad (1)$$

where  $\text{Prod}(D)$  is the probability of successful mating, otherwise, the probability of adding the drone's sperm in the spermatheca of the queen.  $\Delta(f)$  is the absolute value of the difference between the fitness function of the drone and the fitness function of the queen.

$$\Delta(f) = |f(D) - f(Q)| \quad (2)$$

$S(t)$  and  $E(t)$  are the speed and the energy of the queen.

$$S(t+1) = \alpha * S(t) \quad (3)$$

and

$$E(t+1) = \alpha * E(t) \quad (4)$$

$\alpha$  is the reducing factor of energy and speed after each transition ( $\alpha$  is within the interval  $[0, 1]$ ). The probability of successful mating is high when the speed of the queen is at a high level or when the fitness function of the drone is approximately equal to that of the queen.

### 3. OPTIMIZATION PRINCIPLE OF AN ANTENNA ARRAY

An antenna array is a set of antennas, arranged in a particular and specific geometry and intended to send or received similar frequency. The advantage of using antenna arrays rather than one source lies in the fact that the element has a single fixed radiation in space (unless it is rotated mechanically) by having multiple sources radiating into space, and by weighting each of these elements, you can vary and change the delays between signals from different antennas to obtain a spatial distribution of radiated power using variable weighting of supply law. The selection process is done by adaptation algorithms that construct reference signals from a predetermined knowledge of the structure of communication signals or apportion of transmitted data [24–26]. Figure 1 shows the basic concept of an adaptive antenna array. The responses of individual sources in the network are then combined by appropriate treatment in order to extract the useful signal. Any variation in complex weights  $w_i$  leads to a new network response. Indeed, the gain of the network, compared to the

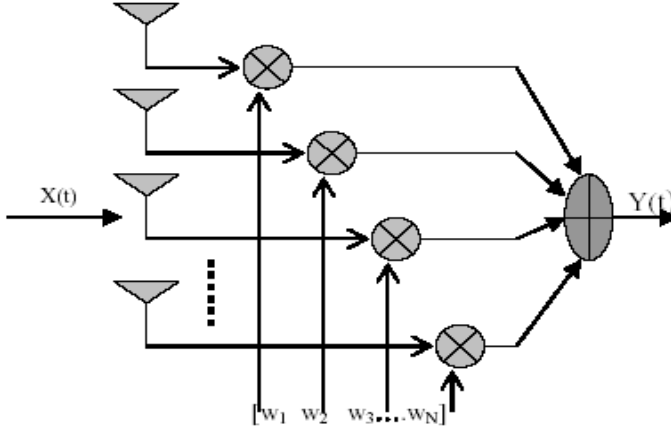

**Figure 1.** Narrow band antenna array with a complex weight.

incident direction of the wave front is easily adjustable by changing the magnitude and phase of signals from different antennas before summing.

If we consider an adaptive network subject to the interference, the problem can be treated in the same way as in the case of the synthesis of antenna array. The directions of incidence of the different sources are known, as the case dealt within this article, we can choose to direct the radiation pattern of zeros in the directions interfering while focusing the direction of incident of useful source [26].

Several topologies exist for adaptive network of antenna. However, this article treats the case of the linear network (a linear array of  $N$  uniform elements). We recognize that there is no coupling between the sources, and each source in the presence of remaining ones radiates the same field. The total field is given by:

$$F(\theta) = f(\theta) \sum_{i=0}^{N-1} w_i \exp(jk_0 i d \sin \theta \cos \varphi) \quad (5)$$

With

$$w_i = a_i \exp(-jb_i) \quad (6)$$

By replacing  $w_i$  in Equation (5), the resulting final equation will be:

$$F(\theta) = f(\theta) \sum_{i=0}^{N-1} a_i \exp(jk_0 i d \sin \theta \cos \varphi + b_i) \quad (7)$$

$\theta$  and  $\varphi$  are direction angles of the sources;  $a_i$  and  $b_i$  are respectively the magnitude of the supply and the phase power of the antenna array;  $d$  is the spacing between the elements in the antenna,  $f(\theta)$  being the field of an antenna element of the network (it is the same for all elements) and  $k_o$  is the wave number. The principle of adapting the antenna array is to determine the complex weighting of power that places zeros in the directions of interference, in order words, find the values of  $a_i$  and  $b_i$ . The approach using the HBMO algorithm to adapt the antenna array is to set the magnitude of the phase that minimizes the maximum radiation levels in the directions of interferences. The link between HBMO algorithm and the problem of adapting antenna array is achieved by the following fitness function:

$$\text{fitness} = 20 \log_{10} \left[ S_d |F(\theta_d)| + \sum_{int=1}^M S_{int} |F(\theta_{int})| \right] \quad (8)$$

With

$$S_d = |S_d(t)| \exp(-j\theta_d) \quad (9)$$

$$S_{int} = |S_{int}(t)| \exp(-j\theta_{int}) \quad (10)$$

$M$  represents the number of interferences;  $S_d$  and  $S_{int}$  are, respectively, the spatial signatures of the desired signal and the interfered signal;  $\theta_d$  and  $\theta_{int}$  are, respectively, the direction of arrival of the desired signal and the interfered signal.

The fitness can then be expressed by:

$$\text{fitness} = 20 \log_{10} \sum_{i=1}^{M+1} S_i |F(\theta_i)| \quad (11)$$

With

$$S_i = S_d + S_{int} \quad (12)$$

Moreover, by replacing  $F(\theta)$  in Equation (11), the resulting final equation will be:

$$\text{fitness} = 20 \log_{10} \left[ \sum_{i=1}^{M+1} S_i f(\theta_i) \sum_{n=1}^N a_n \exp(jk_0 n d \sin \theta_n \cos \varphi_n + b_n) \right] \quad (13)$$

$S_i$  is the vector space of the sources.

#### 4. OPTIMIZATION OF THE ANTENNA ARRAY

In this section we present and explain in details three different methods of optimization of the antenna array using the following algorithms: HBMO/Ts, GA and LMS. GA and LMS are being added for a comparison purpose and in the view of improving our proposed approach.

#### 4.1. Using the Hybrid Algorithm HBMO/TS

After initializing HBMO/TS parameters, we randomly generate a set of solutions (population of bees). Each solution represents a vector phase of the antenna array. The evaluation and ranking are based on the values of the fitness function (Equation (13)). The best solution (optimal phase) is considered as the queen and the remaining solutions as the drones. The Mating, which is the coupling of the queen with the drones, generates new solutions called the Broods. Each crossover operation takes place according to the probability  $Pro(D)$  (Equation (1)). The crossover process will be done by permutation between elements of the queen vector and the drone vector. The choice of these elements of permutation is done randomly. We test every time the feasibility of the solution which should belong to the research space. After each mating, an update of the spermatheca, speed and energy of the queen is done systematically. The mating is stopped when one of the stopping criteria (size of the spermatheca  $\eta_{sp}$ , final energy  $E_f$  or final speed  $S_f$ ) is reached. After the mating step, we use the workers to improve the generated solutions named Broods. The workers are based on TS that will be part of the algorithm HBMO hence the name hybrid approach HBMO/TS. The overall approach is to modify iteratively an initial solution, hoping to reach a final acceptable solution in a reasonable time. To this end, the method uses tabu movements to move from one solution to another within a predefined search space. TS strategy is to generate from an initial solution (solution brood) a set of neighboring solutions throughout research space. The starting solution and every solution in the neighborhood represent a phase vector with  $n$  unknowns ( $n$ : number of antennas). Each component of this vector is in the range  $[-\pi/2, \pi/2]$  (lower and upper bounds of research space). The neighboring solutions are determined by the application of a research movement in the vicinity of the starting solution given by the following expression:

$$X_{k+1} = X_k + g(X_k) \quad (14)$$

$X_k$  represents the current vector phase and  $X_{k+1}$  the neighbor vector phase and  $k$  number of iterations of this process. The stochastic transformation function is determined experimentally with  $r$  being a random variable within the interval  $[-1, 1]$ .

$$g(X_k) = X_k + (2r_1 - 0.5)/100 \quad (15)$$

At each iteration, we retain the best phase vector neighbor which becomes the starting solution for the next iteration. The evaluation of phase vectors is done accordingly to the criterion of minimizing the "objective" function (Equation (13)). Avoid the risk of recycling since

the algorithm needs a memory to store the latest best solutions already visited (tabu list). In applying the suction criterion of the tabu search, we choose the best phase vector found during this process (even if this solution belongs to the tabu list). This vector will represent the brood phase improved by the workers.

After phase improvement by workers, we repeat the evaluation and ranking of broods improved and the best solution is compared with the queen. If it brings an improvement in the value of fitness, the queen will be replaced by this solution; otherwise, we keep the queen. The overall process, which is the optimization of antenna array based on HBMO/TS, happens indefinitely until reaching a stopping criterion defined by a number of iterations.

The following steps summarize the HBMO/TS algorithm.

- i. HBMO Parameters initialization.
  - $\eta_{sp}$ : Size of the spermatheca.
  - $E(t)$  et  $S(t)$ : Energy and Speed (Energy and Speed are within the interval  $[0.5, 1]$ ).
  - $\alpha$ : reducing factor of energy and speed ( $\alpha$  is within the interval  $[0, 1]$ ).
  - $M$ : maximum number of mating flights.
- ii. Generate the initial population of the bees (random strategy).
- iii. Evaluate and ranking Bees Fitness function.
- iv. Select the best solution of the population of phase vector which represents the queen.
- v. For  $i = 0$  to  $M$  ( $M$ : number of mating flights).
  - do while  $E(t) > E_{\min}$  or  $S(t) > S_{\min}$  or Sperm is not full (Sperm  $\neq \eta_{sp}$ ).
    - Select a drone.
    - if the drone passes the probabilistic condition.
      - do the Mating (cross between drone and queen  $\rightarrow$  Generate a brood).
      - Add brood to the list of broods.
      - Add drone sperm in the spermatheca (update sperm).
  - endif
    - $S(t + 1) = \alpha \times S(t)$ .
    - $E(t + 1) = \alpha \times E(t)$ .
  - Enddo
    - Improve the brood's fitness by applying the workers improve ( ) (Tabu search based).
    - if the brood's fitness is better than the queen's fitness.
      - Replace the queen with the brood.
      - else Add the brood to the population of drones.

endif

- vi. Update the drone population (Replace the weak drones by the best broods).  
    enddo (for)
- vii. return The Queen (Best Solution).

The procedure of workers improve based on Tabu Search is presented by the following algorithm.

workers\_improve ( ): Tabu search

- i. Begin
  - Initial solution  $s$  (brood found which will be improved);
  - Insert  $s$  in the tabu List;
- ii If  $F(s) < F(S_{\max})$  then  $S_{\max} \leftarrow s$ . { $S_{\max}$ : the best solution} While (Criterion of stop not checked)
  - Generate the neighborhood of the current solution
  - Select  $s'$  in this neighborhood although  $s'$  is not present in the tabu list.
  - $S_{\max} \leftarrow s'$  {minimize the fitness as seen in Equation (13)}
  - Update the tabu list
  - End if
  - End while
- iii. End.

#### 4.2. Using Genetic Algorithm (GA)

The variables to be optimized are represented by genes; genes set being considered as an individual. By analogy with our problem, the genes are the  $b_n$  and the individual is the set of the vector  $b$  of  $N$  elements. We use a 16-bits coding to increase the accuracy of calculation of the phase law.

The first step in the genetic algorithm is to generate an initial population as a binary matrix of  $L$  rows and  $C$  columns, in that  $L$  is the number of individuals in the population and  $C$  is the number of genes. This latter having the individual equal to the number of elements, that is to say,  $N$  times the number of bits in the binary encoding used. We evaluate the strength of individuals in the population by calculating the fitness of each individual (each line of the initial matrix). This is done by decoding the chromosome for each individual. The following formula is being used for decoding chromosomes:

$$b = \frac{P_{\max} + P_{\min}}{2^N} \sum_{i=0}^{N-1} 2^i P_i + P_{\min} \quad (16)$$



$P_{\max}$  and  $P_{\min}$  are respectively the upper and lower bounds of the interval of variation of the two phases.  $P_i$  is the  $i$ th bit of the chromosome to be decoded. The vector  $b$  obtained is then used to calculate the fitness function for this individual. The GA is a maximizer by default, and as we seek to minimize the radiation level, we apply the following formula:

$$\text{Fitness} = \text{Max} - \text{fitness} \quad (17)$$

Max is a positive real number of high value (larger than the maximum of all values of the fitness function). From this stage, operators of the genetic algorithm will be involved in the reproduction of populations by operations: selection, classification, crossover and mutation. Note that these operators are performed on the population in binary code. The dimensions of the original matrix must be maintained after each operator. The last population of individuals obtained is called a generation. It is composed of individuals better than the original population. However, this is not enough to achieve good results. The four operations must be repeated as much as a determined number of generations is not reached or until the genetic algorithm does not converge to an optimal individual.

### 4.3. Using the Least Mean Square (LMS)

The LMS is based on the gradient method, which calculates and updates the weights recursively. We show that the error is a quadratic form of weights and, intuitively, the optimal solution is obtained by correcting step by step the weight vector in the direction of minimum [27].

## 5. SIMULATION AND RESULTS

The method of adapting antenna array by the hybrid algorithm HBMO/TS has been programmed in Matlab. We considered a linear printed antenna array of 10 evenly spaced elements of  $\lambda/2$  on which several measures were conducted. The antenna array is first fed uniformly in phase and magnitude. In order to apply our algorithm, we need to define initialization parameters as shown in Table 1.

In the first step, we applied our algorithm directly to different measures of rejections. We note that in all cases (Figures 2(a), (b) and (c)) the radiation pattern does not undergo any degradation in the coverage area of the signal and rejections are always in the direction of interferences. Levels of interferences rejections are remarkably low in the order of  $-118$  dB (Figure 2(a)) for rejection localised at  $6^\circ$

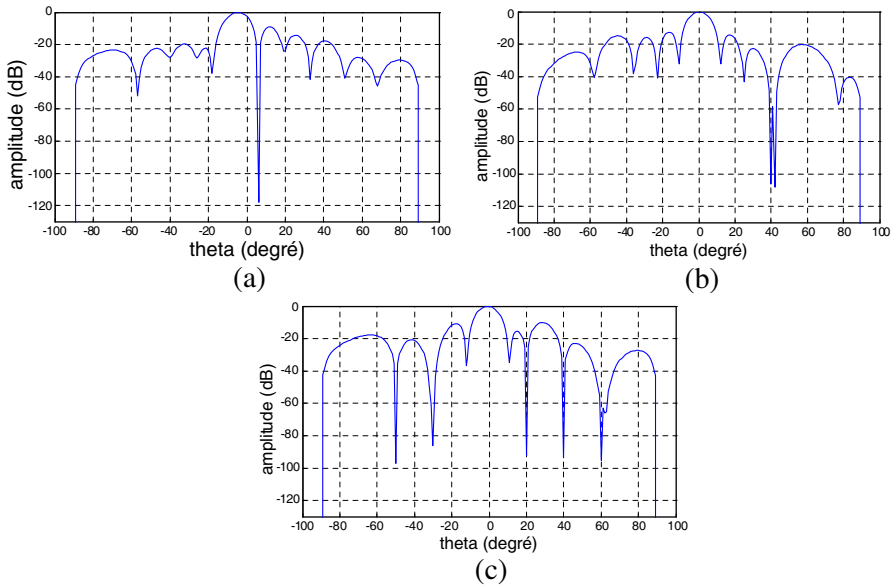

**Figure 2.** Interferences rejections by HBMO/TS: (a) interference rejection in the direction of the main lobe at  $6^\circ$ , (b) two very close interferences rejections at  $40^\circ$  and  $42^\circ$ , (c) the case of several interferences rejections (interferences at  $-50^\circ$ ,  $-30^\circ$ ,  $20^\circ$ ,  $40^\circ$ ,  $60^\circ$ ).

**Table 1.** Parameters of the HBMO/TS approach.

HBMO parameters	TS parameters
Number of Queen: 1	Tabu list size: 10
Number of drones: 40	Number of iterations: 100
Number of Mating Flights: 20	Type of neighborhood: stochastic
Size of Queen Sparmatheca $\eta_{sp} = 20$	processing in neighborhood space
Number of Broods: 20	$g(X_k)$
Number of Workers: 1	
A decay rate: 0.9	
Speed and Energy randomly in $[0.5, 1]$	
Number of iterations for general algorithm: 10	

**Table 2.** Parameters of the genetic algorithm.

GA parameters
Initial population size: 50
Number of generation: 30
Probability of crossover: 0.7
Mutation probability: 0.2
Type of crossing: Crossing to a single point
Type of coding: Binary encoding

(very close to the direction of the useful signal) and in the order of  $-106$  dB (Figure 2(b)) for two closed rejections. Figure 2(b) shows clearly the accuracy of the two closely located interferences rejections at respectively  $40^\circ$  and  $42^\circ$ . In the case of multiple interferences, the level of rejection varies from  $-86$  dB to  $-98$  dB (Figure 2(c)). The side lobe level is reduced; it ranges from  $-15$  dB to  $-30$  dB for the different cases of simulation. It can be concluded that the HBMO/TS method provides a significant improvement on the levels of interferences rejection above  $-85$  dB and reach very low levels up to  $-106$  dB and  $-118$  dB.

In the second step, we perform a comparison between our method and two other well-known approaches that are the Least Mean Squares (LMS) and Genetic Algorithm (GA) which are probably the most common used and many articles are taking them as a references. These approaches have also been programmed in Matlab. In order to apply our algorithms, we need to define initialization parameters of GA as shown in Table 2.

In the case of a rejection located at  $45^\circ$  (Figure 3(a)), the hybrid method and LMS give a better result (more than  $-105$  dB) compared to the GA ( $-80$  dB). Regarding the rejection of two very closed interferences at  $17^\circ$  and  $20^\circ$  of Figure 3(b), the rejection level is between  $-95$  dB and  $-108$  dB for HBMO/TS and less than  $-62$  dB for the LMS and GA case.

As for several interferences, the GA shows a very low rejection levels at between  $-56$  dB and  $-65$  dB. The LMS method is seen to be ineffective when the number of rejections is greater than two. Figure 3(c), case of three interferences rejections at  $-30^\circ$ ,  $20^\circ$  and  $40^\circ$ , shows clearly that the resulted rejection are shifted towards new values such as  $-35$ ,  $22$  and  $52$  instead of  $-30$ ,  $20$  and  $40$  as reached by the HBMO/TS method. However, the hybrid method gives better satisfying results (the rejection levels are situated between  $-92$  dB and  $-101$  dB). We notice that the results achieved by the HBMO/TS are

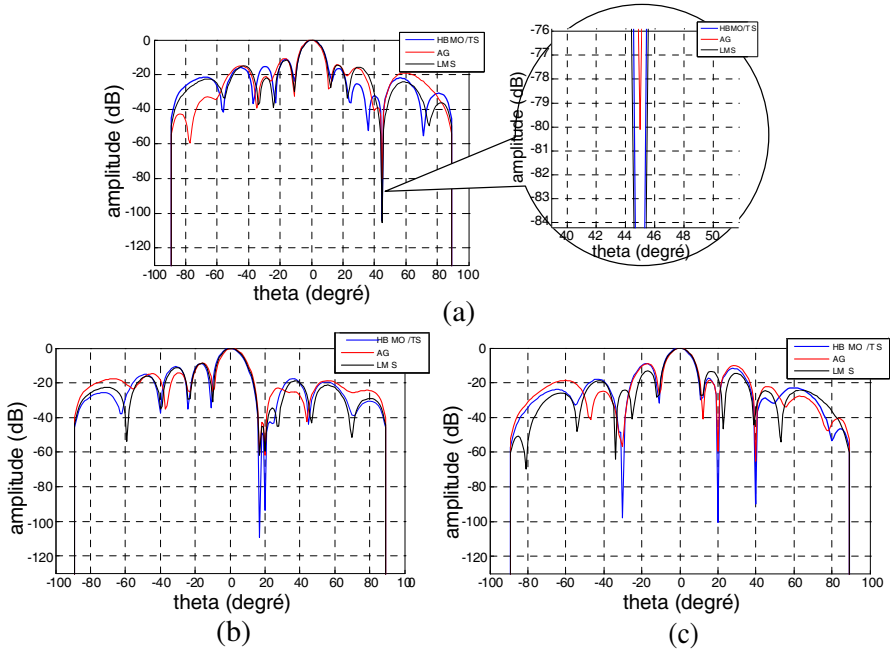

**Figure 3.** Interferences rejections: (a) interference rejection at  $45^\circ$ , (b) two very close interferences rejections ( $17^\circ$  and  $20^\circ$ ), (c) several interferences rejections (at  $-30^\circ$ ,  $20^\circ$  and  $40^\circ$ ).

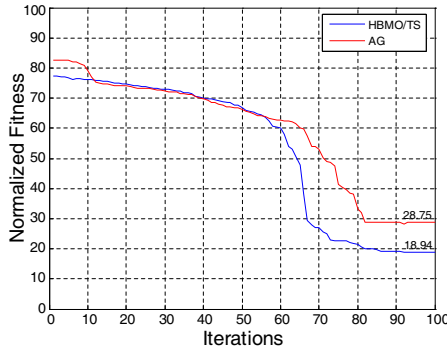

**Figure 4.** Comparative graphs showing the evolution of the fitness function in the case of one interference rejection at  $45^\circ$  for HBMO/TS and AG.

much better than the ones seen when using LMS and GA methods.

The phases of antenna elements are computed as given in Table 3. Phase values are calculated from the three different scenarios and in each case of interferences rejection. We notice that HBMO/TS and

**Table 3.** Phase values in all cases of interferences rejection and for all scenarios HBMO/TS, AG and LMS.

Interferences Rejection at Phase(°)	HBMO/TS			AG			LMS		
	45°	20° and 17°	40°, 20° and -30°	45°	20° and 17°	40°, 20° and -30°	45°	20° and 17°	40°, 20° and -30°
Phase 1	9.29	-18.77	28.32	71.81	18.96	81.50	-35.65	25.95	-13.48
Phase 2	43.02	44.10	34.26	69.16	87.04	69.69	-25.27	79.44	-19.94
Phase 3	20.94	44.14	28.10	62.51	37.71	72.72	-43.52	81.43	-25.19
Phase 4	15.83	22.07	67.17	67.63	66.68	120.00	-31.21	63.30	13.17
Phase 5	14.97	25.83	64.09	52.36	47.26	89.98	-27.86	54.96	-7.03
Phase 6	2.33	18.47	16.71	56.42	28.90	66.57	-61.02	51.65	-28.66
Phase 7	6.97	21.46	21.57	69.16	15.77	42.22	-53.35	44.74	-22.49
Phase 8	14.70	-11.17	46.85	70.16	5.79	81.04	-26.27	25.02	-10.49
Phase 9	-1.29	2.35	57.09	62.21	12.85	95.03	-54.26	28.15	-15.74
Phase 10	34.56	56.48	48.65	91.02	48.77	73.96	-35.78	81.42	-22.19

LMS phase values are within the interval  $[-\frac{\pi}{2}; \frac{\pi}{2}]$  and AG phase values are within the interval  $[0; \pi]$ .

A comparison in terms of convergence among the HBMO/TS and AG is made. We observe, in Figure 4, that the HBMO/TS converges a little slower than AG but it finally achieves better fitness values (18.94 for HBMO/TS and 28.75 for AG).

## 6. CONCLUSION

Our hybrid approach combining HBMO and TS presents satisfactory results with respect to the interferences rejections. We obtained very low levels rejections having good accuracy even in the case of multiple interferences. In comparison with the two other well-known approaches that are the Least Mean Squares (LMS) and Genetic Algorithm (GA), we observed the effectiveness of our approach HBMO/TS. This could be a reliable method for the rejection of several interferences. One might consider using it for other types of network architectures (network plan, conformal network) and in contexts of more specific applications such as satellite communications and mobile networks.

## REFERENCES

1. Chung, Y. C. and R. L. Haupt, "Amplitude and phase adaptive nulling with a genetic algorithm," *Journal of Electromagnetic Waves and Applications*, Vol. 14, No. 5, 631–649, 2000.
2. Mahanti, G. K., A. Chakrabarty, and S. Das, "Phase-only and amplitude-phase synthesis of dual-pattern linear antenna arrays using floating-point genetic algorithms," *Progress In Electromagnetics Research*, Vol. 68, 247–259, 2007.
3. Caorsi, S., F. DeNatale, M. Donelli, D. Franceschini, and A. Massa, "A versatile enhanced genetic algorithm for planar array design," *Journal of Electromagnetic Waves and Applications*, Vol. 18, No. 11, 1533–1548, 2004.
4. Rocca, P., M. Donelli, A. Massa, and D. Franceschini, "Three-dimensional microwave imaging problems solved through an efficient multiscaling particle swarm optimization," *IEEE Trans. on Geoscience and Remote Sensing*, Vol. 47, 1467–1481, 2009.
5. Azaro, R., F. DeNatale, M. Donelli, E. Zeni, and A. Massa, "Synthesis of a prefractional dual-band monopolar antenna for GPS applications," *IEEE Antennas and Wireless Prop. Letters*, Vol. 5, No. 9, 361–364, 2006.
6. Li, W.-T., X.-W. Shi, and Y.-Q. Hei, "An improved particle swarm optimization algorithm for pattern synthesis of phased arrays," *Progress In Electromagnetics Research*, Vol. 82, 319–332, 2008.
7. Boeringer, D. W. and D. H. Werner, "Particle swarm optimization versus genetic algorithms for phased array synthesis," *IEEE Transactions on Antennas and Propagation*, Vol. 52, 771–779, Mar. 2004.
8. Mahmoud, K. R., M. El-Adawy, S. M. M. Ibrahim, R. Bansal, and S. H. Zainud-Deen, "A comparison between circular and hexagonal array geometries for smart antenna systems using particle swarm optimization algorithm," *Progress In Electromagnetics Research*, Vol. 72, 75–90, 2007.
9. Lanza, M., J. R. Pérez, and J. Basterrechea, "Synthesis of planar arrays using a modified particle swarm optimization algorithm by introducing a selection operator and elitism," *Progress In Electromagnetics Research*, Vol. 93, 145–160, 2009.
10. Pérez, J. R. and J. Basterrechea, "Hybrid particle swarm-based algorithms and their application to linear array synthesis," *Progress In Electromagnetics Research*, Vol. 90, 63–74, 2009.
11. Zaharis, Z. D. and T. V. Yioultis, "A novel adaptive beamforming technique applied on linear antenna arrays using adaptive mutated

- boolean PSO,” *Progress In Electromagnetics Research*, Vol. 117, 165–179, 2011.
12. Zaharis, Z. D., K. A. Gotsis, and J. N. Sahalos, “Adaptive beamforming with low side lobe level using neural networks trained by mutated boolean PSO,” *Progress In Electromagnetics Research*, Vol. 127, 139–154, 2012.
  13. Dib, N. I., S. K. Goudos, and H. Muhsen, “Application of Taguchi’s optimization method and self-adaptive differential evolution to the synthesis of linear antenna arrays,” *Progress In Electromagnetics Research*, Vol. 102, 159–180, 2010.
  14. Mouhamadou, M., P. Vaudon, and M. Rammal, “Smart antenna array patterns synthesis: Null steering and multi-user beamforming by phase control,” *Progress In Electromagnetics Research*, Vol. 60, 95–106, 2006.
  15. Abbass, H. A., “Marriage in honey bees optimization (MBO): A haplometrosis polygynous swarming approach,” *The Congress on Evolutionary Computation, CEC*, 207–214, 2001.
  16. Bozorg Haddad, O., A. Afshar, and M. A. Mariño, “Honey-bees mating optimization (HBMO) algorithm: A new heuristic approach for water resources optimization,” *Water Resources Management*, Vol. 20, 661–680, 2006.
  17. Mohammad, F., A. Babak, and M. Ali, “Application of honey-bee mating optimization algorithm on clustering,” *Applied Mathematics and Computations*, 1502–1513, 2007.
  18. Amiri, B. and M. Fathian, “Integration of self organizing feature maps and honey bee mating optimization algorithm for market segmentation,” *Journal of Theoretical and Applied Information Technology*, 70–86, 2007.
  19. Fathian, M. and B. Amiri, “A honey bee mating approach for cluster analysis,” *International Journal of Advance Manufacturing and Technology*, Vol. 38, 809–821, 2008.
  20. Shayegi, H., H. A. Shayanfar, A. Jalili, and A. Ghasemi, “LFC design using HBMO technique in interconnected power system,” *International Journal on Technical and Physical Problems of Engineering (IJTPE)*, Vol. 2, 41–48, 2010.
  21. Niknam, T., “A new HBMO algorithm for multiobjective daily Volt/Var control in distribution systems considering distributed generators,” *Applied Energy*, Vol. 88, 778–788, 2011.
  22. Niknam, T., J. Olamei, and R. Khorchidi, “A hybrid algorithm based on HBMO and fuzzy set for multi-objective distribution feeder reconfiguration,” *World Applied Science Journal*, Vol. 4,

- 308–315, 2008.
23. Donelli, M., I. Craddock, D. Gibbons, and M. Sarafianou, “A three dimensional time domain microwave imaging method for breast cancer detection based on an evolutionary algorithm,” *Progress In Electromagnetics Research M*, Vol. 18, 179–195, 2011.
  24. Lehne, P. H. and M. Pettersen, “An overview of smart antenna technology for mobile communications systems,” *IEEE Communications Surveys*, Vol. 2, 2–13, 1999.
  25. Shaukat, S. F., M. Ul Hassan, R. Farooq, H. U. Saeed, and Z. Saleem, “Sequential studies of beamforming algorithms for smart antenna systems,” *World Applied Sciences Journal*, Vol. 6, 754–758, 2009.
  26. Godara, L. C., “Application of antenna arrays to mobile communications, Part II: Beamforming and direction-of-arrival considerations,” *Proc. of the IEEE*, Vol. 85, 1193–1245, Aug. 1997.
  27. Applebaum, S., “Adaptive arrays,” Technical Report SPL TR-66-001, Syracuse University Corporation Corporation Report, 1965.