

Mutual Coupling Reduction of Closely Spaced MIMO Antenna Based on Electric Resonator

Sajjad Abazari Aghdam^{1, *}, Jonathan Bagby¹, and Raul J. Pla²

Abstract—A new technique for mutual coupling reduction, based on the application of electric resonator, is presented in this paper. In this method, first a custom-designed unitcell is presented that provides a proper S_{12} response for the mutual coupling reduction, and then, this unitcell is used in a two-element array of wideband dipoles. According to the results, this unitcell provides a maximum reduction of 15 dB in the frequency response of the antenna array while does not have a considerable effect on the reflection coefficient and radiation pattern of the antenna. To verify the results, the antenna is fabricated and measured, and there is a very good agreement between the simulation and measurement.

1. INTRODUCTION

Today, MIMO antennas are key elements in modern wireless communication systems, because they can minimize the interference, improve the link quality and channel capacity without the need of increasing the bandwidth. One major drawback in designing MIMO antennas is the interactions of electromagnetic wave between the adjacent elements which degrade the antenna parameters such as bandwidth and radiation pattern. To solve this issue, a lot of works have been carried out to decrease the effect of mutual coupling between antennas such as EBG, DGS, as well as metamaterials [1–10]. The above mentioned techniques have been applied to broadside radiation type. For instance, two inverted-L shaped branches and a rectangular slot with one circular end was etched on the ground plane of a folded monopole antenna, which covers different standards suitable for mobile phone applications [11]. With this proposed technique the mutual coupling is better than 15 dB and 20 dB in the lower and upper bands, respectively. However, for some applications it is necessary not to modify the ground plane so as to integrate the antenna element to RF front-end systems. Another approach to minimize the effect of mutual coupling is to integrate arrays of split-ring resonators as a metamaterial inclusion between adjacent elements [12].

Recently, the authors in [13] have presented a compact S-shaped EBG structure to reduce the E -plane mutual coupling between two patch antennas by 15 dB at 5.25 GHz. However, the drawback of this configuration is the use of via which adds complexity to achieve S-shaped configuration. The authors in [14] have introduced three interdigital lines that excite the orthogonal polarization mode for reducing the mutual coupling between adjacent patch antennas. With this method the isolation corresponds to -20 dB. However, using vias in the interdigital lines adds complexity to the antenna configuration. Applying a T-shaped slot impedance transformer between two closely spaced PIFA antennas [15] is another approach with isolations of 19.2 and 22.8 for WLAN and WiMAX frequency bands, respectively. Utilizing the wall loaded by a coplanar strip and defected split-ring resonator is another viable approach to reduce the mutual coupling between closely distanced patch antennas [16].

Received 2 June 2016, Accepted 20 October 2016, Scheduled 11 November 2016

* Corresponding author: Sajjad Abazari Aghdam (sabazariaghd2012@fau.edu).

¹ The authors are with the Department of Computer & Electrical Engineering and Computer Science, University of Florida Atlantic University, Boca Raton, Florida, USA. ² Antenna World Company, Miami, FL, USA.

However, the presence of the wall makes the antenna structure bulky, which is useless for modern wireless communication systems.

In this paper, we propose a simple technique to suppress the effect of mutual coupling between two planar end-fire dipole antennas. The proposed antenna operates in the wide frequency bandwidth of 1.8–4.2 GHz with edge to edge distance of 2 mm. To reduce the interaction between antennas, an array of modified electric resonators is integrated on the back side of the dipole antenna. To verify the results, a prototype of the antenna is fabricated indicating that there is a good agreement between the simulation and measurement. The measured isolation between antennas is below -40 dB over frequency band of 2.15–3.1 GHz, which makes this structure a good candidate for MIMO antenna applications.

2. UNITCELL DESIGN

The geometry in Fig. 1 shows the schematic view of the proposed design for the metamaterial unitcell. This unitcell is implemented on a Rogers RT/5880 substrate with the effective permittivity of 2.2 and thickness of 1.575 mm. To calculate the frequency response of the unitcell, it is simulated in the HFSS software using the PEC and PMC walls along X and Z directions and two ports located in the Y direction, and the S parameter results are plotted in Fig. 2. According to the results, there is a very deep fall-off in the S_{12} response of the unitcell from 2.28 to 3.30 GHz. As mentioned in the previous section, the final objective of this paper is to apply this unitcell on a planar antenna array structure and use its sharp fall-off as a mutual coupling reduction mechanism.

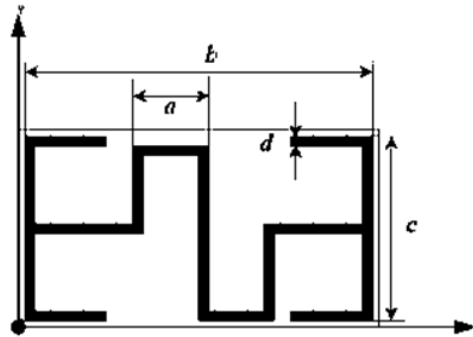

Figure 1. Geometry Schematic view of the unitcell ($a = 2.3$, $b = 10.6$, $c = 5.6$, $d = 0.3$ mm).

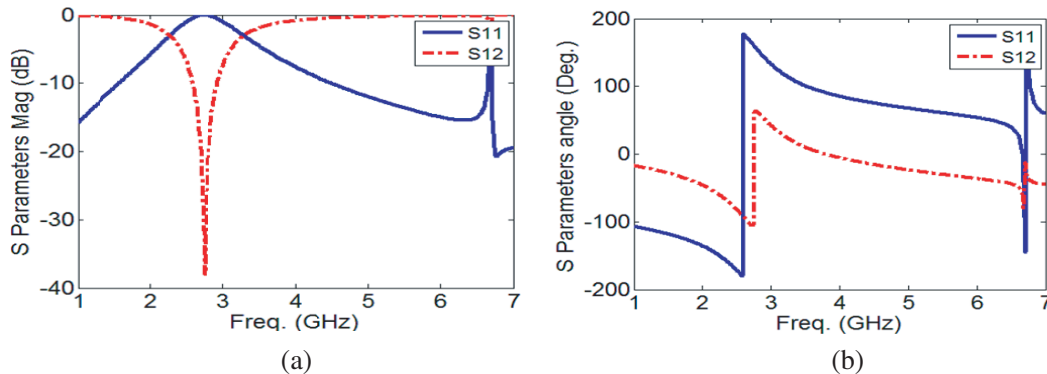

Figure 2. Simulated S -parameters of the unitcell, (a) magnitude and (b) phase.

3. PARAMETRIC STUDY OF THE ANTENNA

Figure 3 depicts the schematic view of the presented antenna array with the unitcells printed as the mutual coupling reduction elements. The reference antenna is derived from [11] where a special balun structure is used to obtain a wideband result. This two-element antenna array is also implemented on the Rogers RT/5880 substrate with the thickness of 1.575 mm. The effect of metamaterial unitcells on the mutual coupling of the antenna is demonstrated in Fig. 4. According to Fig. 4(b), a reduction in S_{12} parameter of the antenna is observed from 1.7 to 3 GHz, and the maximum amount of mutual coupling reduction is 15 dB, which is achieved at the frequency of 2.45 GHz. The other important feature of the metamaterial inclusions in front of antenna is their negligible effect on the antenna matching as demonstrated in Fig. 4(a). According to Fig. 4(a), the metamaterial loading has no effect on antenna reflection coefficient, and the S_{11} parameter is almost the same with and without metamaterial. The antenna gain is 6 dB when the unitcells are used, which is the same as the antenna with no unitcells.

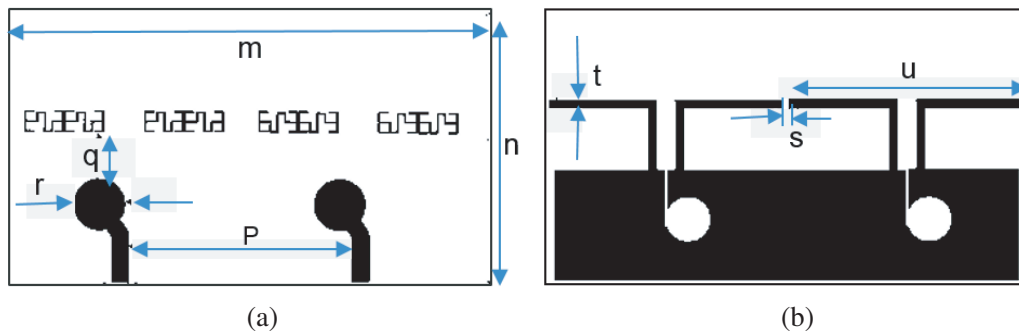

Figure 3. Schematic view of the antenna with unitcells, (a) top, (b) bottom (dimensions in millimeters are: $m = 130$, $n = 71.7$, $p = 60.5$, $q = 12.7$, $r = 13.5$, $s = 1.9$, $t = 2$, $u = 63.1$).

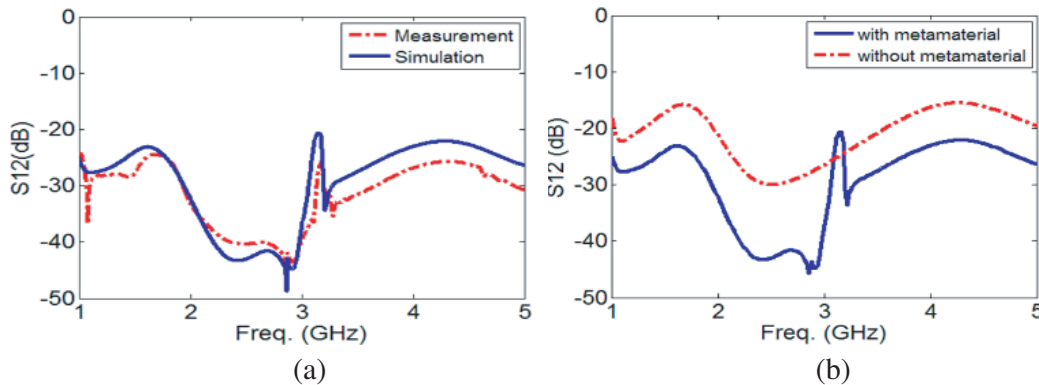

Figure 4. Simulated S -parameters of the antenna, (a) S_{11} and (b) S_{12} .

4. EXPERIMENTAL ANTENNA

To verify the simulation results, the antenna is fabricated and measured. Photographs of the fabricated prototype is shown in Fig. 7.

The measured reflection coefficient and S_{12} of the antenna with the decoupling elements is plotted in Fig. 5, which is in a very close agreement with the simulation results. Moreover, the measured radiation pattern of the fabricated prototype totally complies with the simulation in both E and H planes as depicted in Fig. 6. The radiation patterns of the proposed array antenna were measured in an anechoic chamber at the AntennaWorld Inc. Technology lab in Miami, Florida with Orbit/FR FR959 Antenna Measurement system [17, 18].

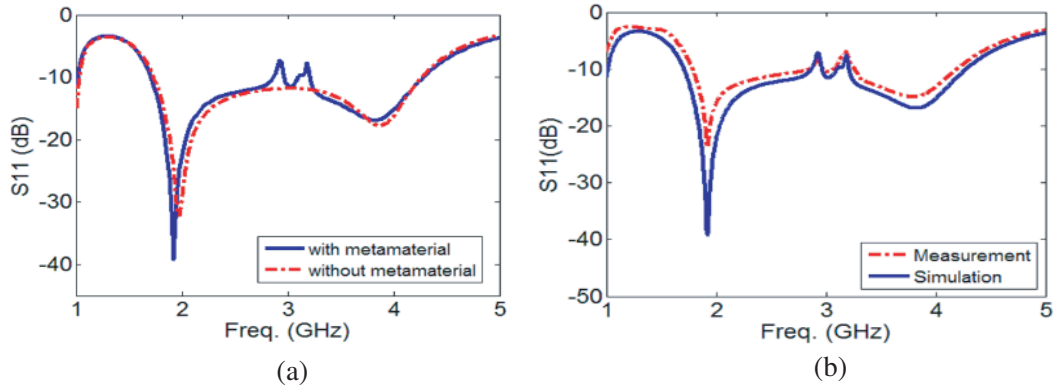

Figure 5. Measured S -parameters of the antenna, (a) S_{11} and (b) S_{12} .

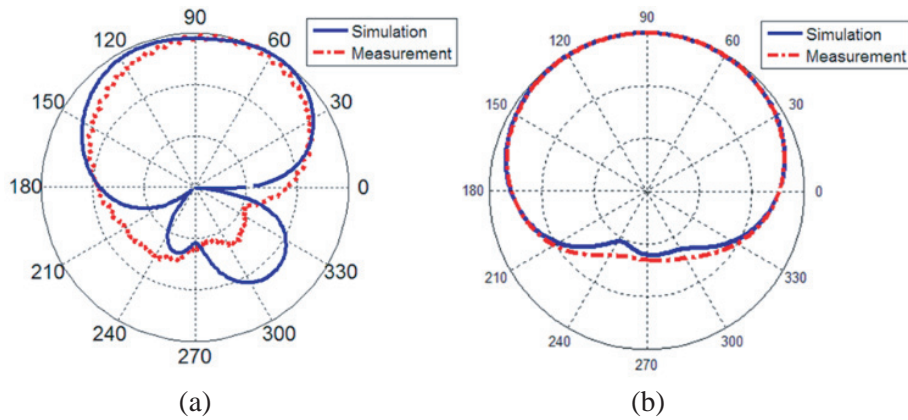

Figure 6. Measured radiation pattern at 2.45 GHz, (a) E -plane, (b) H -plane.



Figure 7. The fabricated prototype, (a) top and (b) bottom.

5. CONCLUSION

In this paper, a new technique for mutual coupling reduction is introduced. In this technique, a special metamaterial unitcell is designed to produce a deep fall-off in the desired frequency range, and then the presented unitcell is used in the structure of a planar two-element antenna array. According to the results, the presented technique leads to a reduction of 15 dB in the S_{12} parameter of the antenna array while not affecting the antenna matching and radiation pattern. A prototype of the antenna array with the embedded unitcells is fabricated, and the measurement results are very close to the simulation. The presented unitcell provides a simple, low-profile and effective method for mutual coupling reduction of antenna arrays and can be used in modern MIMO applications.

ACKNOWLEDGMENT

This work was supported in part by the National Science Foundation (NSF), USA. I would like to thank AntennaWorld Inc. Technology Company for providing us the opportunity to work on this extensive research project, allowing us to utilize research facilities to the best of their capabilities, and providing us the opportunity to use their anechoic chamber facility for antenna measurement analysis.

REFERENCES

1. Yu, A. and X. Zhang, "A novel method to improve the performance of microstrip antenna arrays using a dumbbell EBG structure," *IEEE Antennas Wireless Propag. Lett.*, Vol. 2, 170–172, 2003.
2. Abazari Aghdam, S., "Reconfigurable antenna with a diversity filtering band feature utilizing active devices for communication systems," *IEEE Trans. Antennas Propag.*, Vol. 61, No. 10, 5223–5228, Oct. 2013.
3. Abazari Aghdam, S., "A novel UWB monopole antenna with tunable notched behavior using varactor diode," *IEEE Antennas Wireless Propag. Lett.*, Vol. 13, 1243–1246, 2014.
4. Farahani, H. S., M. Veysi, M. Kamyab, and A. Tadjalli, "Mutual coupling reduction in patch antenna arrays using a UC-EBG superstrate," *IEEE Antennas Wireless Propag. Lett.*, Vol. 9, 57–59, 2010.
5. Abazari Aghdam, S. and J. S. Bagby, "Resonator type for the creation of a potentially reconfigurable filtering band in a UWB antenna," *Progress In Electromagnetics Research Letters*, Vol. 52, 17–21, 2015.
6. Nouri, M. and S. Abazari Aghdam, "Reconfigurable UWB antenna with electrically control for triple on-demand rejection bandwidth," *Microwave and Optical Technology Letters*, Vol. 57, No. 8, 1894–1897, Aug. 2015.
7. Bait-Suwailam, M. M., O. F. Siddiqui, and O. M. Ramahi, "Mutual coupling reduction between microstrip patch antennas using slotted-complementary split-ring resonators," *IEEE Antennas Wireless Propag. Lett.*, Vol. 9, 876–878, 2010.
8. Zarei, V., H. Boudaghi, M. Nouri, and S. Abazari Aghdam, "Reconfigurable circular polarization antenna with utilizing active devices for communication systems," *Applied Computational Electromagnetics Society Journal*, Vol. 30, No. 9, 990–995, Sep. 2015.
9. Karimian, R., H. Oraizi, S. Fakhte, M. Farahani, "Novel F-shaped quad band printed slot antenna for WLAN and WiMAX MIMO system," *IEEE Antennas Wireless Propag. Lett.*, Vol. 12, 405–408, 2013.
10. Karimian, R., M. Soleimani, and S. M. Hashemi, "Tri-bands four elements MMO antenna system for WLAN and WiMAX application," *Journal of Electromagnetic Wave and Application*, Vol. 26, Nos. 17–18, 2348–2357, 2012.
11. Shoaib, S., I. Shoaib, N. Shoaib, X. Chen, and C. G. Parini, "Design and performance study of a dual-element multiband printed monopole antenna array for MIMO terminals," *IEEE Antennas Wireless Propag. Lett.*, Vol. 13, 329–332, 2014.
12. Von, D., B. M. Trindade, C. Müller, M. Cristina, F. De Castro, and F. C. C. D. Castro, "Metamaterials applied to ESPAR antenna for mutual coupling reduction," *IEEE Antennas Wireless Propag. Lett.*, Vol. 14, 430–433, 2015.
13. Veeramani, A., A. S. Arezomand, J. Vijayakrishnan, and F. B. Zarrabi, "Compact S-shaped EBG structures for reduction of mutual coupling," *2015 Fifth International Conference on Advanced Computing & Communication Technologies (ACCT)*, 21–25, IEEE, 2015.
14. Qi, H., X. Yin, L. Liu, Y. Rong, and H. Qian "Improving isolation between closely spaced patch antennas using interdigital lines," *IEEE Antennas Wireless Propag. Lett.*, Vol. 15, 1-1, Jan. 2015.
15. Zhang, S., B. K. Lau, Y. Tan, Z. Ying, and S. He, "Mutual coupling reduction of two PIFAs with a T-shape slot impedance transformer for MIMO mobile terminals," *IEEE Trans. Antennas Propag.*, Vol. 60, No. 3, 1521–1531, Mar. 2012.

16. Qi, H., X. Yin, L. Liu, Y. Rong, and H. Qian, "Mutual coupling suppression between two closely spaced microstrip antennas with an asymmetrical coplanar strip wall," *IEEE Antennas Wireless Propag. Lett.*, Vol. 15, 2016.
17. <http://www.antennatesting.com>.
18. <http://www.antennaworld.com>.