

Ultra-Wideband Bandpass Filter with Sharp Tuned Notched Band Rejection Based on CRLH Transmission-Line Unit Cell

Eman G. Ouf^{1, *}, Ashraf S. Mohra², Esmat A. Abdallah¹, and Hadia Elhennawy³

Abstract—The proposed filter satisfies the Federal Communications Commission ultra-wideband (FCC-UWB) specifications and also creates and controls sharp rejection notch-bands within the filter's passband in order to provide interference immunity from unwanted radio signals, such as wireless local area networks (WLAN) and worldwide interoperability for microwave access (WIMAX) that cohabit within the UWB spectrum. This filter is based on CRLH concept consisting of an asymmetric transmission line unit cell with a short circuited inductive stub to realize high performance in an operation band from 3.1 to 10.6 GHz with a very compact size of 16.4 mm × 5.0 mm. The main advantage of the proposed filter is that four notch frequencies are tuned in the UWB frequency band. The notch frequencies of the filter can be changed by increasing the length of the coupling stub which is controlled by using switching matrix equipment (Mini Circuit) instead of PIN diodes. To validate the design theory, a microstrip UWB BPF with four notch bands centered at frequencies 6.18, 5.9, 5.7, and 5.5 GHz is designed and fabricated.

1. INTRODUCTION

Ultra-wideband (UWB) systems have attracted increasing attention since the Federal Communications Commission released the unlicensed use of frequency spectrum 3.1–10.6 GHz for UWB applications in 2002 [1]. The UWB system has become one of the most promising technologies for short-range low-power indoor wireless communications. UWB BPF as one of the essential components of UWB systems has gained much attention in recent years.

Various techniques have been recently developed for UWB bandpass filters. Since 2005, various UWB bandpass filters have been designed and reported, including filters of composite lowpass and highpass structure [2], shorted-circuited stub filters [3, 4], and multiple-mode resonator (MMR) structure filters [5].

Since UWB communication devices occupy a large frequency spectrum (3.1–10.6 GHz), interference attenuation or avoidance with coexisting users is one of the key issues for UWB technology. A special effort has been directed towards research to introduce an electronically switchable or tunable narrow notched band within the passband of the UWB bandpass filter. There are many categories for the techniques of notch bands design as introduction of additional notch resonators [6], embedded open stubs [7], and asymmetric coupled fed lines [8].

To deal with different coexisting communication needs, the reconfigurable notch-band implementation is required, but little research is concentrated on a UWB BPF with reconfigurable, switchable, or tunable notch bands as in [9–13].

Reference [14] presents an example of UWB bandpass filter based on a composite right-left handed transmission line unit cell. The design involves an asymmetric unit cell with a short circuited inductive

Received 30 April 2017, Accepted 12 June 2017, Scheduled 26 June 2017

* Corresponding author: Eman Gamal Ouf (emanouf@eri.sci.eg).

¹ Electronics Research Institute, Dokki, Giza, Egypt. ² Benha Faculty of Eng., Benha University, Benha, Egypt. ³ Faculty of Eng., Ain Shams University, Cairo, Egypt.

stub to provide a filter with high passband selectivity and a cell composed of interdigital coupled lines with low pass band insertion loss across the UWB. This filter provides bandwidth expansion to cover the UWB (3.1–10.6 GHz).

In this paper, we introduce the filter in [14], but with tunable four notched bands at 6.18, 5.9, 5.7, and 5.5 GHz, with the notched-bandwidth in the passband of the filter to provide the interference immunity from the narrow band services such as WLANs and WiMAX coexisting with the UWB.

The paper is organized as follows. Section 2 introduces the design of the proposed filter in term of the shape of the filter, its dimensions and the simulation results. Section 3 provides the fabrication and the measurement of the proposed filter together with simulated results. Section 4 is the conclusion.

2. FILTER DESIGN

The proposed filter is designed based on the example described in [14] but with a new contribution which is controllable tunable four sharp rejection notched bands by adjusting the length of the coupling stub. Fig. 1 shows the microstrip UWB-BPF with tuned notched passband based on CRLH Transmission-line unit cell.

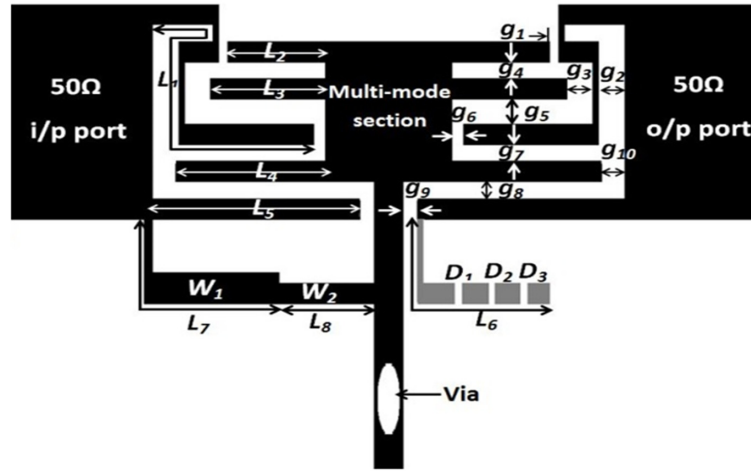

Figure 1. The proposed filter.

The optimized dimensions of the proposed filter are as shown in Table 1. All dimensions are in mm.

Table 1. Optimized dimensions of the proposed filter (all dimensions are in mm).

L_1	L_2	L_3	L_4	L_5	L_7	L_8	w_1	w_2	
9.3	3.4	4	5.2	7.2	5.3	3.3	0.3	0.2	
g_1	g_2	g_3	g_4	g_5	g_6	g_7	g_8	g_9	g_{10}
0.3	0.9	0.9	0.2	0.3	0.4	0.2	0.2	0.5	0.8

The dimension of the multi-mode section is $4.4 \text{ mm} \times 1.5 \text{ mm}$, and the length of the shunted line is 3.1 mm. Based on the above description the design procedure can be as follow:

- (i) The notched band depends on the transmission line ($L_5 + L_6$) in the output section.
- (ii) The notch frequency of the filter can be changed by adjusting the length of the coupling stub L_6 , as L_6 increases the center notch frequency decreases as shown in Table 2. The length L_6 is controlled

by using switching matrix equipment (mini circuit) where the character D will refer to the diode and the different diodes states will be described as follow:

- (a) When D_1, D_2, D_3 are off, the length L_6 will be equal to 2 mm, so the center notch frequency will be 6.18 GHz;
- (b) When D_1 is on and D_2, D_3 are off, the length L_6 will be equal to 3.1 mm, so, the center notch frequency will be 5.9 GHz;
- (c) When D_1, D_2 are on and D_3 is off, the length L_6 will be equal to 4.2 mm, so, the center notch frequency will be 5.7 GHz;
- (d) When D_1, D_2 and D_3 are on, the length L_6 will be equal to 5.3 mm, so, the center notch frequency will be 5.5 GHz.

So based on the above discussion, L_6 can be modified to control the notch frequency by modify its length.

Table 2. The (f_{notch}) against (L_6) variation.

L_6 (mm)	f_{notch} (GHz)
2	6.18
3.1	5.9
4.2	5.7
5.3	5.5

Figure 2 shows the S parameters of the proposed filter with different lengths of the coupling stub L_6 by using CST MWS, where the length of L_6 determines the notch frequency. These notches can filter out coexisting signals like WLAN and WIMAX.

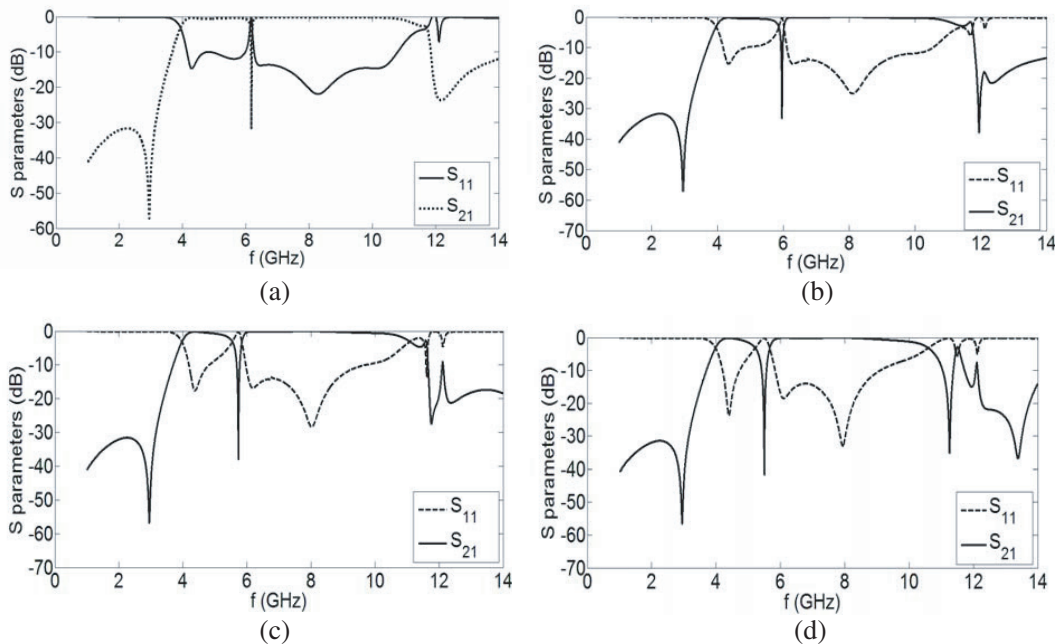
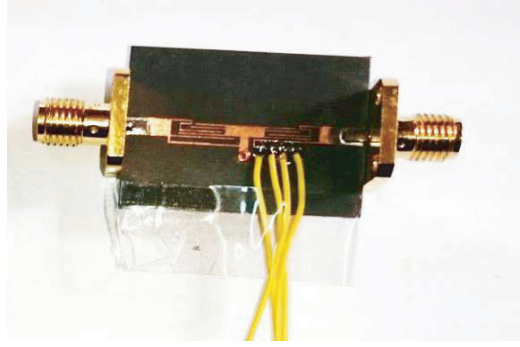
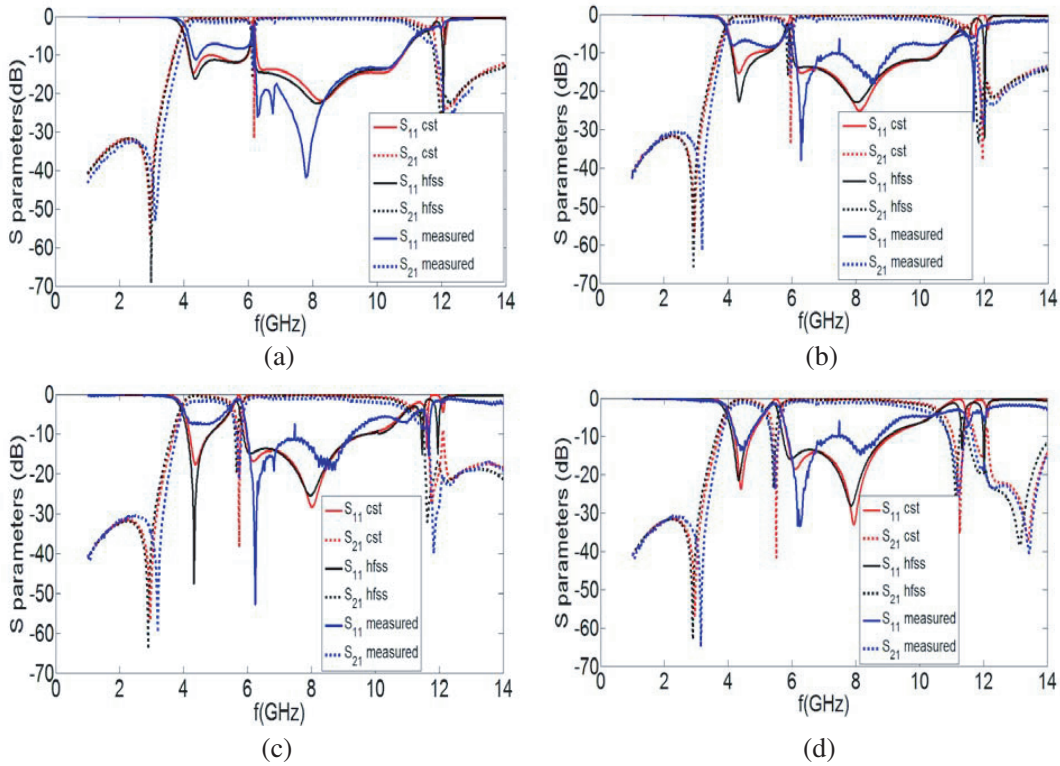

Figure 2. The simulated S_{11} and S_{21} using CST software package for different L_6 lengths. (a) $L_6 = 2.0$ mm, (b) $L_6 = 3.1$ mm, (c) $L_6 = 4.2$ mm, (d) $L_6 = 5.3$ mm.

Our filter design is compared with similar filters (the dielectric constant, filter size, notched frequency, and the band), and the comparison is given in Table 3.

Table 3. Comparison of the proposed filter with published UWB Bandpass filters.

No of Ref.	ϵ_r /height (mm)	Size	Notch frequency/ attenuation (dB)	Passband (GHz)
Ref. [15]	2.2/1.0	31 mm \times 20 mm	3.6/5.9/8.0/ > 10	3.1–10.6
Ref. [16]	2.65/1.0	30 mm \times 16 mm	5.3/7.8/ > 20	2.8–11
Ref. [17]	2.55/0.8	22.5 mm \times 13.7 mm	5.5/ > 10	3.1–10.6
Ref. [18]	3.38/0.508.	20 mm \times 15 mm	6/ > 20 (notch band from 5.8–6.2)	3.6–10.1
Our work	2.2/0.787	16.4 mm \times 5.0 mm	6.18/5.9/5.7/5.5/ > 10	3.1–10.6

**Figure 3.** A photo for the fabricated filter.**Figure 4.** The simulated and measured S_{11} and S_{21} for different L_6 lengths. (a) $L_6 = 2.0$ mm, (b) $L_6 = 3.1$ mm, (c) $L_6 = 4.2$ mm, (d) $L_6 = 5.3$ mm.

3. FABRICATION AND MEASUREMENTS

The proposed filter is simulated by two software packages CST version 2014 and 3D EM commercial software HFSS 13.0. The measured results are consistent with the simulated ones. The filter was designed and fabricated using a photolithographic technique on Rogers RT/Duroid 5880 with $\varepsilon_r = 2.2$, $h = 0.787$ mm, and $\tan \delta = 0.0009$. The photograph of the fabricated filter is shown in Fig. 3. Fig. 4 shows the measured and simulated results. The measured 3 dB passband is between 3.1 to 10.6 GHz with four notches at 6.18, 5.96, 5.73, and 5.5 GHz to filtering WLAN (5.425–5.875 GHz) and WiMAX (5.1–5.8 GHz). The filter has a compact size with dimensions 16.4 mm \times 5.0 mm.

Figure 4(a) shows the measured and simulated S_{11} and S_{21} with $L_6 = 2$ mm, $f_{\text{notch}} = 6.18$ GHz and can be tuned from 6.14 GHz to 6.21 GHz, which is a portion of the C-band radar system. Fig. 4(b) shows the measured and simulated S_{11} and S_{21} with $L_6 = 3.1$ mm, $f_{\text{notch}} = 5.9$ GHz and can be tuned from 5.85 GHz to 6.02 GHz to filter out WLAN (IEEE 802.11p-2010) which is intended for use in vehicular communication systems with band of 5.9 GHz (5.850–5.925 GHz) and may cause unwanted interference with UWB. Fig. 4(c) shows the measured and simulated S_{11} and S_{21} with $L_6 = 4.2$ mm, $f_{\text{notch}} = 5.7$ GHz and can be tuned from 5.54 GHz to 5.84 GHz to filter out WLAN (IEEE 802.11a), WIMAX (in Europe IEEE802.16), United States FCC- U- NIII- 2C (5.690–5.710 GHz), and FCC- U- NIII- 3 (5.690–5.730 GHz), also the FCC further clarified the use of channels in the 5.470–5.725 GHz band to avoid interference with weather radar systems (TDWR). Fig. 4(d) shows the measured and simulated S_{11} and S_{21} with $L_6 = 5.3$ mm $f_{\text{notch}} = 5.5$ GHz can be tuned from 5.23 GHz to 5.66 GHz to reject WLAN, United States FCC- U- NIII- 2C (5.490–5.510 GHz), and WIMAX.

4. CONCLUSION

A compact UWB BPF with reconfigurable notch bands based on CRLH transmission line unit cell is designed, simulated, and fabricated. Two packages of software are used, namely CST MWS and 3D EM commercial software HFSS 13.0. The simulated and measured results are comparable. The measured results are characterized using a N9928A FieldFox Handheld Microwave Vector Network Analyzer, 26.5 GHz. Small size and four notched frequencies add some advantages to this filter. The notched-bandwidth in the passband of the filter provides interference immunity from the narrow band services such as WLANs cohabit within the UWB. By adjusting the length of the coupling stub, the center notch frequency (f_{notch}) can be easily adjusted. The final size of the filter is 16.4 mm \times 5.0 mm, which is suitable for modern ultra-wideband wireless communication systems.

REFERENCES

1. Federal Communications Commission (FCC), Revision of Part 15 of the Commissions Rules Regarding: "Ultra-Wideband Transmission Systems," First Report and order, FCC 2-48, April 22, 2002.
2. Hsu, C. L., F. C. Hsu, and J. T. Kuo, "Microstrip bandpass filters for Ultra-Wideband (UWB) wireless communications," *IEEE MTT-S International Microwave Symposium Digest*, 679–682, 2005.
3. Hong, J. S. and H. Shaman, "An optimum ultra-wide-band microstrip filter," *Microwave and Optical Technology Letters*, Vol. 47, 230–233, 2005.
4. Li, X. and X. Ji, "Novel compact UWB bandpass filters design with cross-coupling between short-circuited stubs," *IEEE Microwave and Wireless Components Letters*, Vol. 24, 23–25, 2014.
5. Zhu, L., S. Sun, and W. Menzel, "Ultra-wideband (UWB) bandpass filters using multiple-mode resonator," *IEEE Microwave and Wireless Components Letters*, Vol. 15, 796–798, 2005.
6. Xu, J., W. Wu, W. Kang, and C. Miao, "Compact UWB bandpass filter with a notched band using radial stub loaded resonator," *IEEE Microwave and Wireless Components Letters*, Vol. 22, No. 7, 351–353, July 2012.

7. Shaman, H. and J. S. Hong, "Ultra-wideband (UWB) bandpass filter with embedded band notch structure," *IEEE Microwave and Wireless Components Letters*, Vol. 17, No. 3, 193–195, March 2007.
8. Kim, C. H. and K. Chang, "Ultra wideband (UWB) ring resonator bandpass filter with a notched band," *IEEE Microwave and Wireless Components Letters*, Vol. 21, No. 4, 206–208, April 2011.
9. García, R. G. and A. C. Guyette, "Reconfigurable multi-band microwave filters," *IEEE Transactions on Microwave Theory and Techniques*, Vol. 63, No. 4, 1294–1307, April 2015.
10. Wang, H., K. W. Tam, S. K. Ho, W. Kang, and W. Wu, "Design of ultra-wideband bandpass filters with fixed and reconfigurable notch bands using terminated cross-shaped resonators," *IEEE Transactions on Microwave Theory and Techniques*, Vol. 62, No. 2, 252–265, February 2014.
11. Horestani, A. K., Z. Shaterian, J. Naqui, F. Martín, and C. Fumeaux, "Reconfigurable and tunable S-shaped split-ring resonators and application in band-notched UWB antennas," *IEEE Transactions on Antennas and Propagation*, Vol. 64, No. 9, 3766–3776, September 2016.
12. Liang, J. G., X. Zhang, and L. Sun, "Compact UWB bandpass filter with triple notched bands using quadruple-mode resonator," *IEEE International Conference on Microwave and Millimeter Wave Technology (ICMMT)*, Vol. 1, 354–356, Beijing, China, June 2016.
13. Zheng, X., W. Liu, X. Zhang, and T. Jiang, "Design of dual band-notch UWB bandpass filter based on T-shaped resonator," *Progress In Electromagnetic Research Symposium*, 4482–4486, Shanghai, China, August 8–11, 2016.
14. Ahmed, K. U. and B. Virdee, "Ultra-wide band bandpass filter based on composite right/left handed transmission-line unit cell," *IEEE Transactions on Microwave Theory and Techniques*, Vol. 61, No. 2, 782–788, February 2013.
15. Wei, F., Z. D. Wang, F. Yang, and X. W. Shi, "Compact UWB BPF with triple-notched bands based on stub loaded resonator," *IEEE Electronics Letters*, Vol. 49, No. 2, 124–126, January 2013.
16. Song, Y., G. M. Yang, and G. Wen, "Compact UWB bandpass filter with dual notched bands using defected ground structures," *IEEE Microwave and Wireless Components Letters*, Vol. 24, No. 4, 230–232, April 2014.
17. Zhu, H. and Q. X. Chu, "Ultra-wideband bandpass filter with a notch-band using stub-loaded ring resonator," *IEEE Microwave and Wireless Components Letters*, Vol. 23, No. 7, 341–343, July 2013.
18. Shan, Q., C. Chen, and W. Wu, "Design of an UWB bandpass filter with a notched band using asymmetric loading stubs," *IEEE International Conference on Microwave and Millimeter Wave Technology (ICMMT)*, Vol. 2, 5–8, June 2016.