

Receiver Coil Position Selection through Magnetic Field Coupling of a WPT System Used for Powering Multiple Electronic Devices

Siddharth Sahany, Sushree S. Biswal, Durga P. Kar,
Asru Abhijit Pattnaik, and Satyanarayan Bhuyan*

Abstract—A wireless power transfer system based on magnetic resonant coupling (MRC) is preferred in many applications as it provides good balance between power transfer efficiency and physical separation distance. However, wireless power transfer to multiple loads through magnetic resonance coupling demands time due to the noteworthy advancement in consumer portable electronic devices. However, operating multiple loads corresponding to their optimum power level is a major concern which mostly depends on the position of the receiving coils with respect to the transmitting coil. This article presents an experimental investigation to find the best suited position of the multiple receiving coils corresponding to a spirally configured transmitting coil for powering multiple loads at their optimal power level. Through this technique multiple electronic devices can be powered up not only in one direction but also in both directions with their optimal power level. The findings will greatly assist the design of a resonant wireless power transfer system for powering multiple loads.

1. INTRODUCTION

In recent years, magnetic resonance coupling (MRC) based wireless power transfer (WPT) technology is getting considerable attention worldwide as an alternative of plug in power transfer [1–4]. Based on the well-known principle of magnetic resonance coupling, resonant inductively coupled WPT system has been proven the most efficient non-radiative type over short to medium power transfer distance [5–8]. With the ability to transfer power between separate pieces of equipment without conduit, it greatly reduces the risk of electric shock as well as electric sparking which indirectly extends the life span of electrical equipment. In particular, most of the research studies reported so far focus on WPT with direct link where a single transmitting and a receiving resonator are directly coupled [9–11] or WPT with indirect link, i.e., transmitter and receiver resonators with interposed additional resonators [12, 13]. However, the configuration of interest is the one in which multiple receiving resonators are resonantly coupled with a single transmitting resonator which has been adopted to provide power to multiple devices for practical applications. From the prospective of recent advancement in small and portable electronic devices, wireless power transfer to multiple loads can be thought of as an imperative issue in the application set of resonant wireless power transfer technology. The feasibility of the wireless power transfer to multiple receivers has been widely studied and proven to be robust and comparatively better in terms of power delivery ability and efficiency [14–22]. However, multiple receiving coils used for powering low power portable electronic devices are usually small in dimension. So placement of these receiving coils corresponding to the transmitting coil is becoming key design consideration for powering multiple loads simultaneously with their optimal level. Again, position of the receiving coils so as to maintain maximum power transfer to multiple loads is not generalized one, rather transmitting coil

Received 19 July 2019, Accepted 24 September 2019, Scheduled 2 October 2019

* Corresponding author: Satyanarayan Bhuyan (satyanarayanbhuyan@soa.ac.in).

The authors are with the Department of Electronics and Communication Engineering, Institute of Technical Education and Research, Siksha ‘O’ Anusandhan, Deemed to be University, Bhubaneswar 751030, India.

configuration specific. So these key points have to be addressed before designing a magnetic resonance coupling based wireless power transfer system for powering multiple loads. Keeping view of these, this article presents an experimental investigation in order to find the best suited position of the multiple receiving coils corresponding to a spirally configured transmitting coil for powering multiple loads with their optimal power level. Through this technique multiple electronic devices can be powered up not only in one direction but also in both directions with their optimal power level.

2. EXPERIMENTAL SETUP AND OPERATING MECHANISM

The process involved in selection of receiver position for powering single and multiple (two-loads) electronic devices through RIC-WPT system is shown as the block diagram in Figs. 1(a)–(b). An experimental setup has been designed in order to carry out the experimental investigations, and its photograph is depicted in Fig. 2. Here in this system, a single vertically placed spirally configured

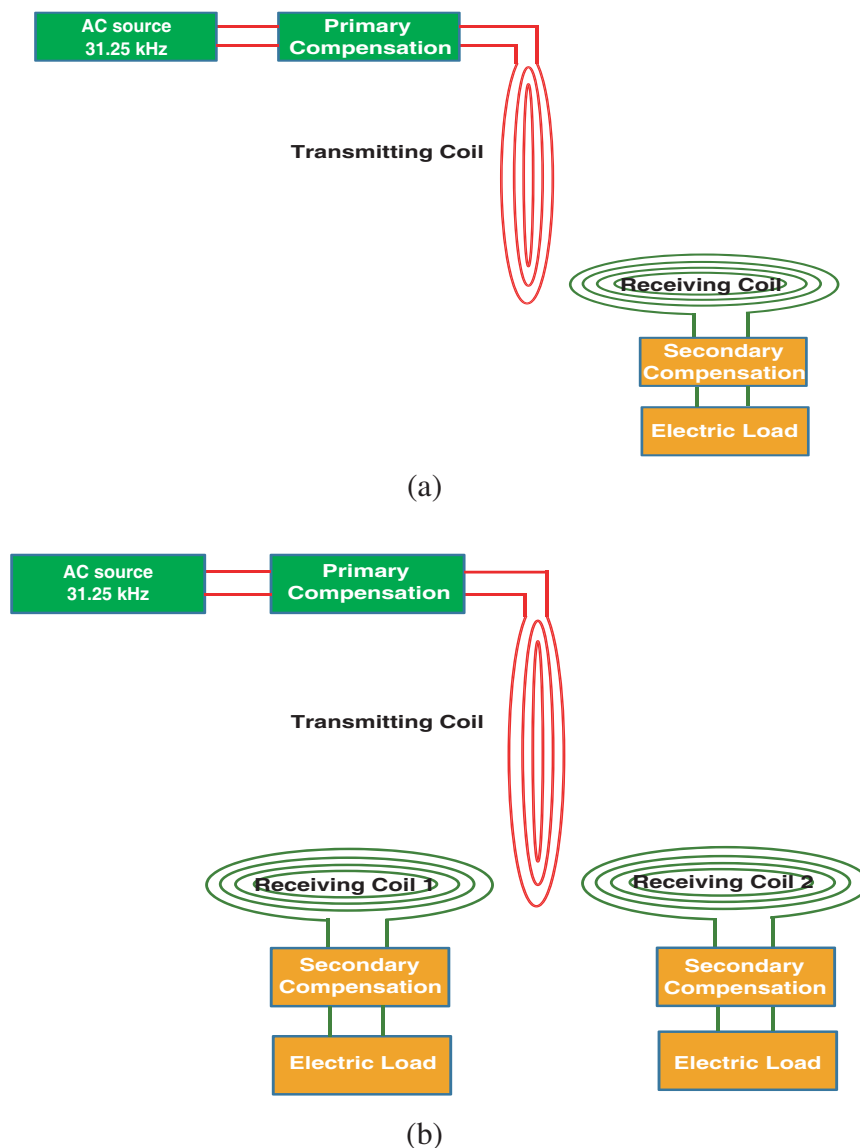

Figure 1. (a), (b) Experimental setup block diagram of RIC-WPT system for single load and multiple loads respectively.

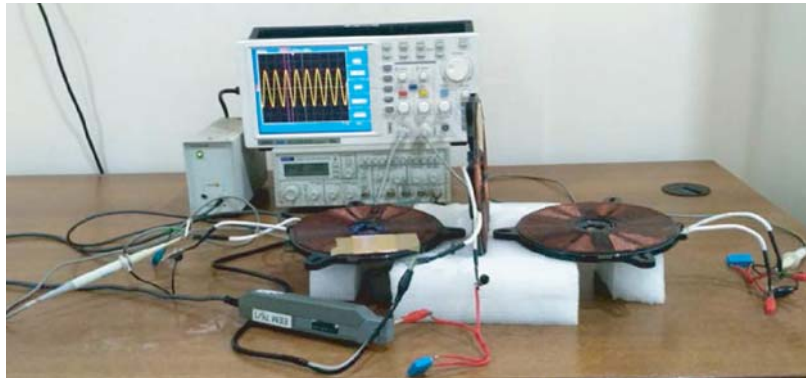

Figure 2. Experimental setup of RIC-WPT system for multiple loads.

transmitting coil is resonantly coupled with two nearby laterally aligned spiral receiving coils of same radius. A high frequency voltage source is used as input power source and connected in series with the transmitting coil.

The transmitting coil gets excited through a Radio Frequency voltage source. The high frequency voltage source facilitates high frequency current of maximum amplitude by providing series resonance in the transmitter coil through an addition of external capacitor. Both the receiver coils are externally compensated through capacitors connected in series and resonated at the same operating frequency of the transmitter coil. Both the receiver coils are deliberately kept in horizontal aligned position with the intention of intercepting minimum flux generated by the transmitting coil, hence minimum power will be transferred to both the receiving coils. The positions of the receiving coils are varied along the vertically aligned transmitting coil in order to find the best suited location for maximum power transfer. With this most awful possible combination, at a particular region of the transmitting coil if the power transfer to the receiving coil is maximum then it is obvious that for other alignment combinations, the particular region of the transmitting coil is the best suited location for the receiving coils to be placed.

3. EQUIVALENT CIRCUIT MODEL OF WIRELESS POWER TRANSFER TO SINGLE AND MULTIPLE LOADS

With magneto-quasistatic behaviour of the resonant inductive link, the magnetic field energy in the transmitting coil instead of radiating to the space is stored in the near field. Hence, any radiation losses can be assumed negligible and assuming the coil as electrically small, thus the current flow through the coil is considered uniformly distributed. The simplified electrical equivalent circuit models of the wireless power transfer system for single and multiple loads have been depicted in Figs. 3(a)–(b). The electrical parameters associated with the transmitting coil and receiving coils (R , L and C) are denoted with subscripts T and R , respectively. The equivalent series resistance of the coil is R ; inductance of the coil is L , and one external capacitor C is used to provide resonance. M_{12} is the mutual inductance of the transmitting and receiving coils, and ω represents the operating frequency. An input A.C. source with RMS voltage V_P with equivalent internal source resistance R_S is connected to the transmitting coil. The mutual coupling between the receiving coils is not included in the circuit analysis as it has a small impact on the efficiency distribution [19]. Again, in order to avoid complexity in the system analysis, the mutual coupling between the receiving coils is ignored.

Similar coils have been taken for designing transmitting and receiving coils, so their equivalent associated circuit parameters are equal and operated at the same resonant frequency. The resonant frequency is given by

$$f_r = \frac{1}{2\pi\sqrt{L_T C_T}} = \frac{1}{2\pi\sqrt{L_R C_R}} \quad (1)$$

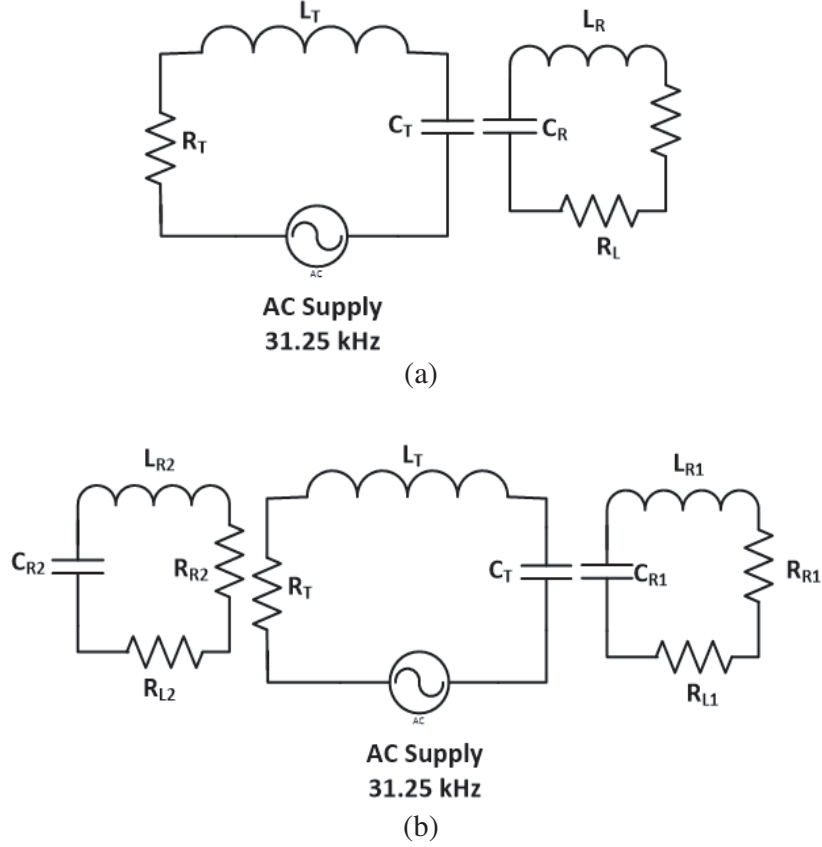

Figure 3. (a), (b) Equivalent circuit models of RIC-WPT system for single and multiple loads.

For single load wireless power transfer system, the transmitting and receiving coil impedances are

$$\begin{cases} Z_T = R_T + j \left(\omega L_T - \frac{1}{\omega C_T} \right) \\ Z_R = R_R + R_L + j \left(\omega L_R - \frac{1}{\omega C_R} \right) \end{cases} \quad (2)$$

The reflected impedance from the receiving coil to the transmitting coil given by [19] is as follows:

$$Z_r = \frac{(\omega M_{12})^2}{Z_R} = \frac{(\omega M_{12})^2 \left(R_R + R_L - j\omega L_R + \frac{j}{\omega C_R} \right)}{(R_R + R_L)^2 + \left(\omega L_R - \frac{1}{\omega C_R} \right)^2} \quad (3)$$

At resonance the current in the transmitting coil is calculated as

$$I_T = \frac{V_P}{Z_T + Z_r} = \frac{V_P}{R_T + \frac{(\omega M_{12})^2}{R_R + R_L}} \quad (4)$$

The available power in the transmitting coil drawn from the source is

$$P_{\text{input}} = \frac{(V_P)^2}{R_T + \frac{(\omega M_{12})^2}{R_R + R_L}} \quad (5)$$

The power received at the receiving coil is

$$P_R = I_T^2 Z_r = I_T^2 \frac{(\omega M_{12})^2}{R_R + R_L} = \left[\frac{V_P}{R_T + \frac{(\omega M_{12})^2}{R_R + R_L}} \right]^2 \frac{(\omega M_{12})^2}{R_R + R_L} \quad (6)$$

The portion of the power received at the receiving coil delivered to the load is as follows

$$P_L = \frac{P_R}{R_R + R_L} R_L = \left[\frac{V_P}{R_T + \frac{(\omega M_{12})^2}{R_R + R_L}} \right]^2 \frac{(\omega M_{12})^2}{(R_R + R_L)^2} R_L \quad (7)$$

In the case of wireless power transfer to multiple loads, the resonant frequencies of the transmitting coil and receiving coils are same and are given as follows

$$f_r = \frac{1}{2\pi\sqrt{L_T C_T}} = \frac{1}{2\pi\sqrt{L_{R1} C_{R1}}} = \frac{1}{2\pi\sqrt{L_{R2} C_{R2}}} \quad (8)$$

Followed by Equation (3), the reflected load impedances from both the receiving coils seen at the input of the transmitting coil are

$$Z_{ref1} = \frac{(\omega M_{12})^2}{Z_{R1}} = \frac{(\omega M_{12})^2 \left(R_{R1} + R_{L1} - j\omega L_{R1} + \frac{j}{\omega C_{R1}} \right)}{(R_{R1} + R_{L1})^2 + \left(\omega L_{R1} - \frac{1}{\omega C_{R1}} \right)^2} \quad (9)$$

$$Z_{ref2} = \frac{(\omega M_{12})^2}{Z_{R2}} = \frac{(\omega M_{12})^2 \left(R_{R2} + R_{L2} - j\omega L_{R2} + \frac{j}{\omega C_{R2}} \right)}{(R_{R2} + R_{L2})^2 + \left(\omega L_{R2} - \frac{1}{\omega C_{R2}} \right)^2} \quad (10)$$

The input driving current through the transmitting coil at resonance is

$$I_T = \frac{V_P}{Z_T + Z_{ref1} + Z_{ref2}} = \frac{V_P}{R_T + \frac{(\omega M_{12})^2}{R_{R1} + R_{L1}} + \frac{(\omega M_{12})^2}{R_{R2} + R_{L2}}} \quad (11)$$

Hence, the source available power in the case of multiple loads can be calculated as

$$P_{input} = I_T^2 (Z_T + R_{ref1} + R_{ref2}) = \frac{V_P^2}{R_T + \frac{(\omega M_{12})^2}{R_{R1} + R_{L1}} + \frac{(\omega M_{12})^2}{R_{R2} + R_{L2}}} \quad (12)$$

By following the same procedure as in Equations (6) and (7) for single coil, the power delivered to the both loads (P_{L1} & P_{L2}) will be

$$P_{L1} = \frac{P_R}{R_{R1} + R_{L1}} R_{L1} = \left[\frac{V_P}{R_T + \frac{(\omega M_{12})^2}{R_{R1} + R_{L1}} + \frac{(\omega M_{12})^2}{R_{R2} + R_{L2}}} \right]^2 \frac{(\omega M_{12})^2}{(R_{R1} + R_{L1})^2} R_{L1} \quad (13)$$

$$P_{L2} = \frac{P_R}{R_{R2} + R_{L2}} R_{L2} = \left[\frac{V_P}{R_T + \frac{(\omega M_{12})^2}{R_{R1} + R_{L1}} + \frac{(\omega M_{12})^2}{R_{R2} + R_{L2}}} \right]^2 \frac{(\omega M_{12})^2}{(R_{R2} + R_{L2})^2} R_{L2} \quad (14)$$

From Equations (13) and (14), it is found that multiple receiving coils of equal dimension terminated with similar loads will receive equal amount of power irrespective of the direction. However, the coil size and the separation gap between the coils should be taken into consideration not only for the designed parameters but also as a performance estimate.

4. RESULTS AND DISCUSSION

In order to determine the best suited position of the receiving coil corresponding to the transmitting coil for maximizing the power transfer to load, profile of mutual coupling, voltage across the load, and load power due to the transmitter coil have been illustrated. The optimal position of receiving coils with respect to the transmitting coil has been experimentally determined for single as well as for two loads. Configuration wise, the spirally configured transmitting and receiving coils in both single and two loads

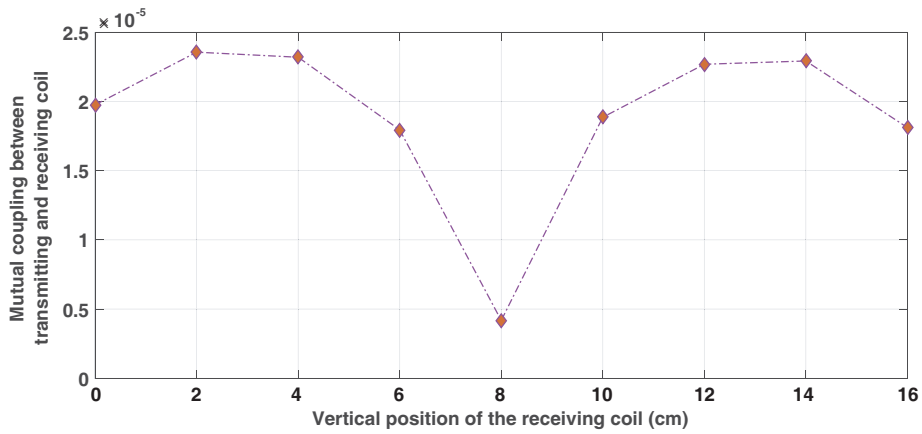

(a)

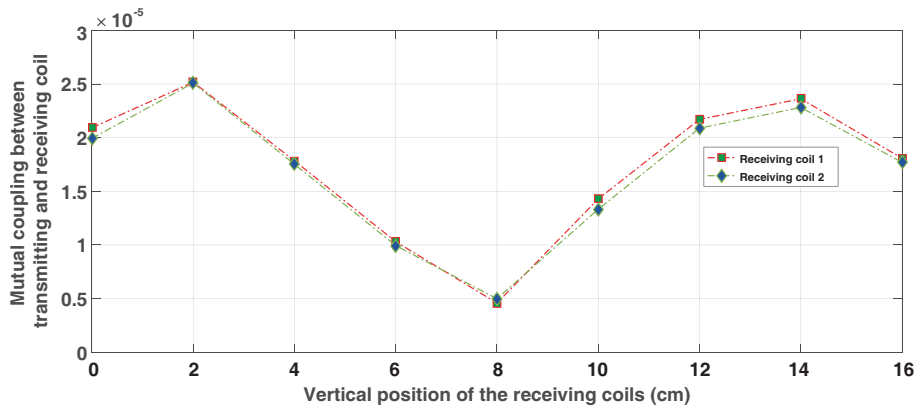

(b)

Figure 4. (a), (b) Variation of mutual coupling with respect to vertical position of the receiving coil for single load and two-loads.

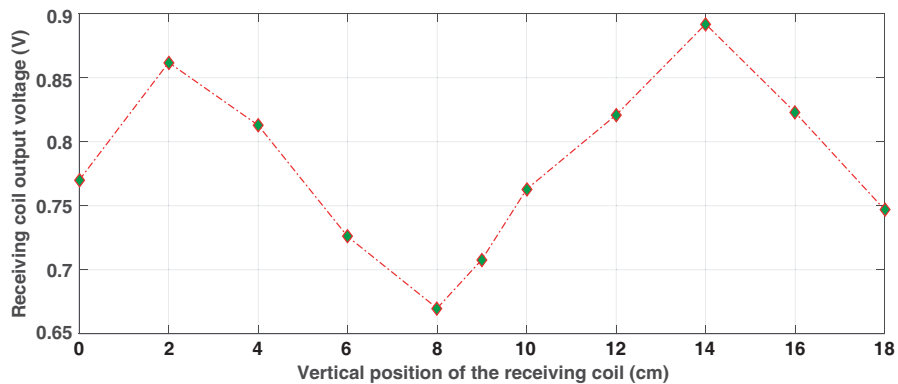

(a)

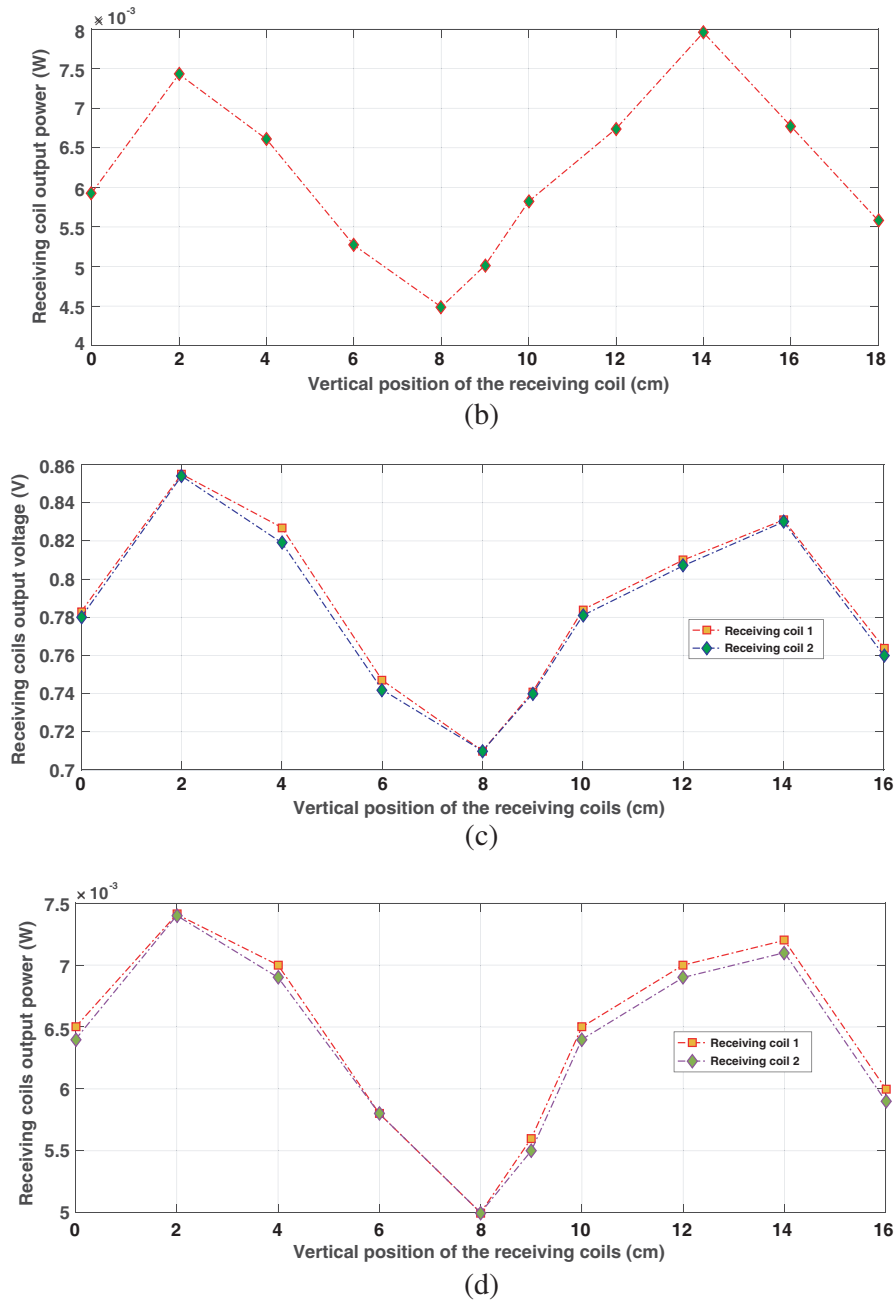

Figure 5. (a)–(d) Variation of the load voltage and the power transfer to the load in single as well as in two-loads corresponding to the position of the receiving coil.

have been taken with equal dimension, i.e., 16 cm diameter each, and operating resonant frequencies in both cases have been fixed at 31.25 kHz.

The mutual coupling characteristics with position variation of horizontally aligned receiving coil along vertical plane of the transmitting coil in both single and two loads are illustrated in Figs. 4(a)–(b). It is seen that in both the cases, mutual coupling is the least at the centre and at the extreme edge of the transmitting coil but attains its maximum value in the peripheral region. This implies, for a specific transmitting coil dimension, that an optimal coupling region exists where the mutual coupling is maximum.

Similarly, variation of the load voltage and the power transfer to the load in single as well as two loads corresponding to the position of the receiving coil have been found experimentally and depicted in

Figs. 5(a)–(d). It is clearly found in both the cases that the voltage across the load and power transfer to the load varies with the same fashion as variation of the mutual coupling, which emphasizes the fact that there exists a particular peripheral region on the transmitting coil where the load voltage and power transfer to the load will be maximum. It is also observed that in the other part, the voltage across the load and power delivered to the load are comparably low. The above result ascertains an interesting fact that no matter whether it has single or multiple loads, placed one sided or both sided much closer to the transmitting coil, maximum power will be transferred to the load if the receiving coil is placed on the specific region, and that region is known as the optimal region. The optimal region is specific and fixed for a particular coil configuration and very much dependant on the dimension of the transmitting coil. At the optimal region, the coupling is stronger than the other part which implies that the induced voltage in the receiving coil is maximum and so as the power transfer to the load.

5. CONCLUSIONS

The magnetic resonance based wireless power transfer system for single and multiple loads have been experimentally investigated through equivalent circuit model analysis. In both cases, the variation of mutual coupling, load voltage, and power delivery ability to the load corresponding to different positions of the receiving coil along the vertical plane of the transmitting coil have been presented. The finding articulates the critical region on the transmitting coil at which the receiver coil (single or multiple loads) has to be placed for which maximum power transfer can be achieved in resonant inductively coupled wireless power transfer system. The experimental results assert that no matter whether it has single or multiple loads, placed one sided or both sided much closer to the transmitting coil, maximum power will be transferred to the load if the receiving coil is placed on the optimal region. The obtained results with appropriate elucidation will provide future guidelines for designing a resonance based wireless power transfer system with maximum power delivery capability to multiple loads.

REFERENCES

1. Pedder, D. A. G., A. D. Brown, and J. A. Skinner, "A contactless electrical energy transmission system," *IEEE Transactions on Industrial Electronics*, Vol. 46, 23–30, 1999.
2. Kim, C.-G., D.-H. Seo, J.-S. You, J.-H. Park, and B. H. Cho, "Design of a contactless battery charger for cellular phone," *IEEE Transactions on Industrial Electronics*, Vol. 48, 1238–1247, 2001.
3. Covic, G. A. and J. T. Boys, "Modern trends in inductive power transfer for transport applications," *IEEE Journal of Emerging and Selected Topics in Power Electronics*, Vol. 1, No. 1, 28–41, 2013.
4. Shinohara, N., "The wireless power transmission: Inductive coupling, radio wave, and resonance coupling," *Wiley Interdisciplinary Reviews: Energy and Environment*, Vol. 1, 337–346, 2012.
5. Kurs, A., A. Karalis, R. Moffatt, J. D. Joannopoulos, P. Fisher, and M. Soljacic, "Wireless power transfer via strongly coupled magnetic resonances," *Science*, Vol. 317, 83–86, 2007.
6. Ho, S. L., J. Wang, W. Fu, and M. Sun, "A comparative study between novel witrlicity and traditional inductive magnetic coupling in wireless charging," *IEEE Transaction on Magnetics*, Vol. 47, 1522–1525, 2011.
7. Kar, D. P., P. P. Nayak, and S. Bhuyan, "Automatic frequency tuning wireless charging system for enhancement of efficiency," *Electronics Letters*, Vol. 50, No. 24, 1868–1870, 2014.
8. Kar, D. P., S. S. Biswal, P. K. Sahoo, P. P. Nayak, and S. Bhuyan, "Selection of maximum power transfer region for resonant inductively coupled wireless charging system," *AEU — International Journal of Electronics and Communications*, Vol. 84, 84–92, 2018.
9. Hui, S. Y. R. and W. W. C. Ho, "A new generation of universal contactless battery charging platform for portable consumer electronic equipment," *IEEE Transactions on Power Electronics*, Vol. 20, 620–627, 2005.
10. Parise, M., V. Tamburrelli, and G. Antonini, "Mutual impedance of thin-wire circular loops in near-surface applications," *IEEE Transactions on Electromagnetic Compatibility*, Vol. 61, 558–563, 2019.

11. Orekan, T., P. Zhang, and C. Shih, "Analysis, design, and maximum power-efficiency tracking for undersea wireless power transfer," *IEEE Journal of Emerging and Selected Topics in Power Electronics*, Vol. 6, No. 2, 843–854, 2018.
12. RamRakhiani, A. K., S. Mirabbasi, and M. Chiao, "Design and optimization of resonance-based efficient wireless power delivery systems for biomedical implants," *IEEE Transactions on Bio. Circuits and Systems*, Vol. 5, 48–63, 2011.
13. Bhuyan, S., S. K. Panda, K. Sivananda, and R. Kumar, "A compact resonance-based wireless energy transfer system for implanted electronic devices," *International Conference on Energy, Automation and Signal*, 1–3, 2011.
14. Kar, D. P., P. P. Nayak, and S. Bhuyan, "Bi-directional magnetic resonance based wireless power transfer for electronic devices," *Applied Physics Letters*, Vol. 107, No. 13, 3901, 2015.
15. Cannon, B. L., J. F. Hoburg, D. D. Stancil, and S. C. Goldstein, "Magnetic resonant coupling as a potential means for wireless power transfer to multiple small receivers," *IEEE Transactions on Power Electronics*, Vol. 24, No. 7, 1819–1825, 2009.
16. Sahany, S., S. S. Biswal, D. P. Kar, P. K. Sahoo, and S. Bhuyan, "Impact of functioning parameters on the wireless power transfer system used for electric vehicle charging," *Progress In Electromagnetics Research M*, Vol. 79, 187–197, 2019.
17. Low, Z. N., J. J. Casanova, and J. Lin, "A loosely coupled planar wireless power transfer system supporting multiple receivers," *Advances in Power Electronics*, Vol. 2010, Article ID 546529, 13 pages, 2010.
18. Ahn, D. and S. Hong, "Effect of coupling between multiple transmitters or multiple receivers on wireless power transfer," *IEEE Transactions on Industrial Electronics*, Vol. 60, No. 7, 2602–2613, 2013.
19. Zhang, Y., T. Lu, Z. Zhao, F. He, K. Chen, and L. Yuan, "Selective wireless power transfer to multiple loads using receivers of different resonant frequencies," *IEEE Transactions on Power Electronics*, Vol. 30, No. 11, 6001–6005, 2015.
20. Fu, M., T. Zhang, C. Ma, and X. Zhu, "Efficiency and optimal loads analysis for multiple-receiver wireless power transfer systems," *IEEE Transactions on Microwave Theory and Techniques*, Vol. 63, No. 3, 801–812, 2015.
21. Kar, D. P., P. P. Nayak, S. Bhuyan, and S. K. Panda, "Study of resonance based wireless electric vehicle charging system in close proximity to metallic objects," *Progress In Electromagnetic Research M*, Vol. 37, 183–189, 2014.
22. Choi, J. and C. H. Seo, "Analysis on transmission efficiency of wireless energy transmission resonator based on magnetic resonance," *Progress In Electromagnetics Research M*, Vol. 19, 221–237, 2011.