

A Novel Broadband Double Whip Antenna for Very High Frequency

Hengfeng Wang*, Chao Liu, Huaning Wu, and Xu Xie

Abstract—In this paper, a new type of single loaded broadband double-whip antenna is designed for very high frequency (VHF). The simulation model by moment method is established to analyze the influence of antenna spacing on the performance of a double-whip antenna. The location of antenna loading and the parameters of loading network and broadband matching network are optimized by grasshopper optimization algorithm, and the voltage standing wave ratio (VSWR), gain, pattern, and roundness of double-whip antenna are calculated. In fact, a fabricated prototype of the proposed antenna is realized. The measured VSWR is consistent with the simulation results, which is less than 3 at all frequencies, with an average value of 1.89; the maximum directional gain is greater than 2.01 dB, with a maximum of 6.44 dB and average value of 3.79 dB; the minimum roundness of antenna gain is 0.03 dB (at 3 MHz), and the maximum roundness is 1.87 dB (at 30 MHz); the efficiency is all over 51%, with a maximum value of 79% and an average value of 60.71%.

1. INTRODUCTION

Antenna is an important front-end device which cannot be separated from any radio communication system. In modern communication technology, especially in military communications, with the increasing frequency hopping rate and wider frequency hopping range, the original narrowband antenna can no longer satisfy the communication requirements nowadays. In addition, there are many antennas densely distributed in a narrow space, which cannot be realized on mobile carriers such as shipborne and vehicle-borne with very limited space. Moreover, the interference between antennas is more serious, which seriously affects the quality of communication. This requires the development of broadband antennas so that multiple stations can share a pair of antennas to reduce the number of antennas. Therefore, in order to achieve the confidentiality of communication and reduce signal interference, the demand for miniaturized, broadband, and omnidirectional antennas is more and more urgent.

Although the general single whip antenna can meet the requirements of broadband, its gain and efficiency in low frequency band are generally very small, which seriously affects the effect of remote communication [1–5]. In order to improve the radiation capability of the antenna, the double-whip antenna structure with combined bottom feed is usually adopted. This structure usually can use the mirror image principle of the carrier surface or the metal plate to be equivalent to the lower part of the symmetric oscillator structure [6]. Due to the wide bandwidth of VHF band and up to 10 octave frequencies, the traditional VHF double-whip antenna mostly uses two pairs of double-whip with high and low ports to cover the whole short-wave band [7], which is very difficult to achieve for the ship-borne and vehicle-borne platform with very tight space. Although the VSWR and gain of the 1.6 m double-whip antenna designed in [8] are good, the introduction of a transmission line for coarse matching and resistance in matched network will seriously affect the radiation efficiency of the antenna.

In this paper, the method of moments is used to analyze the double-whip antenna [9]. The electromagnetic simulation software FEKO based on the method of moments is used to calculate the

Received 17 October 2019, Accepted 14 January 2020, Scheduled 10 February 2020

* Corresponding author: Hengfeng Wang (henvin999@163.com).

The authors are with the College of Electronic Engineering, Naval University of Engineering, Wuhan 430033, China.

structure of the double-whip antenna. In the form of a single loading and broadband matching network, the antenna not only achieves good broadband characteristics, but also has high gain and efficiency. The design and implementation of load network and broadband matching network is one of the key technologies [10–13]. The single-load structure can not only reduce the loss of resistance to the antenna, ensure good antenna efficiency, but also reduce the complexity of the antenna and reduce the difficulty coefficient of structure realization. Broadband matching network is composed of low-power or lossless components, which can effectively match the impedance of antenna and feeder, and make antenna have good broadband characteristics. Because the antenna is a self-supporting structure with fewer loading points, the traditional antenna composed of two pairs of double-whip antennas with high and low ports is transformed into one pair of double-whip antennas, which greatly reduces the space occupied and makes the overall design of the antenna miniaturized and more adaptable.

2. ANALYSIS OF DOUBLE WHIP ANTENNA

2.1. Moment Method Analysis

The double-whip antenna is a simple but practical antenna array. The radiation pattern of the antenna array depends on the antenna type, orientation, element position in space, and the amplitude and phase of the exciting current. Using multi-monopole antenna model, widening the working bandwidth of antenna is also one of the main contents of antenna research. The double-whip antenna consists of two bottom-fed monopole antennas. As shown in Fig. 1, the height of the double-whip antenna is h , and the base height is h_0 . The distance between the two antennas is d .

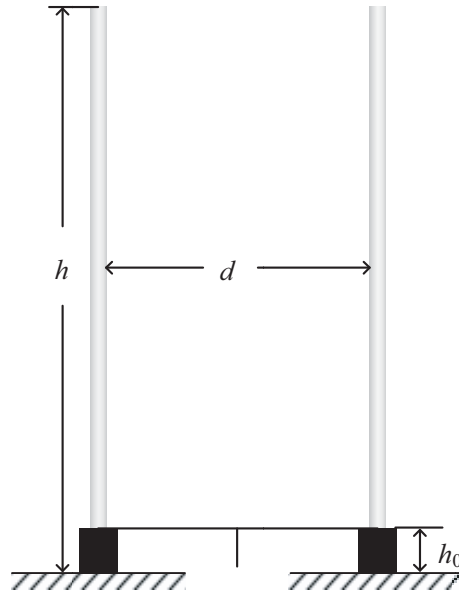

Figure 1. Diagram of a double-whip antenna.

Suppose that the external field is $E^i(r)$; the induced current J_s and charge σ are generated on the antenna surface S ; and then the radiation [3] is formed by J_s and σ . The radiation field can be expressed as:

$$\mathbf{E}^s(r) = \frac{-j\eta}{4\pi k} \int_v \mathbf{J}(r') \cdot \overline{\overline{\mathbf{G}}}(r, r') dV' \quad (1)$$

where $\overline{\overline{\mathbf{G}}}(r, r') = (k^2 \overline{\overline{\mathbf{I}}} + \nabla \nabla) g(r, r')$, $g(r, r') = \exp(-jk|r - r'|)/|r - r'|$.

The electric field integral equation (EFIE) can be expressed as follows:

$$\frac{-j\eta}{4\pi k} \left\{ k^2 \int_C I(l') l' \cdot l K K(l, l') dl' + \frac{d}{dl'} \int_C \frac{d}{dl'} I(l') K(l, l') dl' \right\} = -E^i(l) \cdot l, \quad l \in C \quad (2)$$

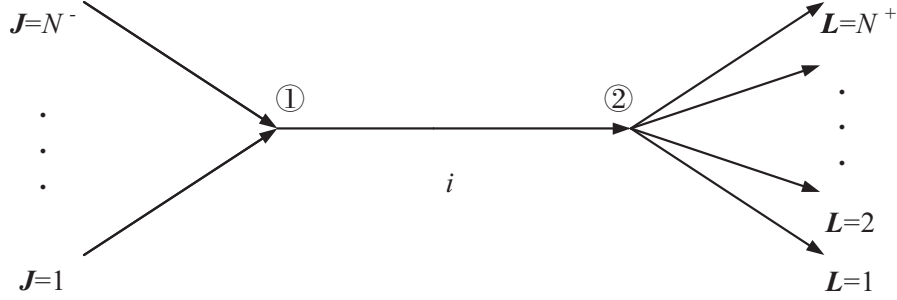

Figure 2. The wiring segment contained in the i -th basis function.

where $K(l, l') = \frac{1}{2\pi} \int_{-\pi}^{\pi} \frac{e^{-jkR}}{R} d\phi'$.

This paper uses the sinusoidal interpolation basis function (see Fig. 2). The electrical characteristics of the point-matched antenna are calculated.

The current on segment i can be expressed as:

$$f_i^0(s) = A_i^0 + B_i^0 \sin k_s(s - s_i) + C_i^0 \cos k_s(s - s_i), \quad |s - s_i| < \Delta_i/2 \quad (3)$$

The current of the conductor segment connected to the 1-end of the i -th segment is as follows:

$$f_j^0(s) = A_j^- + B_j^- \sin k_s(s - s_j) + C_j^- \cos k_s(s - s_j), \quad |s - s_j| < \Delta_j/2 \quad (4)$$

where $j = 1, \dots, N^-$.

The current of the conductor segment connected to the 2-end of the i -th segment is as follows:

$$f_l^+(s) = A_l^+ + B_l^+ \sin k_s(s - s_l) + C_l^+ \cos k_s(s - s_l), \quad |s - s_l| < \Delta_l/2 \quad (5)$$

where $l = 1, \dots, N^+$.

The current on the node satisfies Kirchhoff's law, so the total current expansion formula for the N segments structure is

$$I(s) = \sum_{i=0}^N \alpha_i f_i(s) \quad (6)$$

where the basis function of the center of the i -th segment is

$$f_i(s) = f_i^0(s) + \sum_{j=1}^{N^-} f_j^-(s) + \sum_{l=1}^{N^+} f_l^+(s) \quad (7)$$

The current is expanded and replaced by an integral equation of electric field or magnetic field, and a dot matrix matching method is used to test it, then a matrix equation [14] is obtained. The current expansion coefficient of the antenna can be obtained by solving the matrix equation, and the parameters of current, surrounding field, antenna input impedance, VSWR, far-field pattern and gain can be obtained.

2.2. Directional Analysis

The double-whip antenna is usually fed by a parallel bottom feed. The feed currents are equal in amplitude and phase. The maximum direction of the radiation pattern of the antenna always points to the side of the antenna axis, which belongs to the side-emitting array. In order to make the radiation direction of the double-whip antenna more omnidirectional and reduce the non-circularity of the antenna pattern, it is necessary to calculate and study the directivity of the double-whip antenna.

According to the directional product theorem, the directional function is equal to the product of the directional function and the array factor of the unit antenna. Let the height of the double-whip antenna be h , the spacing be d , and the current relationship between the two pairs of single-whip antennas is $I_2 = mI_1 e^{j\xi}$, where m and ξ are both real. It is shown that the current amplitude on antenna 2 is m

times of that of antenna 1, and phase is ξ ahead of antenna 1. The directional function of a single whip antenna can be expressed as

$$f_1(\theta, \phi) = \left| \frac{\cos(kh \cos \theta) - \cos(kh)}{\sin \theta} \right| \quad (8)$$

Array factor is

$$f_a(\theta, \phi) = |1 + me^{j\Psi}| \quad (9)$$

where $\Psi = \xi + k\Delta r = \xi + kd \cos \delta$; $k = 2\pi/\lambda$ is the wave number; δ is the angle between the wave ray and the axis of the double-whip antenna; $\cos \delta = \sin \theta \sin \phi$.

Therefore, the synthetic directional function $f(\theta, \phi)$ of the double-whip antenna can be written as

$$f(\theta, \phi) = f_1(\theta, \phi) \times f_a(\theta, \phi) = \left| \frac{\cos(kh \cos \theta) - \cos(kh)}{\sin \theta} \right| \times |1 + me^{j(\xi + kd \sin \theta \sin \phi)}| \quad (10)$$

For a double-whip antenna with the same amplitude and phase feed, $m = 1, \xi = 0$, formula (10) can be simplified to

$$f(\theta, \phi) = \left| \frac{\cos\left(\frac{2\pi}{\lambda}h \cos \theta\right) - \cos\left(\frac{2\pi}{\lambda}h\right)}{\sin \theta} \right| \times |1 + e^{j\left(\frac{2\pi}{\lambda}d \sin \theta \sin \phi\right)}| \quad (11)$$

Let $\theta = 90^\circ$, and the directional function of the double-whip antenna in the horizontal direction can be expressed as:

$$f(\theta) = \left| \cos\left(\frac{2\pi}{\lambda}h\right) \right| \times |1 + e^{j\left(\frac{2\pi}{\lambda}d \sin \phi\right)}| \quad (12)$$

Let $\phi = 0^\circ$ the directional function of the double-whip antenna in the vertical direction (xoz) can be expressed as:

$$f(\theta) = 2 \left| \frac{\cos\left(\frac{2\pi}{\lambda}h \cos \theta\right) - \cos\left(\frac{2\pi}{\lambda}h\right)}{\sin \theta} \right| \quad (13)$$

Let $\phi = 90^\circ$ the directional function of the double-whip antenna in the vertical direction ($yozy$) can be expressed as:

$$f(\theta) = \left| \frac{\cos\left(\frac{2\pi}{\lambda}h \cos \theta\right) - \cos\left(\frac{2\pi}{\lambda}h\right)}{\sin \theta} \right| \times |1 + e^{j\left(\frac{2\pi}{\lambda}d \sin \theta\right)}| \quad (14)$$

3. DESIGN OF DOUBLEWHIP ANTENNA

Although increasing from singlewhip to double-whip can effectively improve the radiation performance of antenna, the height of double-whip antenna is still far less than one quarter of the wavelength in low frequency band, and impedance matching problem still exists. Therefore, it is necessary to reanalyze the structure of double-whip antenna, and redesign and re-optimize a new type of double-whip antenna with high gain.

3.1. Structural Analysis

For the design of double-whip antenna, on the one hand, the broadband characteristics of the antenna should be considered; on the other hand, the gain, efficiency, and pattern of the antenna should be considered too. In the whole VHF band, for whip antenna with standing-wave current distribution, the limitation of its working frequency band is mainly caused by its impedance characteristics. The input impedance of double-whip antenna is sensitive to the change of frequency and fluctuates greatly in the whole VHF band. This brings great difficulties to impedance matching between antenna and feeder, but lumped element loading can be used to make the antenna have better traveling wave characteristics. Reactance-loaded antenna has high efficiency while its bandwidth is narrow, and resistance-loaded antenna has low efficiency but with wide bandwidth. Therefore, the contradiction between bandwidth and efficiency can be alleviated by loading resistance and reactance components simultaneously.

It can be seen from Equation (9) that the spacing between antenna 1 and antenna 2 has a great relationship with their antenna patterns, which will directly affect the omnidirectional radiation of the antenna. In FEKO, a 13 meters double-whip antenna model shown in Fig. 1 is set up. The input impedance and VSWR of the double-whip antenna are simulated under different spacings d , as shown in Fig. 3 and Fig. 4. The input impedance of the double-whip antenna varies greatly with frequency. In the low frequency, the input resistance is still very low, the capacitive resistance very large, and the antenna's VSWR very high, so it is very difficult to realize the impedance matching between the antenna and the feeder. The larger the antenna spacing is, the smaller the fluctuation range of the antenna input impedance is, and the smaller the VSWR is.

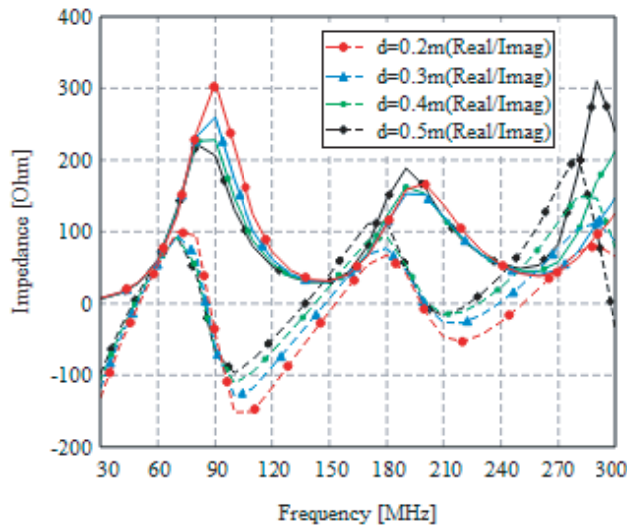

Figure 3. Input impedance of double-whip antenna with different d .

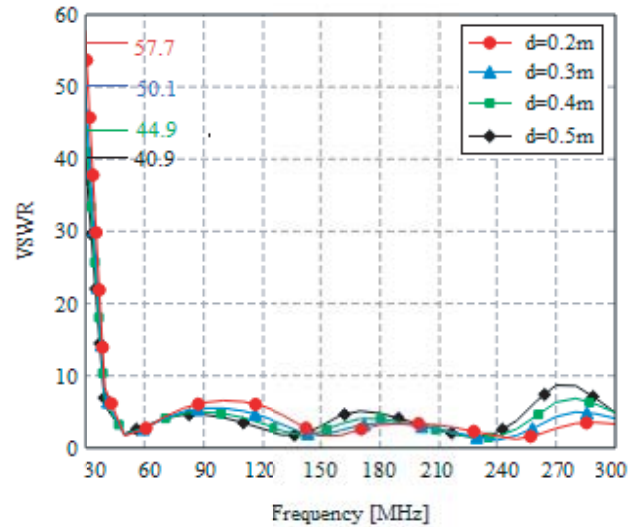

Figure 4. The VSWR of double-whip antenna with different d .

The horizontal patterns of the double-whip antenna at different frequencies and spacings are shown in Fig. 5. The maximum gain, minimum gain, and their difference of the horizontal pattern of the double-whip antenna are shown in Table 1. It can be concluded that the higher the frequency is, the greater the non-circularity of the antenna pattern is; and the larger the spacing d is, the greater the

Table 1. Non-roundness of gain pattern of double-whip antenna.

Frequency	d (m)	G_{\max} (dB)	G_{\min} (dB)	$G_{\max} - G_{\min}$ (dB)
30 MHz	0.2	4.89	4.87	0.02
	0.3	4.90	4.86	0.04
	0.4	4.91	4.84	0.07
	0.5	4.92	4.82	0.10
150 MHz	0.2	6.59	6.12	0.47
	0.3	6.91	5.82	1.09
	0.4	7.38	5.39	1.99
	0.5	7.99	4.73	3.26
300 MHz	0.2	5.43	3.69	1.74
	0.3	6.02	1.60	4.42
	0.4	6.43	-3.71	11.14
	0.5	6.39	-19.97	26.36

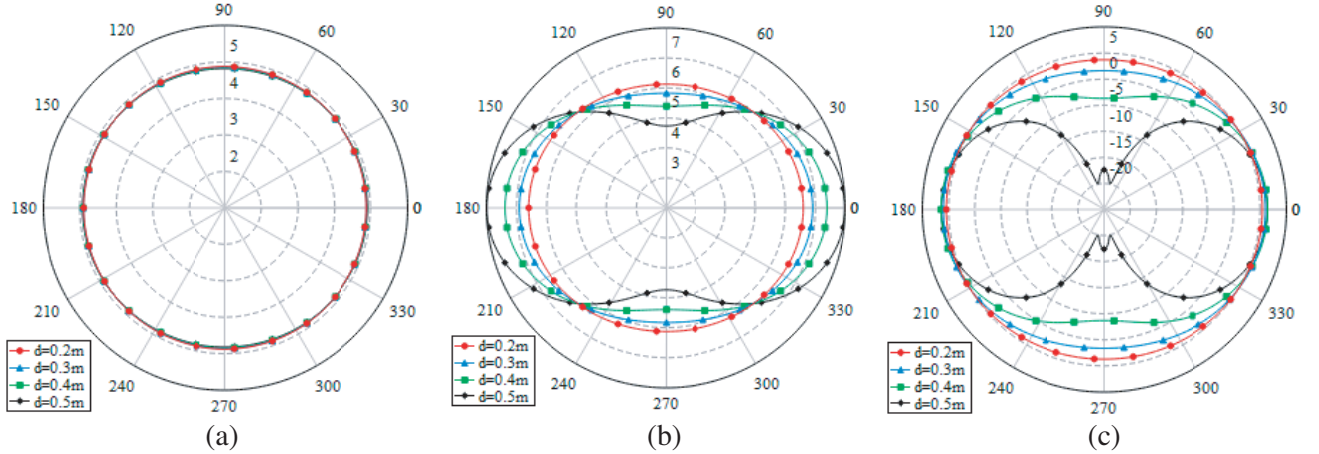

Figure 5. Horizontal pattern of double-whip antenna at different spacing, (a) 3 MHz, (b) 15 MHz, (c) 300 MHz.

non-circularity of the antenna pattern is. When the frequency is 3 MHz, the horizontal pattern of the double-whip antenna basically keeps omnidirectional, but with the increase of frequency, the non-circularity of the pattern of the double-whip antenna increases gradually. The larger the distance d is, the greater the non-circularity of the pattern of the double-whip antenna is, and the more obvious the directivity of the double-whip antenna with large distance appears in the high frequency band, which is not conducive to the omnidirectional radiation.

3.2. Antenna Structure

For the bottom-fed double-whip antenna, the distribution current on the antenna decreases with the increase of the antenna. Therefore, the resistance loading used to improve the broadband characteristics should be set at the upper part of the antenna, not at the bottom of the antenna. The current at the bottom of the antenna is particularly high. Resistance loading will increase the loss of the antenna and reduce the efficiency of the antenna. The antenna spacing d has great influence on the radiation performance of the antenna. The larger the spacing d is, the smaller the VSWR will be, but the greater the non-roundness of the pattern is. Therefore, the spacing d should be chosen in a compromise so as to better balance the contradiction between them.

Considering the above, the height of the double-whip antenna is 13 meters, and the distance d is 0.3 meters. A lumped loading network is added at 25% of the distance from the top of the antenna. A “T” matching network is added at the bottom of the antenna, which is composed of a transmission line transformer and reactor elements, as shown in Fig. 6.

3.3. Optimal Design

In this paper, grasshopper optimization algorithm (GOA) [15–17] is introduced to optimize the loading network and the broadband matching network of the double-whip antenna as shown in Fig. 6, and to enhance the gain of the antenna under the premise that the minimum VSWR in more frequency points is less than 3. For the loading network, minimizing the maximum VSWR and maximizing minimum gain in the ultrashort wave band are used as the objective function of the algorithm optimization calculation [17, 18]

$$F = \min \left\{ \sum_{i=1}^n \left[W_i (VSWR(\omega_i) - 1)^2 + A_i (G_0 - G(\omega_i)) \right] \right\} \quad (15)$$

where $G(\omega_i)$ is the gain of antenna at ω_i , and G_0 is the rated gain, which is an adjusting parameter to weigh the broadband impedance characteristics and gain characteristics of antenna. W_i is the weighted value of VSWR at each frequency point, whose value depends on the relative importance of $VSWR(\omega_i)$.

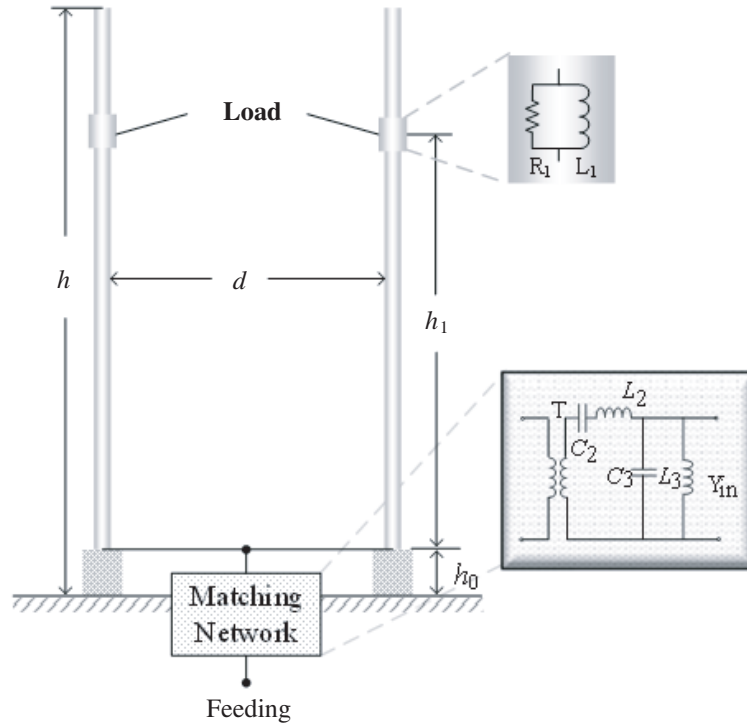

Figure 6. The proposed double-whip antenna structure.

On the one hand, it retains a good VSWR, and on the other hand, it discards a bad VSWR. Obviously, the smaller the value of the objective function is, the better the optimization effect is.

The objective function of the matching network should minimize the average VSWR in the ultrashort wave band.

$$F = \min \left[\frac{1}{n} \sum_{i=1}^n VSWR(\omega_i) \right] \tag{16}$$

After several optimizations by GOA, the optimum results of the double-whip antenna are obtained. The optimum values of each element are shown in Table 2. The input impedances and VSWRs of the double-whip antenna before and after setting and optimizing loading and matching network are shown in Fig. 7 and Fig. 8, respectively. From the figures, it can be seen that the input impedance of the double-whip antenna becomes more stable, and the VSWR becomes smaller in the whole frequency band after loading and matching network. Loading realizes the rough matching of the double-whip antenna, and matching network makes the antenna get further matching. Finally, the input resistance of the antenna is closer to 50 Ω, and the input reactance is closer to 0 Ω, so that the impedance matching between the antenna and the feeder can be better realized.

Table 2. Optimal values of double-whip antenna.

R_1/Ω	$L_1/\mu\text{H}$	L_2/nH	C_2/nF	$L_3/\mu\text{H}$	C_3/pF	T
300	15	111	560	1.9	130	2.5

4. ANTENNA MEASUREMENT AND ANALYSIS

In order to better verify the performance of the double-whip antenna mentioned in this paper, a 13-meter double-whip antenna is fabricated. As shown in Fig. 9, the height of the antenna is 1.3 m; the radius of

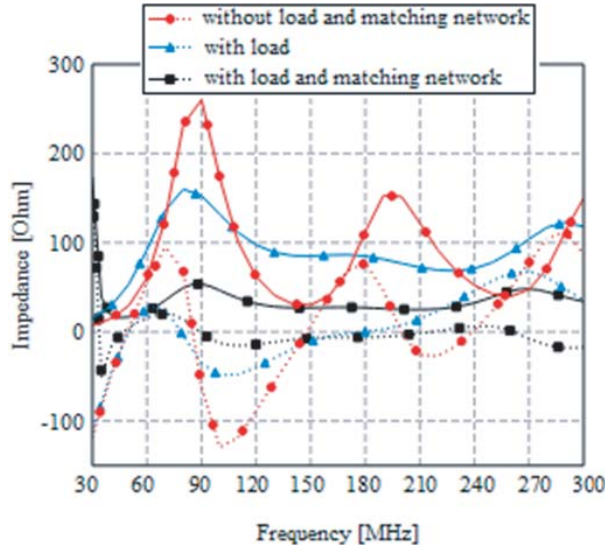

Figure 7. Comparison of input impedance before and after optimization.

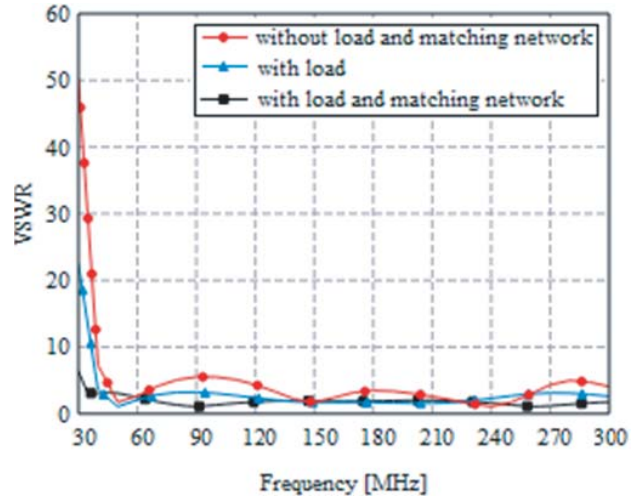

Figure 8. Comparison of VSWR before and after optimization.

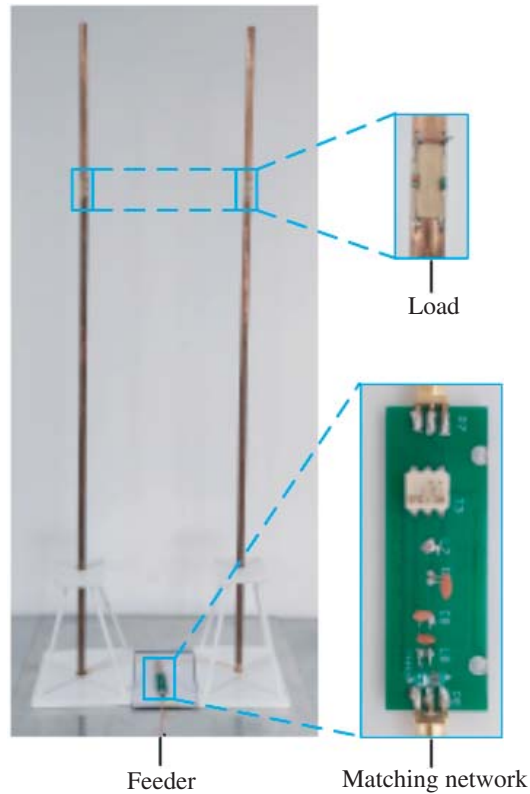

Figure 9. The fabricated prototype of the proposed antenna.

the antenna is 0.5 cm; and the distance between the two whips is 0.3 m. An RL parallel loading network is added at 0.25 m from the top of the antenna, and a transmission line transformer and reactor group are installed at the bottom of the antenna. The “I” shaped broadband matching network is formed and fed by a combined bottom end. The measured antenna performance parameters are compared with the simulation results, as shown in Fig. 10.

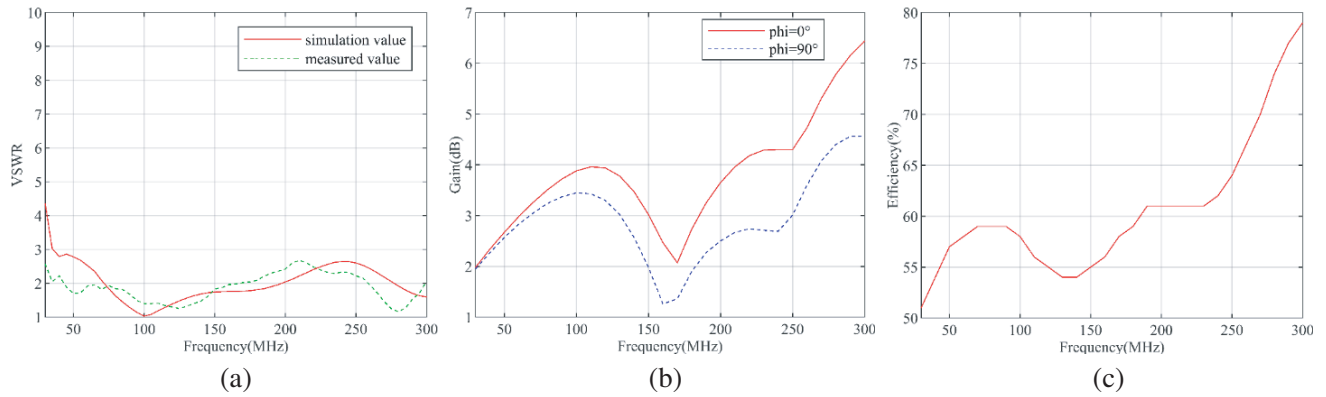

Figure 10. Performance curves of the proposed double-whip antenna. (a) VSWR. (b) Gain. (c) Efficiency.

From Fig. 10, it can see that the simulated VSWR at 98% frequency points is less than 3; the average value is 2.03; the test value is basically consistent with the simulation value, and all are less than 3; the average value is 1.89, which is better than the simulation value, especially in the low frequency band. The main reason is that the nonlinearity and loss of the core in the transmission line transformer can slow down the high capacitance reactance at the input of the low frequency antenna, so that the test value of the actual antenna in the low frequency section gets better performance. Fig. 10(b) shows the gain of the antenna in both directions $\phi=0^\circ$ and $\phi=90^\circ$. The gain of each frequency in the maximum direction is greater than 2 dB, and the maximum gain of 6.44 dB appears in the frequency of 300 MHz, with an average value of 3.79 dB. The minimum non-circularity of the antenna gain is 0.03 dB (at 3 MHz), and the maximum non-circularity is 1.87 dB (at 30 MHz). As shown in Fig. 11 and Table 3, the horizontal pattern of the antenna remains omnidirectional in low frequency band, and with the increase of the frequency, the non-roundness of antenna gain increases, but the maximum value is much less than 3 dB. Fig. 10(c) shows that the efficiency of the proposed antenna is all greater than 51%; the maximum value is 79%; and the average value is 60.71%. This is mainly due to the reduction of the impedance loading of the double-whip antenna, which reduces the resistance loss, especially the abandonment of the impedance loading elements at the low end of the antenna, and improves the radiation efficiency.

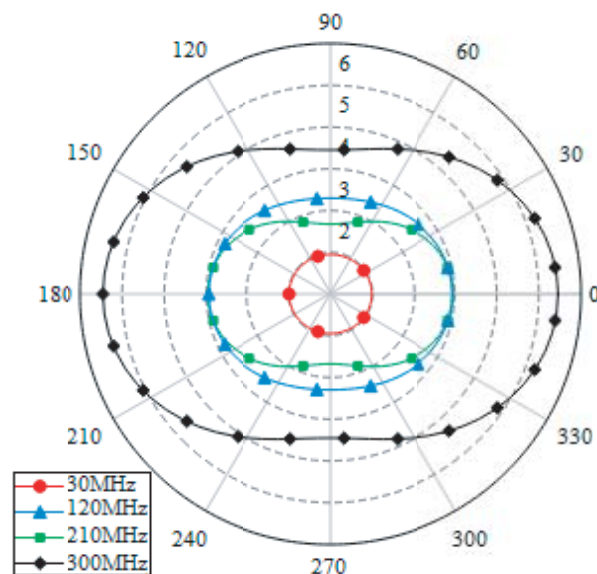

Figure 11. The pattern of the proposed double-whip antenna.

Table 3. Non-roundness of gain pattern of the proposed double-whip antenna.

Frequency (MHz)	30	50	70	90	110	130	150	170	190	210	230	250	270	300
G_{\max} (dB)	2.01	2.67	3.26	3.72	3.96	3.78	3.02	2.07	3.25	3.96	4.29	4.30	5.31	6.44
G_{\min} (dB)	1.98	2.57	3.05	3.37	3.43	3.02	1.98	1.36	2.27	2.67	2.71	3.01	4.08	4.57
ΔG (dB)	0.03	0.10	0.21	0.35	0.53	0.76	1.04	0.71	0.98	1.29	1.58	1.29	1.23	1.87

5. CONCLUSION

In this paper, a VHF double-whip antenna based on moment method is proposed. The antenna system has the following advantages: Firstly, its size is very small, and the electric length of two whips is far less than $1/4$ wavelength of the minimum frequency, which is convenient for mobile platform to use, and conducive to the concealment requirements of vehicle and ship. Secondly, it has a very wide working frequency band, covering the high frequency band from 3 to 30 MHz. The average VSWR measured is less than 2. Thirdly, compared with other lossy matching methods, our lossless matching method achieves higher horizontal gain ranging from 2.01 to 6.44 dB in the working frequency band. The proposed double-whip antenna can be widely used in high gain, broadband vehicle, shipboard, and civil mobile communications.

REFERENCES

1. Mohammad, B., A. B. Mehdi, and M. A. Karim, "Design of a low-cost broadband loaded dipole antenna for VHF/UHF frequency range," *IET Microwaves, Antennas & Propagation*, Vol. 13, No. 12, 1983–1988, 2019.
2. Rogers, S. D., C. M. Butler, and A. Q. Martin, "Design and realization of GA-optimized wire monopole and matching network with 20 : 1 band-width," *IEEE Transactions on Antennas and Propagation*, Vol. 51, No. 3, 493–502, Mar. 2003.
3. Yegin, K. and A. Q. Martin, "Very broadband loaded monopole antennas," *Proc. IEEE Antennas and Propag. Soc. Int. Symp.*, Vol. 1, 232–235, Montreal, QC, Canada, Jul. 1997.
4. Ding, X., B.-Z. Wang, G. Zheng, and X.-M. Li, "Design and realization of a GA-optimized VHF/UHF antenna with 'on-body' matching network," *IEEE Antenna Wireless Propag. Lett.*, Vol. 9, 303–307, 2010.
5. Lizuka, H. and P. S. Hall, "Left-handed dipole antennas and their implementations," *IEEE Transactions on Antennas and Propagation*, Vol. 55, No. 5, 1246–1253, 2007.
6. Abramo, R., "Broadband, high-power, 2–30 MHz, twin-whip antenna. Computer and 1/10-scale model design study," *Final Report Naval Command, Control and Ocean Surveillance Center, San Diego, CA. RDT and E. Div.*, Jan. 1994.
7. Liang, X. U., "Novel VHF broadband twin-whip antenna," *Chinese Journal of Radio Science*, Vol. 24, No. 6, 1125–1128, 2009.
8. Ding, X., B. Z. Wang, G. D. Ge, et al., "A broadband VHF/UHF double-whip antenna," *IEEE Transactions on Antennas and Propagation*, Vol. 60, No. 2, 719–724, 2012.
9. Sun, B.-H. and Q.-Z. Liu, "A new technique for the efficient MoM analysis of wire antennas," *Journal of Xidian University*, Vol. 28, No. 4, 487–491, 2001.
10. Wang, H. F., C. Liu, and H. N. Wu, "HF wideband whip antenna optimization based on invasive weed optimization algorithm," *Radio Engineering*, Vol. 46, No. 11, 63–67, 2016.
11. Bod, M., M. Ahmadi-Boroujeni, and K. Mohammadpour-Aghdam, "Broadband loaded monopole antenna with a novel on-body matching network," *AEU — International Journal of Electronics and Communications*, Vol. 70, No. 11, 1551–1555, 2016.

12. Manoochehri, O., M. A. Salari, and A. Darvazehban, "A short broadband monopole antenna," *AEU — International Journal of Electronics and Communications*, Vol. 83, 240–244, 2018.
13. Sengül, M., "Design of broadband single matching networks," *AEU — International Journal of Electronics and Communications*, Vol. 63, No. 3, 153–157, 2009.
14. Burke, G. J. and A. J. Poggio, "Numerical Electromagnetics Code (NEC) method of moments," *Rep. UCID 18834*, Lawrence Livermore Lab, CA, Jan. 1981.
15. Saremi, S., S. Mirjalili, and A. Lewis, "Grasshopper optimisation algorithm: Theory and application," *Advances in Engineering Software*, Vol. 105, 30–47, 2017.
16. Mirjalili, S. Z., S. Mirjalili, S. Saremi, et al., "Grasshopper optimization algorithm for multi-objective optimization problems," *Applied Intelligence*, No. 3, 1–16, 2017.
17. Wang, H., C. Liu, H. Wu, and X. Xie, "A novel frequency reconfigurable HF broadband whip antenna based on GOA optimization," *Progress In Electromagnetics Research M*, Vol. 87, 11–21, 2019.
18. Wang, H. F., C. Liu, H. N. Wu, and X. Xie, "Optimization design of short wave broadband whip antenna loaded with radiation lobes," *Journal of National University of Defense Technology*, Vol. 41, No. 5, 159–165, 2019.