

Two Port Compact MIMO Antenna for ISM Band Applications

Kanhaiya Sharma^{1, *} and Ganga Prasad Pandey²

Abstract—This article presents a compact size and high isolation 2×2 , Multi-Input Multi-Output (MIMO) antenna for Industrial Scientific and Medical (ISM) band and 5G lower frequency band of 5G applications. Mutual coupling has been a great challenge in these applications. To improve isolation between elements of 2×2 MIMO antennas, a mushroom-shaped electromagnetic bandgap (EBG) and a fractal shaped EBG have been investigated. The overall size of the proposed antenna is $38.2 \times 95.94 \times 1.6 \text{ mm}^3$ with inter-element spacing (edge to edge) of 0.140λ . The proposed antenna has been designed, simulated, fabricated, and tested. The resulting outcome shows that the antenna operates in the band of 2.43–2.50 GHz and radiates in TM_{10} mode. By using fractal shaped EBG, isolation of -24.67 dB is achieved. Apart from isolation, other performance parameters of the MIMO antenna are verified. The proposed antenna is suitable for weather radar, surface ship radar, satellite communication, and wireless local area network (WLAN) applications.

1. INTRODUCTION

In recent years, there is an advancement in technology that leads to continuous improvement in the coverage, capacity of the wireless communication network, throughput, and consumer experience through advanced antenna systems (AASs). AASs include mmWave communication, beamforming, and multiple-input multiple-output (MIMO). By improving the signal quality, MIMO system can effectively enhance throughput, system capacity, quality of service (QoS), minimize fading effects, lower susceptibility of tapping, and improve system coverage. Microstrip antenna has numerous advantages over other types of antennas like easy fabrication, low cost, compact size, multiband capability, supporting linear and circular polarizations, and can be mounted on a rigid surface. In the case of microstrip MIMO antennas, the leading cause of mutual coupling is surface waves. There is a trade-off between coupling and size of overall MIMO antenna. Due to the limited space, a compact antenna with high isolation is preferred for MIMO communication. The effect of mutual coupling (MC) on the MIMO antenna was investigated in [1]. Various techniques of reducing mutual coupling in a MIMO antenna have been studied in [2–4]. Researchers have investigated different MC reduction techniques to achieve optimum MC. Mostly preferred and frequently used MC techniques are presented here. For example, use of a defected ground structure (DGS) can reduce MC up to -55 dB [5]; dielectric resonator antenna can reduce MC up to -25 dB [6], complementary split-ring resonator (CSRRLs) can reduce MC up to -22 dB [7], neutralization lines reduce MC up to -23 dB [8, 9], engineered parasitic patch or slot element can reduce MC by -22 dB [10], reconfigurable antenna can reduce MC up to -47 dB [11], electromagnetic bandgap (EBG) can reduce MC up to -53.7 dB [12], engineered metamaterial can reduce MC up to -42 dB [13], and decoupling networks can reduce MC up to -32 dB [14], respectively. DGS and EBG are preferred methods to reduce MC. Some of the advancements in metasurfaces like realizations of various polarization-independent properties for all

Received 15 January 2020, Accepted 5 March 2020, Scheduled 17 March 2020

* Corresponding author: Kanhaiya Sharma (sharmakanhaiya@gmail.com).

¹ Department of Computer Science and Engineering, Pandit Deendayal Petroleum University, Raisan, Gandhinagar, Gujarat 382007, India. ² Department of Information and Communication Technology, Pandit Deendayal Petroleum University, Raisan, Gandhinagar, Gujarat 382007, India.

frequency spectra were studied in [15, 16]. In the present study, the authors investigate different EBG structures on a simple microstrip antenna to reduce MC between elements of 2×2 MIMO antenna for 5G communication. The investigation starts with a single microstrip antenna design at 2.4 GHz, then a 2×2 MIMO antenna design without EBG is investigated. The model of a mushroom-shaped EBG and bridge structure is studied. Then the model of a fractal-shaped EBG structure is designed, and finally, a 2×2 MIMO antenna with a fractal-shaped EBG structure is designed and investigated.

2. ANTENNA DESIGN

2.1. Single Antenna Design

To design the proposed antenna, first of all dimensions of a $28.6 \times 38.37 \times 1.6 \text{ mm}^3$ rectangular patch antenna is designed at 2.4 GHz and simulated using CST. FR-4 ($\epsilon_r = 4.4$) material is used to design the antenna which is fed with inset feed. The dimension of the ground plane is taken as $38.2 \times 47.97 \text{ mm}^2$. The design parameters of single patch antenna are tabulated in Table 1, and the design structure is

Parameter	Value
Operating frequency	2.4 GHz
Patch length (L)	28.6 mm
Patch width (W)	38.37 mm
Substrate thickness (h)	1.6 mm
Dielectric constant (ϵ_r)	4.4
Ground length (L_g)	38.2 mm
Ground width (W_g)	95.94 mm
Feed type	Inset
Feed length (L_f)	10 mm
Feed width (W_f)	3.08 mm
Realized Gain	4.253 dBi
Operating mode	TM ₁₀
Directivity	5.37 dBi
Radiation efficiency	91.71% dBi
Total efficiency	77.18% dBi

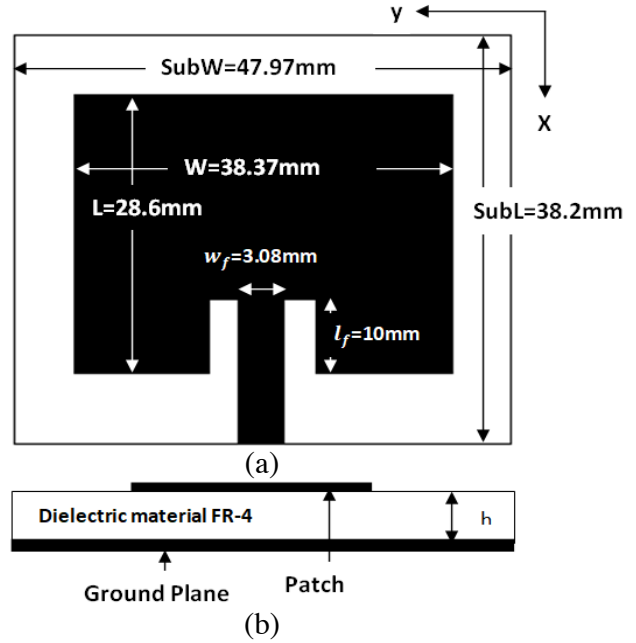

Table 1. Physical and electrical parameters of single patch antenna.

Figure 1. (a) Front view, (b) side view of rectangular microstrip antenna.

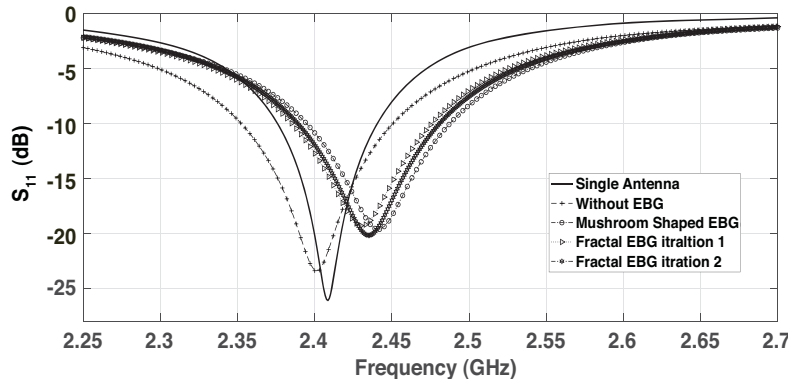

Figure 2. S_{11} parameter plot for 2×2 MIMO antenna.

shown in Figure 1. The return loss variation with frequency is shown in Figure 2. It is clear from Figure 2 that the designed antenna is properly matched and resonates at 2.4 GHz with S_{11} value -26.01 dB.

2.2. Design of a 2×2 Antenna without EBG Structure

There is a trade-off between antenna size and mutual coupling. For a MIMO antenna, it is a challenge to design a compact antenna with low mutual coupling. To design a 2×2 MIMO antenna, investigation starts with two identical elements with inter-antenna spacing (edge to edge) of 0.14λ , and the overall size of antenna is 38.2×95.94 mm². The design structure of the 2×2 MIMO antenna without an EBG structure is shown in Figure 3. The variation of transmission parameters (S_{21}) of different stages of the evolution of the antenna system is shown in Figure 4, from which it is clear that the simulated mutual coupling between two antennae is -19.35 dB.

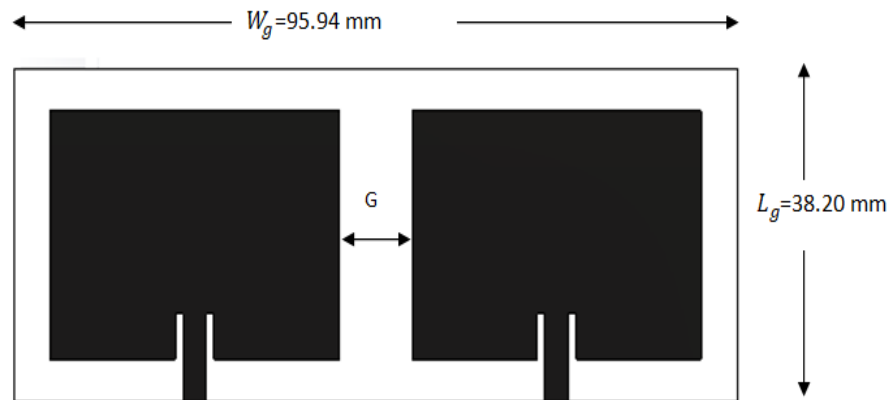

Figure 3. 2×2 MIMO antenna without an EBG structure.

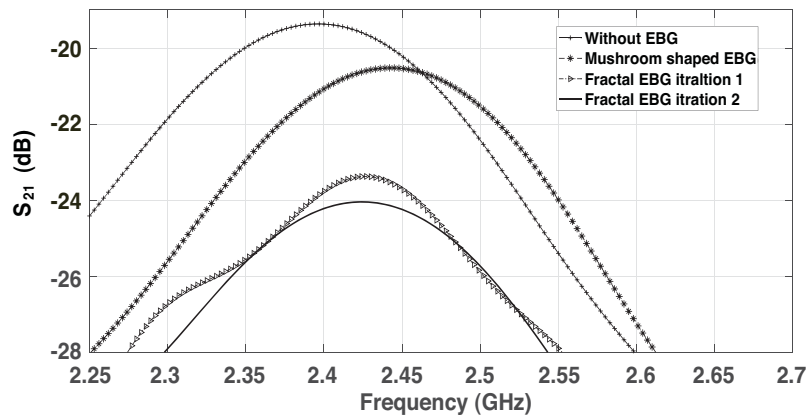

Figure 4. S_{21} parameter plot for 2×2 MIMO antenna.

3. DESIGN OF DECOUPLING STRUCTURE

To improve isolation between two elements of the MIMO antenna, mushroom-shaped EBG and fractal-shaped EBG structures are investigated.

3.1. Mushroom Shaped EBG Structure

A mushroom type EBG structure is designed at 2.4 GHz and used in the center of two radiating elements. The analysis of a mushroom type EBG structure is investigated in [17]. The square patch of side 4 mm

is created, and in the center of the square patch, a via of diameter 0.7 mm is created, which extends up to ground. To connect one mushroom structure with the other structure, bridge structure of dimension, $0.25 \times 1 \text{ mm}^2$ is designed. Two mushroom-shaped EBG structures are placed at a distance of 5 mm from each other as shown in Figure 5. The eight square patches and seven connecting bridges are designed and optimized to achieve the best isolation for the 2×2 MIMO antenna designed earlier. The complete structure is shown in Figure 6.

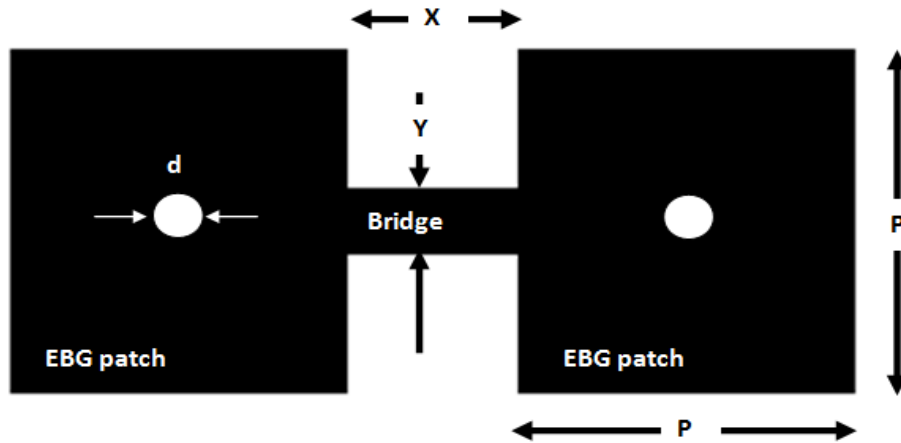

Figure 5. Bridge connection between two unit cells.

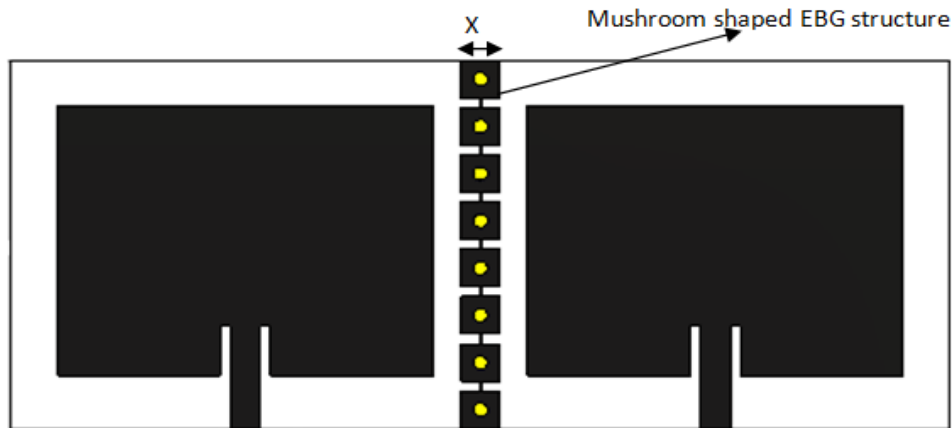

Figure 6. 2×2 MIMO antenna with mushroom-shaped EBG.

3.2. Fractal Shaped EBG

The first iteration of fractal-shaped EBG antenna is designed by creating an annular square slot of width 0.5 mm. The outer side of rotated square is 2.82 mm while the slot is configured within outer boundary of square by a gap of 0.38 mm. Second order fractal is obtained by putting another annular rotated slot with 0.5 mm slot width and 1.41 mm side. The gap between big and small annular rotated squares is kept as 0.5 mm. Two fractal-shaped EBG structures are placed at a distance of 4.5 mm apart from each other. The dimensions of fractal-shaped EBG structure is optimized to achieve the least mutual coupling between elements of MIMO antennas. The fractal-shaped EBG structures are shown in Figures 7 and 8 for the 1st and 2nd iterations, respectively.



Figure 7. Fractal shaped EBG iteration 1.

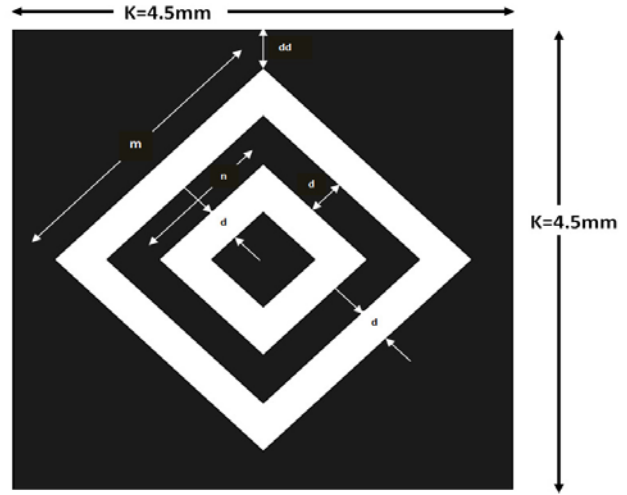

Figure 8. Fractal shaped EBG iteration 2 (dimensions are $m = 2.82$ mm, $n = 1.41$, $d = 0.5$ mm, $dd = 0.38$ mm).

4. DESIGN AND ANALYSIS OF 2×2 MIMO ANTENNA WITH FRACTAL EBG

Two different EBG structures are investigated to improve isolation between two elements of MIMO antenna. In the first case, 8 EBG structures and seven bridges are placed in the center of the gap between antennas. All EBG patches are shorted with the ground using vias of diameter $d = 0.7$ mm. In the second case, eight fractal-shaped EBG structures are placed in the center. The stepwise detailed design structures are shown in Figures 9 and 10 using the 1st and 2nd order fractal-shaped EBG.

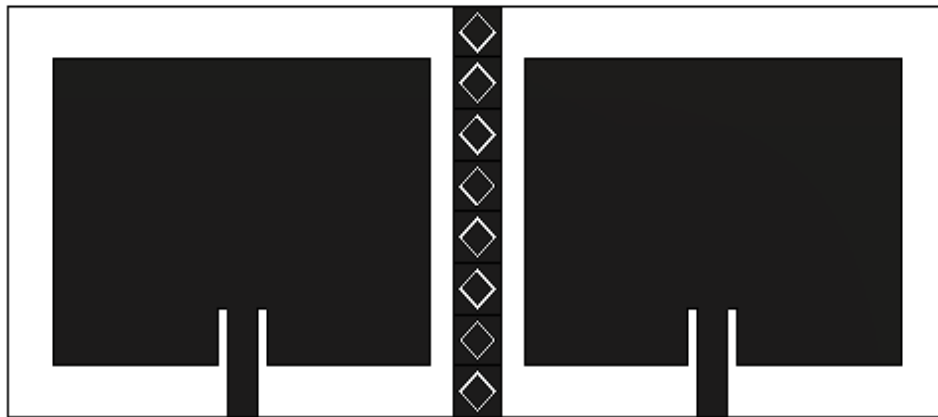

Figure 9. 2×2 MIMO antenna with the 1st iteration fractal EBG.

4.1. Current Distribution

The decoupling effect at 2.44 GHz between port 1 and port 2 is shown in Figures 11 and 12. The figures show that the current density at port 1 is intensive when it is excited, and port 2 is matched with 50Ω load or vice versa. It may be concluded that the current is effectively reduced by a mushroom-shaped EBG structure. It is also clear from Figures 11 and 12 that in both cases, 2×2 MIMO antenna radiates in dominant mode TM_{100} in the band of 2.39 to 2.48 GHz.



Figure 10. 2×2 MIMO antenna with the 2nd iteration fractal EBG.

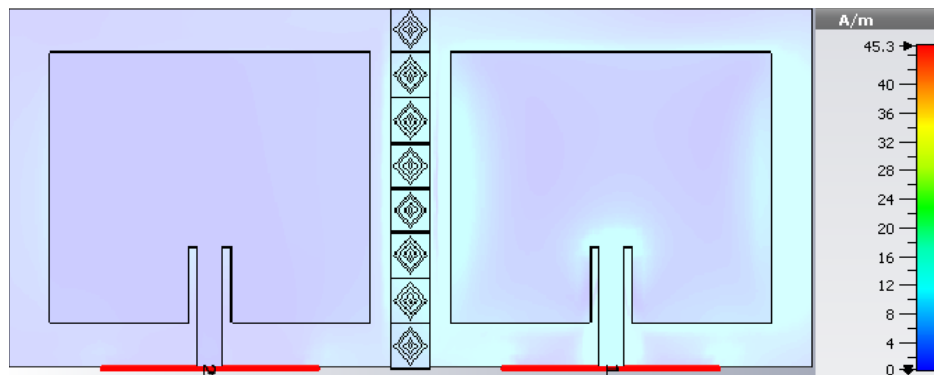

Figure 11. Current distribution at 2.44 GHz when Port 1 is excited and Port 2 matched.

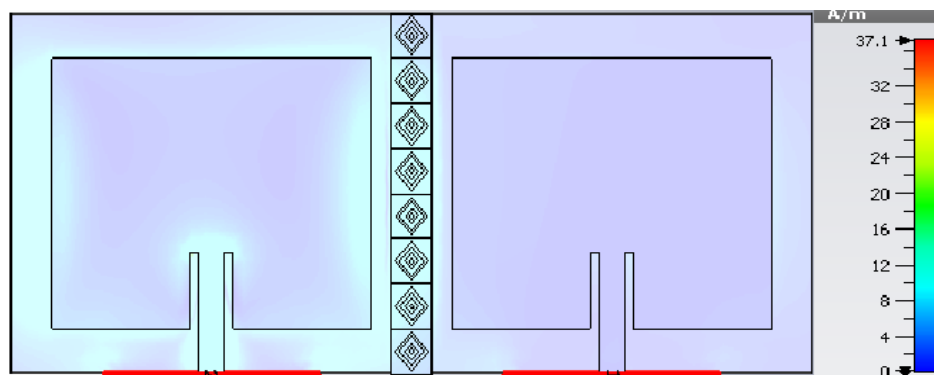

Figure 12. Current distribution at 2.44 GHz when Port is excited and Port matched.

4.2. S -Parameters and Excitation Mode

The variation of S_{11} with frequency for a single antenna, 2×2 MIMO without EBG and with mushroom-shaped EBG and with fractal-shaped EBG is shown in Figure 2. By observing this figure, it is clear that the single patch antenna radiates at 2.40 GHz; 2×2 MIMO antenna without EBG radiates at 2.40 GHz, with mushroom-shaped EBG, 2×2 MIMO antenna radiates at 2.44 GHz; and with fractal shaped EBG MIMO antenna of first and second iteration fractals radiates at 2.43 GHz and 2.43 GHz, respectively. It may be concluded that after applying an EBG structure frequency shifts from 2.40 GHz

Table 2. Radiation pattern parameters for 2×2 MIMO antenna.

Parameter	Without EBG	With EBG	Fractal EBG Iteration 1	Fractal EBG Iteration 2
3 dB Beamwidth	59.3°	103.1°	59.6°	59.8°
Mainlobe dir.	0.0°	8.0°	0.0°	0.0°
SLL	-8.8 dB	-8.2 dB	-8.3 dB	-8.2 dB

to 2.44 GHz due to coupling. The separation between two elements of the MIMO antenna is 0.14λ , which reduces the size of the 2×2 MIMO antenna. Without using an EBG structure, the isolation between two elements of MIMO is -19.35 dB. By introducing a mushroom-shaped EBG structure in between two elements of MIMO antenna, the isolation value is improved to -21.30 dB, using first-order fractal isolation improved to -23.449 dB, and finally, using the 2nd order fractal shaped EBG, the isolation between two elements of MIMO antenna becomes -24.05 dB. The proposed antenna radiates at 2.44 GHz, and impedance bandwidth of the simulated antenna is 81.3 MHz ranging from 2.39 to 2.48 GHz. Throughout impedance bandwidth, the simulated isolation value for the proposed 2×2 MIMO antenna is -24.05 dB. The proposed fabricated antenna is shown in Figure 13. The simulated and measured results of S_{11}/S_{22} and isolation (S_{12}/S_{21}) are shown in Figure 14. The fabricated antenna operates around 2.47 GHz, and minimum isolation of -24.67 dB is obtained.

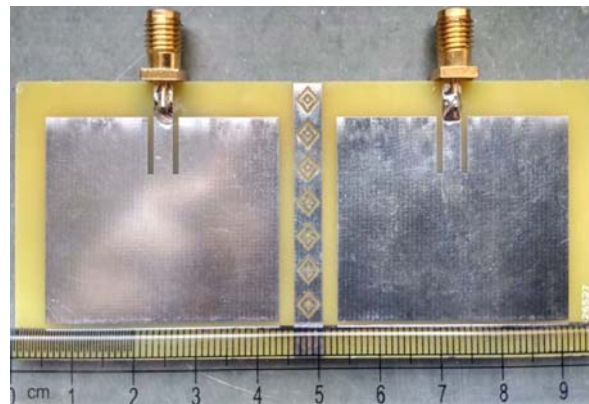

Figure 13. Fabricated 2×2 MIMO antenna.

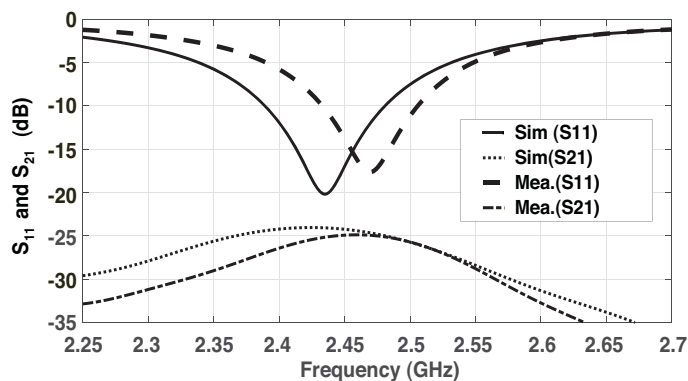

Figure 14. Simulated and measured S parameters.

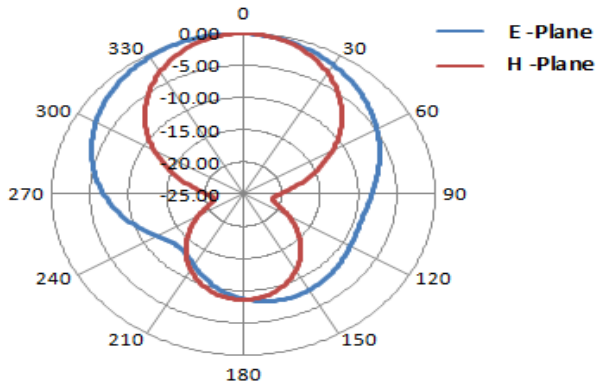

Figure 15. Radiation pattern at 2.44 GHz without EBG structure.

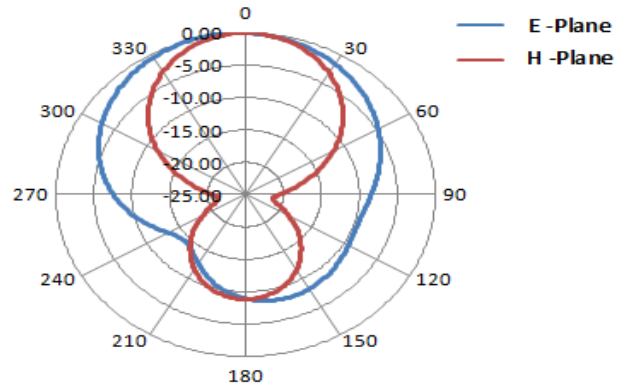

Figure 16. Radiation pattern at 2.44 GHz with EBG structure.

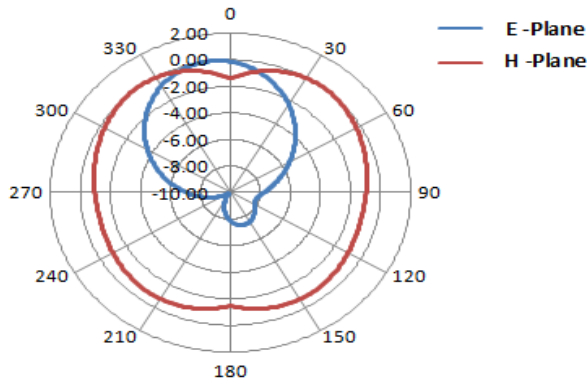

Figure 17. Radiation pattern at 2.44 GHz with fractal shaped EBG structure iteration 1.

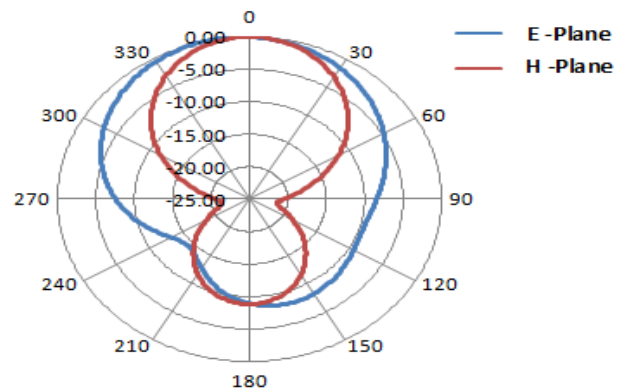

Figure 18. Radiation pattern at 2.44 GHz with fractal shaped EBG structure iteration 2.

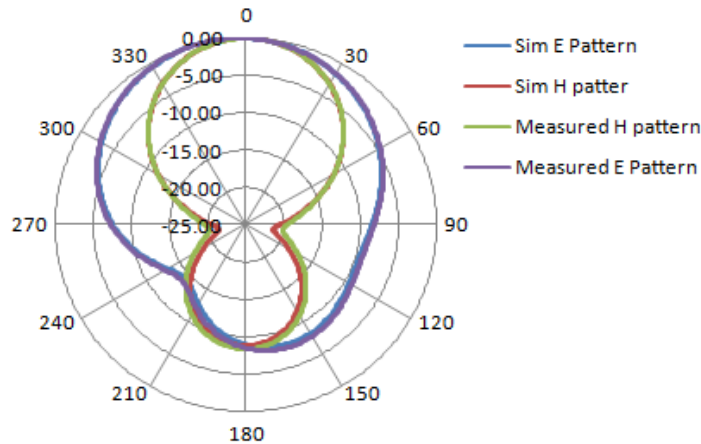

Figure 19. Simulated and measured radiation pattern at 2.47 GHz.

4.3. Radiation Characteristics

The simulated *E* and *H* field radiation patterns at 2.44 GHz of antenna without and with an EBG structure are shown in Figures 15, 16, 17, and 18. The detailed radiation pattern parameters are tabulated in Table 2. The proposed antenna radiates in broadside, and patterns also suggest for

dominant mode radiation. The measured radiation pattern at 2.47 GHz is shown in Figure 19. The result shows close agreement with simulated pattern.

4.4. Directivity, Realized Gain and Radiation Efficiency

The directivity, realized gain, radiation efficiency, and total radiation efficiency of 2×2 MIMO antenna with or without an EBG are tabulated in Table 3. Due to high dielectric losses, the total efficiency of proposed antenna is approximately 51.50%.

Table 3. Directivity, realized gain and efficiency parameters for 2×2 MIMO antenna.

Parameter	Without EBG	With EBG	Fractal EBG Iteration 1	Fractal EBG Iteration 2
Directivity	7.16 dBi	7.28 dBi	7.08 dBi	7.08 dBi
Realized Gain	4.40 dBi	4.68 dBi	4.27 dBi	4.11 dBi
Rad. efficiency	58.53%	55.29%	54.46%	53.12%
Total efficiency	52.99%	54.99%	52.46%	50.46%

4.4.1. Envelope Correlation Coefficient (ECC) and Diversity Gain

The ECC (ρ) is one of the diversity parameters of the MIMO antenna, which illustrates the correlation between radiating elements of the MIMO antenna. The acceptable value of ρ is ≤ 0.5 , and diversity gain is ≥ 9.95 dB. In this investigation, we use FR-4 material which is lossy, so to calculate ECC far field radiation patterns are preferred for printed antenna, and details of calculating ECC are investigated in [35]. The details of ECC and DG are given in Table 4. The simulated and measured ECCs and DGs are shown in Figures 20 and 21, respectively. The measured and simulated results are close to each other.

Table 4. Diversity parameters for 2×2 MIMO antenna.

Parameter	Without EBG	With EBG	Fractal EBG Iteration 1	Fractal EBG Iteration 2	Measured Result
ECC	0.0186	0.0197	0.018	0.019	0.0080
DG	9.996 dBi	9.995 dBi	9.995 dBi	9.996 dBi	9.998 dBi
MEG	-3.01 dBi	-3.01 dBi	-3.01 dBi	-3.01 dBi	-3.03 dBi

4.4.2. Diversity Parameters

Various diversity parameters like ECC, DG, and MEG define the performance of a MIMO antenna, and simulated diversity parameters are obtained using CST Microwave Studio 2019.

4.4.3. Mean Effective Gain

Mean effective gain (MEG) is the ratio of accepted mean power to the average incident power by the radiating element of MIMO as compared to an isotropic antenna. In MEG difference between two ports must be < -3 dB, and the value of MEG for 2×2 MIMO antennas with or without an EBG structure is -3.01 dB. The details of calculation are given in [36]. The simulated and measured MEGs are very close to each other and shown in Table 4.

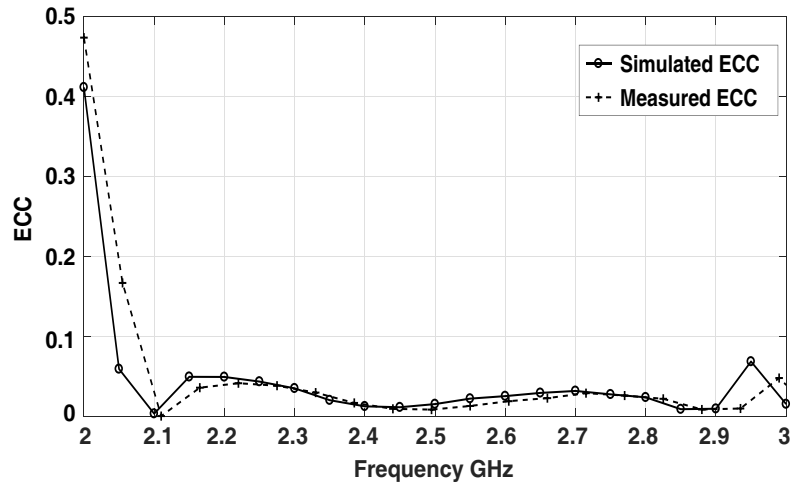

Figure 20. Simulated and measured ECC.

The comparison among the performance parameters of the proposed 2×2 MIMO antenna with earlier works is shown in Table 5. The comparison is done for ECC and isolation. It is clear that the proposed 2×2 MIMO antenna provides better isolation of -24.67 dB with acceptable ECC value of 0.0087.

Table 5. Comparison of proposed 2×2 MIMO antennas with recently reported designs.

References	MIMO	frequency	Isolation	ECC
[9]	2×2	3.51–9.89 GHz & 3.52–10.08 GHz	22 dB	0.039
[18]	2×2	2.4 GHz	15	0.1
[19]	2×2	2.45 GHz & 5.25 GHz	20 dB	0.01 & 0.19
[20]	2×2	2.4 GHz	19 dB	0.006
[21]	2×2	3.1–5 GHz	22 dB	0.1
[22]	2×2	3.1–10 GHz	23 dB	
[23]	2×2	2.70 GHz & 3.95 GHz	18 dB & 21 dB	0.15
[24]	2×2	3.1–10.6 GHz	20 dB	0.2
[25]	4×4	2.3–2.62 & 3.46–10.3 GHz	18 dB	0.03
[26]	2×2	1.48–3.8 GHz	18 dB	0.01
[27]	2×2	2.35–3.05 & 5.12–5.51	12 dB & 15 dB	0.001
[28]	2×2	2.38–2.47 GHz	20 dB	
[29]	2×2	2.31–2.51 GHz	17 dB	0.01
[30]	2×2	5.2 GHz	11 dB	
[31]	2×2	1.92–2.17 GHz	20 dB	
[32]	2×2	900 MHz	15	
[33]	2×2	2.4–2.84 GHz	15	0.003–0.0011
[34]	2×2	2.02–2.93 GHz & 5.10–6.45 GHz	20 dB	0.005–0.025
Proposed Antenna	2×2	2.43–2.50 GHz	-24.67 dB	0.0087

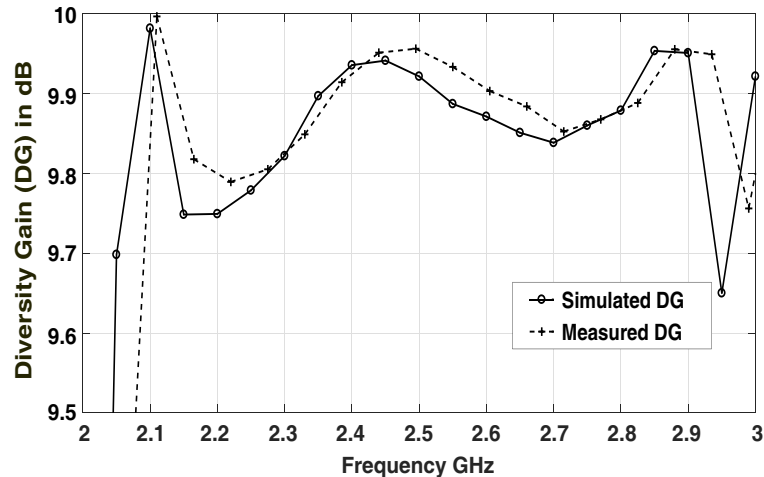

Figure 21. Simulated and measured DG.

5. CONCLUSION

A simple compact fractal EBG based 2×2 MIMO antenna is presented and analyzed, which radiates in TM_{100} mode. The proposed fractal EBG technique is easy to use and provides a better amount of isolation than the mushroom-shaped EBG technique of reducing the mutual coupling between two antennae. An improvement of 3.59 dB in isolation over the mushroom-shaped EBG technique is achieved while maintaining the other MIMO antenna properties. The proposed antenna can be used in various applications of ISM band, WLAN, and various applications of the lower frequency band of 5G.

REFERENCES

- Chen, X., S. Zhang, and Q. Li, "A review of mutual coupling in MIMO systems," *IEEE Access*, Vol. 6, 24706–24719, 2018.
- Malathi, A. C. J. and D. Thiripurasundari, "Review on isolation techniques in MIMO antenna systems," *Indian Journal of Science and Technology*, Vol. 9, No. 35, 2016. [Online]. Available: <http://www.indjst.org/index.php/indjst/article/view/96704>.
- Chouhan, S., D. K. Panda, M. Gupta, and S. Singhal, "Multiport MIMO antennas with mutual coupling reduction techniques for modern wireless transceive operations: A review," *International Journal of RF and Microwave Computer-Aided Engineering*, Vol. 28, No. 2, e21189, 2018. [Online]. Available: <https://onlinelibrary.wiley.com/doi/abs/10.1002/mmce.21189>.
- Shoaib, N., S. Shoaib, R. Y. Khattak, I. Shoaib, X. Chen, and A. Perwaiz, "MIMO antennas for smart 5g devices," *IEEE Access*, Vol. 6, 77014–77021, 2018.
- Wei, K., J. Li, L. Wang, Z. Xing, and R. Xu, "S-shaped periodic defected ground structures to reduce microstrip antenna array mutual coupling," *Electronics Letters*, Vol. 52, No. 15, 1288–1290, 2016.
- Das, G., A. Sharma, and R. K. Gangwar, "Dielectric resonator-based two-element MIMO antenna system with dual band characteristics," *IET Microwaves, Antennas Propagation*, Vol. 12, No. 5, 734–741, 2018.
- Ramachandran, A., S. Valiyaveetil Pushpakaran, M. Pezholil, and V. Kesavath, "A four-port MIMO antenna using concentric square-ring patches loaded with CSRR for high isolation," *IEEE Antennas and Wireless Propagation Letters*, Vol. 15, 1196–1199, 2016.
- Wang, S. and Z. Du, "Decoupled dual-antenna system using crossed neutralization lines for LTE/WWAN smartphone applications," *IEEE Antennas and Wireless Propagation Letters*, Vol. 14, 523–526, 2015.

9. Tiwari, R. N., P. Singh, B. K. Kanaujia, and K. Srivastava, "Neutralization technique based two and four port high isolation MIMO antennas for UWB communication," *AEU-International Journal of Electronics and Communications*, Vol. 110, 152828, 2019. [Online]. Available: <http://www.sciencedirect.com/science/article/pii/S1434841119311227>.
10. Srivastava, G. and A. Mohan, "Compact MIMO slot antenna for UWB applications," *IEEE Antennas and Wireless Propagation Letters*, Vol. 15, 1057–1060, 2016.
11. Lim, J., Z. Jin, C. Song, and T. Yun, "Simultaneous frequency and isolation reconfigurable MIMO PIFA using pin diodes," *IEEE Transactions on Antennas and Propagation*, Vol. 60, No. 12, 5939–5946, Dec. 2012.
12. Lee, J., S. Kim, and J. Jang, "Reduction of mutual coupling in planar multiple antenna by using 1-D EBG and SRR structures," *IEEE Transactions on Antennas and Propagation*, Vol. 63, No. 9, 4194–4198, Sep. 2015.
13. Zhai, G., Z. N. Chen, and X. Qing, "Enhanced isolation of a closely spaced four-element MIMO antenna system using metamaterial mushroom," *IEEE Transactions on Antennas and Propagation*, Vol. 63, No. 8, 3362–3370, Aug. 2015.
14. Zhao, L. and K. Wu, "A dual-band coupled resonator decoupling network for two coupled antennas," *IEEE Transactions on Antennas and Propagation*, Vol. 63, No. 7, 2843–2850, Jul. 2015.
15. Yuan, Y., K. Zhang, X. Ding, B. Ratni, S. N. Burokur, and Q. Wu, "Complementary transmissive ultra-thin meta-deflectors for broadband polarization-independent refractions in the microwave region," *Photon. Res.*, Vol. 7, No. 1, 80–88, Jan. 2019.
16. Zhang, K., Y. Yuan, X. Ding, B. Ratni, S. N. Burokur, and Q. Wu, "High efficiency metalenses with switchable functionalities in microwave region," *ACS Applied Materials & Interfaces*, Vol. 11, No. 31, 28423–28430, 2019.
17. Kim, K. H. and J. E. Schutt-Aine, "Analysis and modeling of hybrid planar-type electromagnetic-bandgap structures and feasibility study on power distribution network applications," *IEEE Transactions on Microwave Theory and Techniques*, Vol. 56, No. 1, 178–186, Jan. 2008.
18. Ryu, J. and H. Kim, "Compact MIMO antenna for application to smart glasses using T-shaped ground plane," *Microwave and Optical Technology Letters*, Vol. 60, No. 8, 2010–2013, 2018.
19. Lin, K., C. Wu, C. Lai, and T. Ma, "Novel dual-band decoupling network for two-element closely spaced array using synthesized microstrip lines," *IEEE Transactions on Antennas and Propagation*, Vol. 60, No. 11, 5118–5128, Nov. 2012.
20. Su, S., C. Lee, and F. Chang, "Printed MIMO-antenna system using neutralization-line technique for wireless USB-dongle applications," *IEEE Transactions on Antennas and Propagation*, Vol. 60, No. 2, 456–463, Feb. 2012.
21. Zhang, S. and G. F. Pedersen, "Mutual coupling reduction for UWB MIMO antennas with a wideband neutralization line," *IEEE Antennas and Wireless Propagation Letters*, Vol. 15, 166–169, 2016.
22. Li, Y., W. X. Li, C. Liu, and T. Jiang, "Two UWB-MIMO antennas with high isolation using sleeve coupled stepped impedance resonators," *2012 IEEE Asia-Pacific Conference on Antennas and Propagation*, 21–22, Aug. 2012.
23. Wu, Y. and Q. Chu, "Dual-band multiple input multiple output antenna with slitted ground," *IET Microwaves, Antennas Propagation*, Vol. 8, No. 13, 1007–1013, Oct. 2014.
24. Amin, F., R. Saleem, T. Shabbir, S. U. Rehman, M. Bilal, and M. F. Shafique, "A compact quad-element UWB-MIMO antenna system with parasitic decoupling mechanism," *Applied Sciences*, Vol. 9, No. 11, 2019. [Online]. Available: <https://www.mdpi.com/2076-3417/9/11/2371>.
25. Kumar, S., R. Kumar, R. K. Vishwakarma, and K. Srivastava, "An improved compact MIMO antenna for wireless applications with bandnotched characteristics," *AEU-International Journal of Electronics and Communications*, Vol. 90, 20–29, 2018. [Online]. Available: <http://www.sciencedirect.com/science/article/pii/S1434841118305168>.
26. Yang, Z. and H. Cui, "A compact MIMO antenna with inverted C-shaped ground branches for mobile terminals," *International Journal of Antennas and Propagation*, Vol. 2016, 1–6, 2016.

27. Dkiouak, A., A. Zakriti, M. El Quahabi, A. Zugari, and M. Khalladi, "Design of a compact MIMO antenna for wireless applications," *Progress In Electromagnetics Research M*, Vol. 72, 115–124, 2018.
28. Anuvind, R., S. D. Joseph, and A. Kothari, " 2×2 MIMO antenna at 2.4 GHz for WLAN applications," *2015 International Conference on Microwave, Optical and Communication Engineering (ICMOCE)*, 80–83, Dec. 2015.
29. Malviya, L., R. K. Panigrahi, and M. V. Kartikeyan, " 2×2 MIMO antenna for ISM band application," *2016 11th International Conference on Industrial and Information System (ICIIS)*, 794–797, 2016.
30. Payandehjoo, K. and R. Abhari, "Isolation enhancement between tightly spaced compact unidirectional patch-antennas on multilayer EBG surfaces," *International Journal of RF and Microwave Computer-Aided Engineering*, Vol. 25, No. 1, 30–38, 2015.
31. Li, Z., Z. Du, M. Takahashi, K. Saito, and K. Ito, "Reducing mutual coupling of MIMO antennas with parasitic elements for mobile terminals," *IEEE Transactions on Antennas and Propagation*, Vol. 60, No. 2, 473–481, Feb. 2012.
32. Payandehjoo, K. and R. Abhari, "Investigation of parasitic elements for coupling reduction in multiantenna hand-set devices," *International Journal of RF and Microwave Computer-Aided Engineering*, Vol. 24, No. 1, 1–10, 2014.
33. Ayatollahi, M., Q. Rao, and D. Wang, "A compact, high isolation and wide bandwidth antenna array for long term evolution wireless devices," *IEEE Transactions on Antennas and Propagation*, Vol. 60, No. 10, 4960–4963, Oct. 2012.
34. Jeong, G.-T., S. Choi, K. Hak, and W. S. Kim, "Low-profile dual wideband MIMO antenna with low ECC for LTE and Wi-Fi applications," *International Journal of Antennas and Propagation*, Vol. 2014, 6 pages, May 2014.
35. Vaughan, R. G. and J. B. Andersen, "Antenna diversity in mobile communications," *IEEE Transactions on Vehicular Technology*, Vol. 36, No. 4, 149–172, Nov. 1987.
36. Taga, T., "Analysis for mean effective gain of mobile antennas in land mobile radio environments," *IEEE Transactions on Vehicular Technology*, Vol. 39, No. 2, 117–131, May 1990.